

Cub Cadet®

OPERATOR'S MANUAL

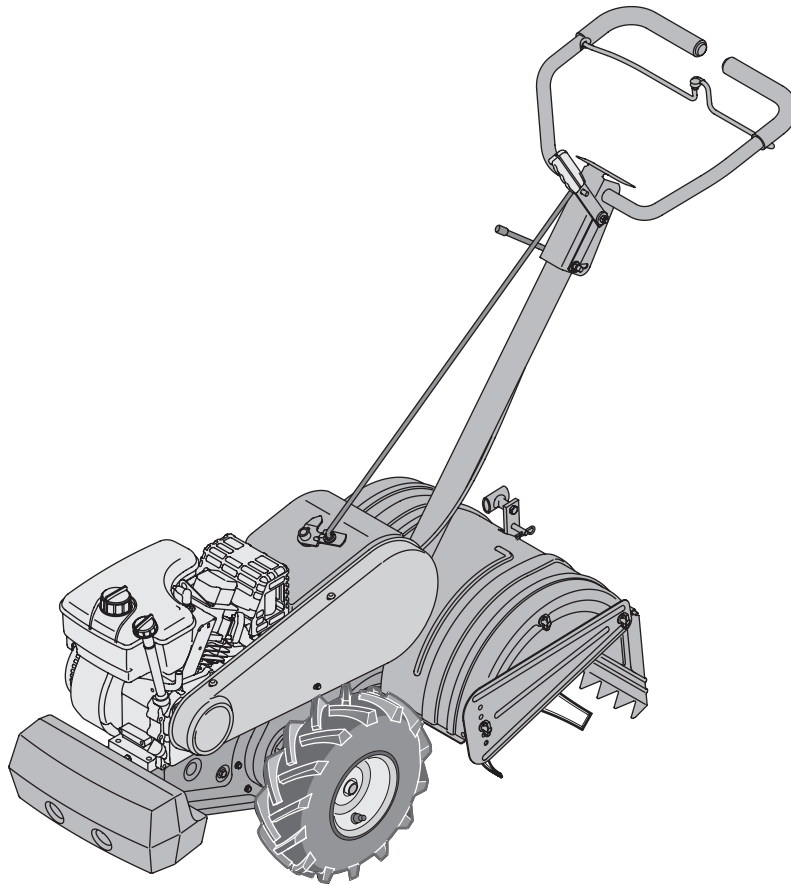

Rear Tine Tiller – Model RT 65

IMPORTANT

READ SAFETY RULES AND INSTRUCTIONS CAREFULLY BEFORE OPERATION

Warning: This unit is equipped with an internal combustion engine and should not be used on or near any unimproved forest-covered, brush-covered or grass-covered land unless the engine's exhaust system is equipped with a spark arrester meeting applicable local or state laws (if any). If a spark arrester is used, it should be maintained in effective working order by the operator. In the State of California the above is required by law (Section 4442 of the California Public Resources Code). Other states may have similar laws. Federal laws apply on federal lands. A spark arrester for the muffler is available through your nearest engine authorized service dealer or contact the service department, P.O. Box 361131 Cleveland, Ohio 44136-0019.

This Operator's Manual is an important part of your new tiller. It will help you assemble, prepare, and maintain the unit for best performance. Please read and understand what it says.

Table of Contents

Safe Operation Practices	4	Maintaining Your Tiller	12
Assembling Your Tiller.....	6	Troubleshooting.....	13
Know Your Tiller	8	Parts Lists	14
Operating Your Tiller	10	Warranty	Back Cover
Making Adjustments	11		

Finding and Recording Model Number

BEFORE YOU BEGIN ASSEMBLING YOUR NEW EQUIPMENT, please locate the model plate on the equipment and copy the information to the sample model plate provided to the right. You can locate the model plate by looking at the rear of the tine shield. This information is important for use when communicating with an authorized service dealer.

Model Number	Serial Number
<i>Cub Cadet</i>	CUB CADET LLC
www.cubcadet.com	P. O. BOX 361131
DEALER LOCATOR PHONE NUMBER: 877-282-8684	CLEVELAND, OH 44136

Customer Support

If you have difficulty assembling this product or have any questions regarding the controls, operation, or maintenance of this unit, you can seek help from the experts. Choose from the options below:

1. Visit **cubcadet.com**. Click on the Service & Support menu option.
2. Phone call our Dealer Locator Number at 1 (877) 282-8684.
3. The **engine manufacturer** is responsible for all engine-related issues with regards to performance, power-rating, specifications, warranty and service. Please refer to the engine manufacturer's Owner's/Operator's Manual, packed separately with your unit, for more information.

The screenshot shows the Cub Cadet website interface. At the top left is the Cub Cadet logo with the tagline "THE SCIENCE OF COMMON SENSE." To the right are links for "site map" and "customer service". Below the logo is a navigation bar with links: "HOME | ABOUT US | STORE LOCATOR | CUB CADET DIFFERENCE | FINANCING | YARD TIPS". A secondary navigation bar contains "Answers" (highlighted with a mouse cursor), "My Stuff", "Login", and "Help". The main content area features a "Products & Services" dropdown menu set to "All Products", a "Search Text (optional)" input field, and a "Search" button. Below the search field is a "Search by" dropdown menu set to "Similar Phrases". A "Powered by Rightflow" logo is in the bottom right corner.

1

Safety Labels



WARNING

This symbol points out important safety instructions which, if not followed, could endanger the personal safety and/or property of yourself and others. Read and follow all instructions in this manual before attempting to operate this machine. Failure to comply with these instructions may result in personal injury. When you see this symbol.

HEED ITS WARNING!

Your Responsibility

Restrict the use of this power machine to persons who read, understand and follow the warnings and instructions in this manual and on the machine.

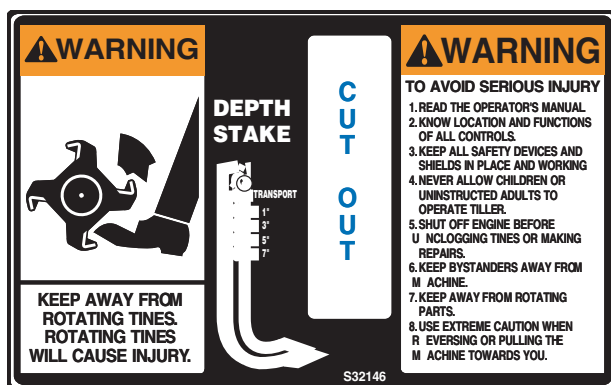

2

Safe Operation Practices



WARNING

This symbol points out important safety instructions which, if not followed, could endanger the personal safety and/or property of yourself and others. Read and follow all instructions in this manual before attempting to operate this machine. Failure to comply with these instructions may result in personal injury. When you see this symbol, HEED ITS WARNING!



WARNING: Engine Exhaust, some of its constituents, and certain vehicle components contain or emit chemicals known to State of California to cause cancer and birth defects or other reproductive harm.

DANGER: This machine was built to be operated according to the rules for safe operation in this manual. As with any type of power equipment, carelessness or error on the part of the operator can result in serious injury. This machine is capable of amputating hands and feet and throwing objects. Failure to observe the following safety instructions could result in serious injury or death.

Training

- Read, understand, and follow all instructions on the machine and in the manual(s) before attempting to assemble and operate. Keep this manual in a safe place for future and regular reference and for ordering replacement parts.
- Be familiar with all controls and their proper operation. Know how to stop the machine.
- Never allow children under 14 years old to operate this machine. Children 14 years old and over should read and understand the operation instructions and safety rules in this manual and should be trained and supervised by a parent.
- Never allow adults to operate this machine without proper instruction.
- Keep bystanders, helpers, pets, and children at least 75 feet from the machine while it is in operation. Stop machine if anyone enters the area.

Preparation

- Thoroughly inspect the area where the equipment is to be used. Remove all stones, sticks, wire, and other foreign objects which could be tripped over and cause personal injury.
- Wear sturdy, rough-soled work shoes and close fitting slacks and shirt. Loose fitting clothes or jewelry can be caught in movable parts. Never operate this machine in bare feet or sandals.
- Disengage clutch levers and shift (if provided) into neutral ("N") before starting the engine.
- Never leave this machine unattended with the engine running.
- Never attempt to make any adjustments while engine is running, except where specifically recommended in the operator's manual.
- To avoid personal injury or property damage use extreme care in handling gasoline. Gasoline is extremely flammable and the vapors are explosive. Serious personal injury can occur when gasoline is spilled on yourself or your clothes which can ignite. Wash your skin and change clothes immediately.
- Use only an approved gasoline container.
- Extinguish all cigarettes, cigars, pipes and other sources of ignition.
- Never fuel machine indoors.

- Never remove gas cap or add fuel while the engine is hot or running.
- Allow engine to cool at least two minutes before refueling
- Never over fill fuel tank. Fill tank to no more than 1/2 inch below bottom of filler neck to provide space for fuel expansion.
- Replace gasoline cap and tighten securely.
- If gasoline is spilled, wipe it off the engine and equipment. Move machine to another area. Wait five minutes before starting the engine.
- Never store the machine or fuel container inside near an open flame, spark or pilot light (e.g. furnace, water or space heater, clothes dryer, etc.).
- Allow machine to cool five minutes before storing.

Operation

- Do not put hands or feet near rotating parts. Contact with the rotating parts can amputate hands and feet.
- Do not operate machine while under the influence of alcohol or drugs.
- Never operate this machine without good visibility or light. Always be sure of your footing and keep a firm hold on the handles.
- Keep bystanders, helpers, pets, and children at least 75 feet from the machine while it is in operation. Stop the machine if anyone enters the area.
- Be careful when tilling in hard ground. The tines may catch in the ground and propel the tiller forward. If this occurs, let go of the handle bars and do not restrain the machine.
- Exercise extreme caution when operating on or crossing gravel surfaces. Stay alert for hidden hazards or traffic.
- Never operate the machine at high transport speeds on hard or slippery surfaces.
- Exercise caution to avoid slipping or falling.
- Look down and behind and use care when in reverse or pulling machine towards you.
- Start the engine according to the instructions found in this manual and keep feet well away from the tines at all times.

- After striking a foreign object, stop the engine, disconnect the spark plug wire and ground against the engine. Thoroughly inspect the machine for any damage. Repair the damage before starting and operating.
- Disengage all clutch levers (if fitted) and stop engine before you leave the operating position (behind the handles). Wait until the tines come to a complete stop before unclogging the tines, making any adjustments, or inspections.
- Never run an engine indoors or in a poorly ventilated area. Engine exhaust contains carbon monoxide, an odorless and deadly gas.
- Muffler and engine become hot and can cause a burn. Do not touch.
- Use caution when tilling near fences, buildings and underground utilities. Rotating tines can cause property damage or personal injury.
- Do not overload machine capacity by attempting to till soil too deep at too fast of a rate.
- If the machine should start making an unusual noise or vibration, stop the engine, disconnect the spark plug wire and ground it against the engine. Inspect thoroughly for damage. Repair any damage before starting and operating.
- Keep all shields, guards, and safety devices in place and operating properly.
- Never pick up or carry machine while the engine is running.
- Use only attachments and accessories approved by the manufacturer. Failure to do so can result in personal injury.
- If situations occur which are not covered in this manual, use care and good judgment. Contact your dealer or call the customer service number found on page two.

Maintenance & Storage

- Never tamper with safety devices. Check their proper operation regularly.
- Check bolts and screws for proper tightness at frequent intervals to keep the machine in safe working condition. Also, visually inspect machine for any damage.
- Before cleaning, repairing, or inspecting, stop the engine and make certain the tines and all moving parts have stopped. Disconnect the spark plug wire and ground it against the engine to prevent unintended starting.
- Do not change the engine governor settings or over-speed the engine. The governor controls the maximum safe operating speed of the engine.
- Maintain or replace safety and instruction labels, as necessary.
- Follow this manual for safe loading, unloading, transporting, and storage of this machine.
- Never store the machine or fuel container inside where there is an open flame, spark or pilot light such as a water heater, furnace, clothes dryer, etc.
- Always refer to the operator's manual for proper instructions on off-season storage.
- If the fuel tank has to be drained, do this outdoors.
- Observe proper disposal laws and regulations for gas, oil, etc. to protect the environment.

Your Responsibility

- Restrict the use of this power machine to persons who read, understand, and follow the warnings and instructions in this manual and on the machine.
- The safety labels on the tiller are shown in the "Safety Labels" section. To ensure safe operation of the tiller, follow the instructions on all labels closely.

2

Safe Operation Practices



WARNING

This symbol points out important safety instructions which, if not followed, could endanger the personal safety and/or property of yourself and others. Read and follow all instructions in this manual before attempting to operate this machine. Failure to comply with these instructions may result in personal injury. When you see this symbol, HEED ITS WARNING!

3

Assembling Your Tiller



WARNING

Disconnect the spark plug wire and ground it against the engine to prevent unintended starting.

Be certain to check the clutch cable adjustment before operating the tiller.

NOTE: References to right or left side of the tiller are determined from behind the unit in the operating position.

To Remove Unit From Carton

- Remove staples, break glue on top flaps, or cut tape at carton end and peel along top flap to open carton.
- Remove loose parts included with unit (i.e., operator's manual, etc.).
- Cut corners and lay carton down flat.
- Remove packing material.
- Roll or slide unit out of carton. Check carton thoroughly for loose parts.
- Extend control cable and lay on the floor. Be careful not to bend or kink control cable.

IMPORTANT: This unit is shipped without gasoline or oil in the engine. Be certain to service engine with gasoline and oil as instructed in the separate engine manual before operating your machine.

Loose Parts In Carton

- Depth Stake
- Handle Assembly
- Shift Rod

NOTE: All hardware needed for assembly is attached to the loose parts or the tiller.

Before Assembly



WARNING: Disconnect the spark plug wire and ground it against the engine to prevent unintended starting.

Attaching Depth Stake

- Tip the tiller forward so it rests on front counterweight.
- Unthread the "T" knob from the top of the depth stake and remove the flat washer and hex bolt. Remove the hairpin clip from the clevis pin. See Figure 3-1.
- Raise the tine shield hinge flap assembly and insert the depth stake assembly in the slot (under the tine shield) and up through the tine shield assembly.
- Insert clevis pin through the tine shield and depth stake assemblies. Secure with hairpin clip.
- Insert a hex bolt into top hole of the depth stake assembly. Place flat washer on the hex bolt and thread "T" knob onto the hex bolt. Tighten securely. See Figure 3-1.
- Tip the tiller back down so it rests on the tines.

Attaching Handle Assembly

- Remove top two bolts and flange lock nuts from handle mounting brackets, but do not remove the bottom bolt and nut. See Figure 3-2.
- Place handle assembly in position between the handle mounting brackets.
- Line up holes in handle with holes in bracket and secure with hardware previously removed.

Attaching Clutch Cable

Attach the clutch cable to the handle as follows: (be careful not to kink the cable)

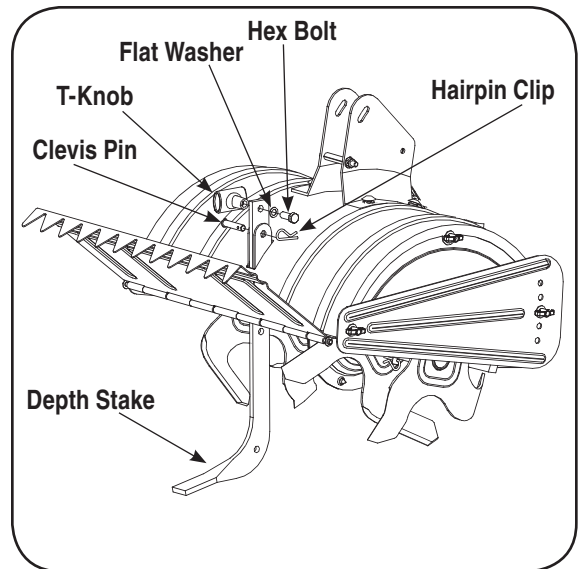

Figure 3-1

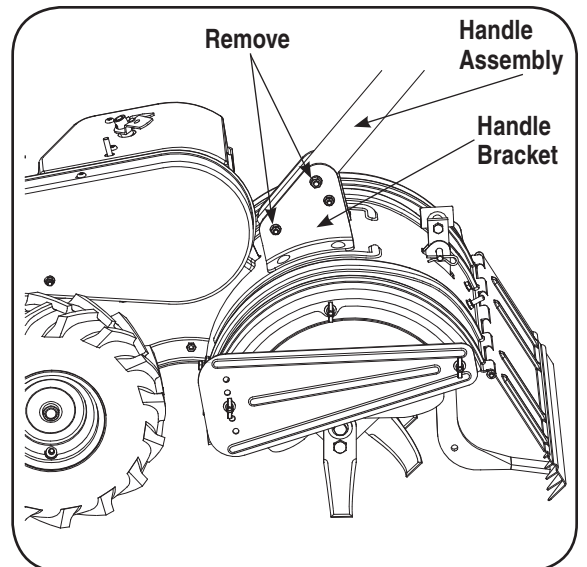

Figure 3-2

- Remove threaded eyebolt and nut from the cable end.
- Route the clutch cable to the right side of the handle mounting brackets and underneath the handle.
- Push the cable through the hole in the center of the handle and snap in the plastic fitting. See Figure 3-3.
- Remove slot head screw, nut, and two flat washers from the clutch bail. See Figure 3-4.
- Fasten the threaded eyebolt onto bail by securing from top with slot head screw, flat washers and lock nut.
- Thread eyebolt and nut removed earlier into the internally threaded tube at the end of the cable. Thread engagement should be about 3/4". Tighten nut against tube at end of cable. See Figure 3-4.

NOTE: Do not overtighten clutch cable. Too much tension may cause it to break.



WARNING: Be certain to check the clutch cable adjustment before operating the tiller.

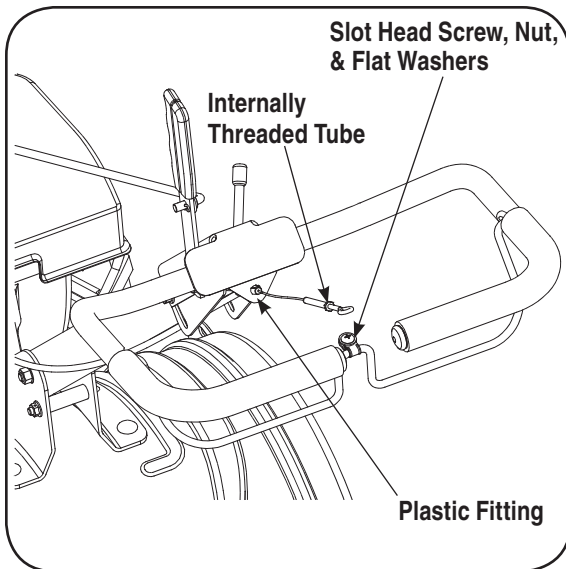

Figure 3-3

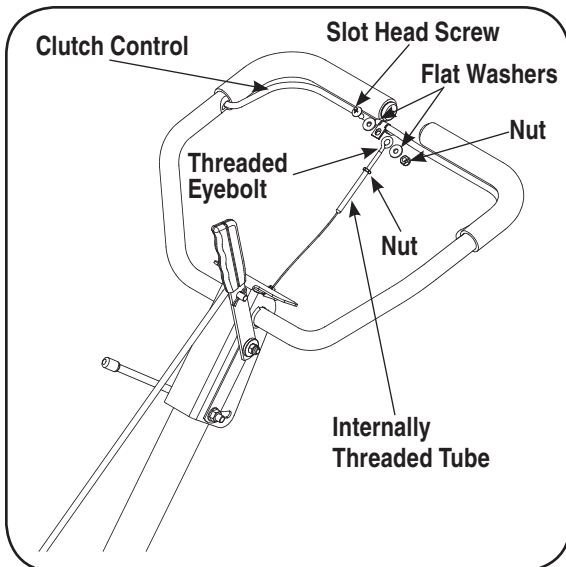

Figure 3-4

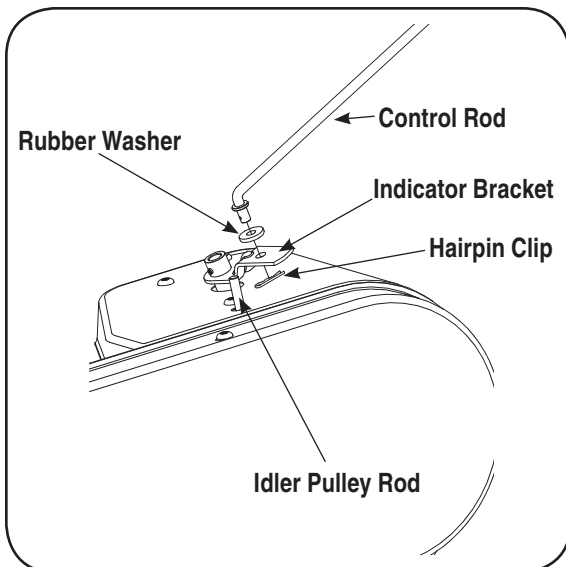

Figure 3-5

Attaching Control Rod

- Make sure the handle assembly is in the highest position. Refer to Know Your Tiller section.
- Remove hairpin clips from control rod, (rubber washers to remain on control rod).
- Insert the shorter, (angled), end of the control rod through the indicator bracket on the shift cover and secure with hairpin clip that was previously removed. See Figure 3-5.
- Insert the longer end of the control rod through the hole in the gear selector handle and secure with hairpin clip. See Figure 3-6.

Final Clutch Adjustment

IMPORTANT: Service the engine with oil and gasoline before checking this adjustment. Refer to the separate engine manual packed with your tiller for proper fuel and engine oil recommendations.

Position the tiller so the front counterweight is against a solid object, such as a wall. With the gear selection lever in NEUTRAL, start the engine. Refer to the separate engine manual.

Standing on the right side of the tiller, examine the belt (inside the belt cover). It should not be turning.



WARNING: Do not put your fingers under the belt cover.

If the belt turns without bail engaged, adjust by unthreading the internally threaded tube at the end of the cable a few turns clockwise (when standing in operator's position) and then retighten the nut against the tube.

Now move the shift lever to FORWARD position. Carefully engage the clutch by lifting the clutch control bail against the handle. The wheels should spin.

If the wheels do not spin with the unit in forward, adjust by unthreading the tube at the end of the cable a few turns counter-clockwise (when standing in operator's position) and then retighten the nut against the tube.

Recheck both adjustments, and readjust as necessary.

NOTE: A secondary cable adjustment is available if you reach the point that additional adjustment is needed. Remove the belt cover and move the hex nuts at the other end of the cable towards the end of the casing. Then readjust the hex nuts at the handle.

Tire Pressure

The tires on your unit may be over-inflated for shipping purposes. Reduce the tire pressure before operating the unit. Recommended operating tire pressure is approximately 20 p.s.i. (check sidewall of tire for tire manufacturer's recommended pressure).



WARNING: Maximum tire pressure under any circumstances is 30 p.s.i. Equal tire pressure should be maintained on both tires.

3

Assembling Your Tiller



WARNING

Do not put your fingers under the belt cover.

Maximum tire pressure under any circumstances is 30 p.s.i. Equal tire pressure should be maintained on both tires.

4

Know Your Tiller



WARNING

Make certain unit is in **NEUTRAL** when starting the engine.

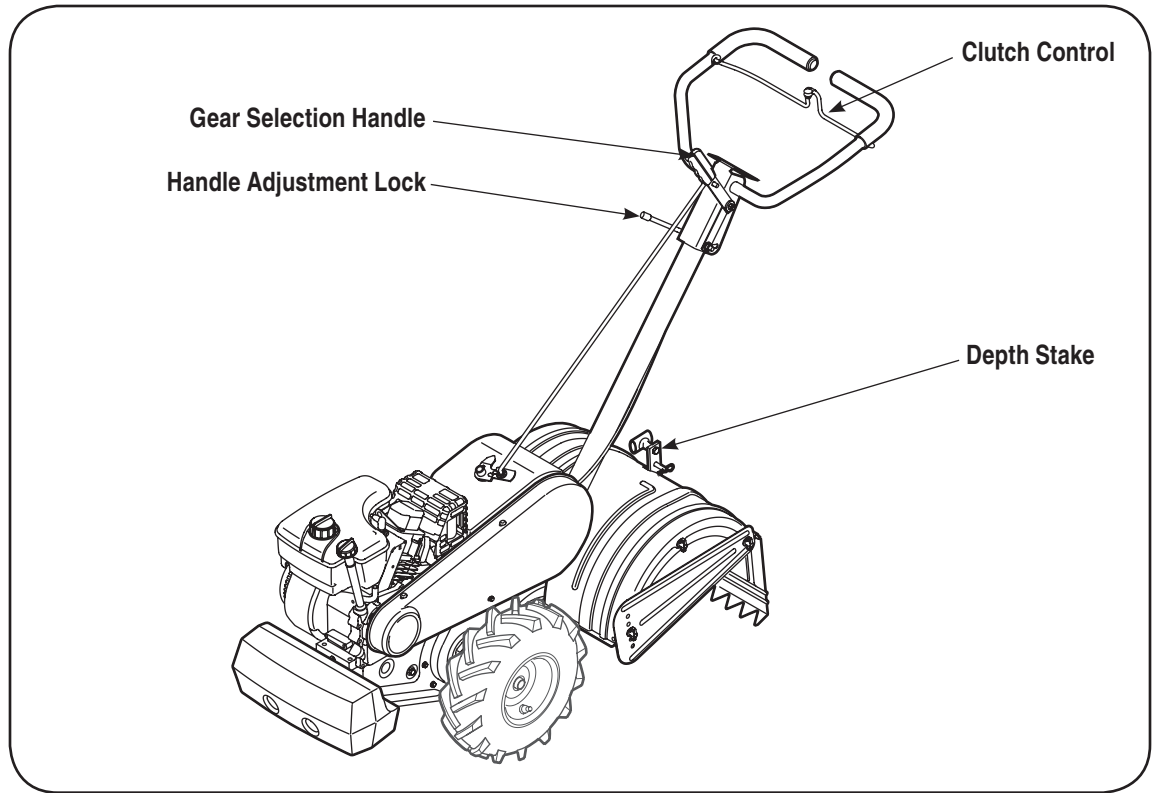

Figure 4-1

Gear Selection Handle

The gear selection handle is located in the center of the handle on the tiller. It is used to select **NEUTRAL**, **REVERSE**, or one of the **FORWARD** mode. Pull or push the handle so that the indicator on top of shift cover points to the operating mode desired.

See Figure 4-1.

Neutral

Transmission is in neutral.

Reverse

Reverse wheel drive.

Forward Modes

Wheels Forward: Forward wheel drive only.

Tines Reverse: Forward wheel drive and reverse tine drive.

Tines Forward: Forward wheel and tine drive.

IMPORTANT: Use the reverse tine drive when tilling virgin ground, sod, or hard soil. Use the forward tine drive when cultivating or tilling soft ground.

NOTE: If difficulty is encountered in moving the gear selection handle, refer to following helpful hints. To shift into forward or reverse wheel drive, move tiller forward slightly then backward to allow the gears to synchronize.

To shift into forward wheels and tine drive, push forward slightly on the gear selection handle and slowly engage the clutch control allowing the gears to synchronize. To stop forward movement and tine drive, release the clutch control. Do not shift gears with the clutch control engaged except when engaging the tines.



WARNING: Make certain unit is in **NEUTRAL** when starting the engine.

Clutch Control

The clutch control is located beneath the handle. Squeezing the clutch control against the handle engages the wheel and tine drive mechanisms.

NOTE: Never engage clutch lever while shifting.

Handle Adjustment Lock

The handle may be adjusted to the height desired. Loosen the handle height adjustment lock a few turns. Pivot handle up or down to desired position. Tighten lock.

Throttle Control

The throttle control lever is located on the engine. It controls the engine speed and stops the engine.

Choke Lever (If Equipped)

The choke lever is located by the throttle. It is used to enrich the fuel mixture in the carburetor when starting a cold engine.

Primer Button (If Equipped)

The primer button is located behind the air cleaner. It is used to enrich the fuel mixture in the carburetor when starting a cold engine.

Depth Stake

The depth stake controls the tilling depth. Refer to "Setting the Depth" in the Operating Section.

Engine Controls

See the separate engine manual for additional information and functions of the engine controls.

4

Know Your Tiller



WARNING

This symbol points out important safety instructions which, if not followed, could endanger the personal safety and/or property of yourself and others. Read and follow all instructions in this manual before attempting to operate this machine. Failure to comply with these instructions may result in personal injury. When you see this symbol, **HEED ITS WARNING!**

5

Operating Your Tiller



WARNING

Read, understand, and follow all instructions and warnings on the machine and in this manual before operating.

Use extreme care when handling gasoline. Gasoline is extremely flammable and the vapors are explosive. Never fuel machine indoors or while the engine is hot or running.

Be sure no one is standing in front of the tiller while the engine is running or being started.

Be certain spark plug wire is disconnected and grounded against the engine when performing any adjustments.



WARNING: Read, understand, and follow all instructions and warnings on the machine and in this manual before operating.

Before Starting

Gas And Oil Fill-Up

Service the engine with gasoline and oil as instructed in the separate engine manual packed with your tiller. Read instructions carefully.



WARNING: Use extreme care when handling gasoline. Gasoline is extremely flammable and the vapors are explosive. Never fuel machine indoors or while the engine is hot or running.

Starting Engine

NOTE: When pushing the unit with the engine off, you will hear a ratcheting sound (gear noise) which is normal.



WARNING: Be sure no one is standing in front of the tiller while the engine is running or being started.

- Place gear selection lever in NEUTRAL.
- Place the throttle control lever in FAST position or if equipped, place the engine speed control in the START position.
- Move choke lever to CHOKE position or if equipped, push primer two (2) or three (3) times. Wait about two (2) seconds between each push.

NOTE: A warm engine may not require choking or priming.

- Stand at side of tiller. Grasp the starter handle and pull out slowly, until it pulls slightly harder. Let rope rewind slowly.
- Pull starter handle rapidly. Do not allow handle to snap back. Allow it to rewind slowly while keeping a firm hold on the starter handle.
- Repeat previous steps until engine starts.
- As engine warms up and begins to operate evenly, move choke lever gradually to RUN position. If engine falters, return to choke position, then slowly move to RUN position.
- Refer to engine manual for additional engine information.

NOTE: After starting and prior to using the tiller for the first time, be certain to check the clutch adjustment as described in "Checking the Clutch Adjustment" section of the Assembly Instructions.

To Stop Engine

- Move throttle control to STOP or OFF position.
- Disconnect spark plug wire and ground to prevent accidentally starting while equipment is unattended.

NOTE: After the first ten hours of operation, recheck the clutch adjustment. Refer to final clutch adjustment in Assembly Instructions.

Setting The Depth

Tilling depth is controlled by the depth stake which can be adjusted to five different settings. Adjust the side shields as you adjust the depth stake.



WARNING: Be certain spark plug wire is disconnected and grounded against the engine when performing any adjustments.

- When using the tiller for the first time, use the second adjustment hole from the top (1" of tilling depth). See Figure 5-1.

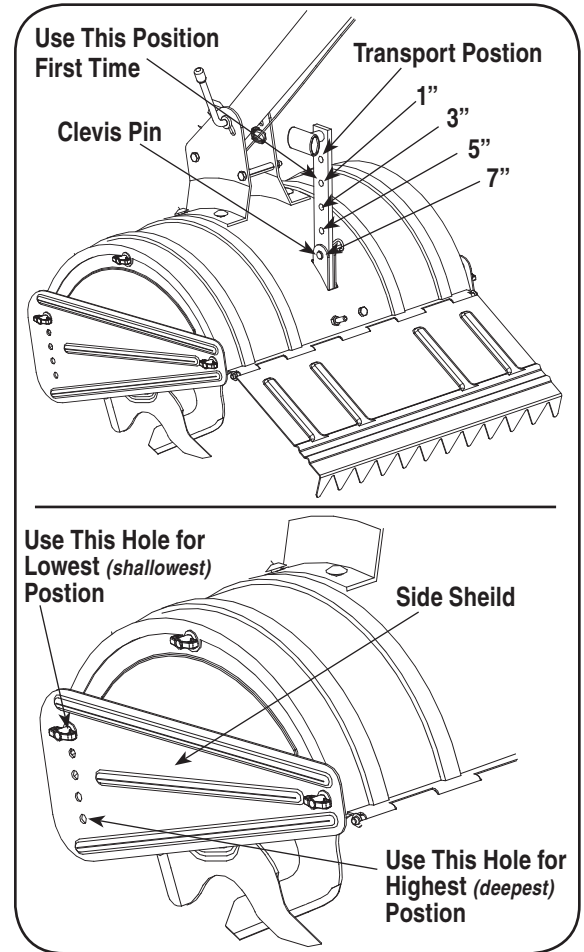

Figure 5-1

- When breaking up sod and for shallow cultivation, use the setting which gives 1" of tilling depth (second hole from the top). Place the side shields in their lowest position.
- For further depth, raise the depth stake and side shields and also make one or two more passes over the area.
- When tilling loose soil, the depth stake may be raised to its highest position (use bottom adjustment hole) to give the deepest tilling depth. Raise the side shields to their highest position.
- To transport tiller, lower the depth stake (use top adjustment hole).

To adjust the depth stake, remove the clevis pin and hairpin clip. Move the depth stake to the desired setting and secure with the clevis pin and hairpin clip. See Figure 7.

To adjust the side shields, remove the wing nuts. Move the side shield to the desired position and replace the wing nuts. Tighten securely.

Operating the Tiller

- Select the depth stake setting.
- Start engine as instructed on the previous page.
- Move gear selection handle to one of the forward modes or reverse.



WARNING: Do not move the gear selection handle with the wheels or tines engaged. Make certain the unit is stopped completely before changing the gear selection. A partial engagement may be necessary when engaging tines.

IMPORTANT: Use the reverse tine drive when tilling virgin ground, sod, or hard soil. Use the forward tine drive when cultivating or tilling soft ground.

- Squeeze the clutch handle against the handle to engage the wheels and tines.

NOTE: Make certain the gear selection indicator is correctly positioned before engaging the clutch handle. If it is between gears, the engine will stall.

To transport tiller, **do not** engage the tines. Select the wheel drive only.



WARNING: Do not push down on the handles so that the wheels are lifted off the ground while using the tine drive, or the tiller could move backward and cause personal injury.

For best results, it is recommended the garden be tilled twice (lengthwise, then width-wise) to pulverize the soil.

Making Adjustments



WARNING: Never attempt to make any adjustments while the engine is running, except where specified in operator's manual.

Handle Adjustment

The handle height may be adjusted to the desired height. Refer to the handle adjustment in Know Your Tiller section.

Belt Tension Adjustment

Periodic adjustment of the belt tension may be required due to normal stretch and wear on the belt. Adjustment is needed if the tines or wheels seem to hesitate while turning, but the engine maintains the same speed.

To adjust the tension on the belt, refer to Final Clutch Adjustment in Assembly Instructions.

After belt tension has been adjusted, if the belt is excessively stretched, you may need to adjust the idler pulley rod. This can easily be checked.

With the engine off and the clutch control bail disengaged, shift the gear selection handle to each forward mode. If the indicator bracket touches the idler pulley rod (with the clutch control bail disengaged), then an adjustment is necessary.

- Disconnect and ground out spark plug wire against the engine.
- Remove the belt cover as described under Belt Replacement in the Maintenance section.
- Remove the hairpin clip and spring washer from the idler pulley rod. Refer to Figure 9.
- Move the idler pulley rod to the lower hole in the idler bracket.
- Replace the spring washer and hairpin clip.
- Check clearance of the idler pulley rod to the indicator bracket by shifting to each forward mode, as before.

Engine Adjustment

Refer to the separate engine manual for engine adjustment instructions.

6

Making Adjustments



WARNING

Do not move the gear selection handle with the wheels or tines engaged. Make certain the unit is stopped completely before changing the gear selection. A partial engagement may be necessary when engaging tines.

Do not push down on the handles so that the wheels are lifted off the ground while using the tine drive, or the tiller could move backward and cause personal injury.

Never attempt to make any adjustments while the engine is running, except where specified in operator's manual.

7

Maintaining Your Tiller



WARNING

Disconnect the spark plug wire and ground it against the engine before performing any repairs or maintenance.



WARNING: Disconnect the spark plug wire and ground it against the engine before performing any repairs.

Engine

Refer to the separate engine manual for engine maintenance instructions.

Maintain **engine oil** as instructed in the separate engine manual packed with your unit. Read and follow instructions carefully.

Service **air cleaner** every ten hours under normal conditions. Clean every hour under extremely dusty conditions. Poor engine performance and flooding usually indicates that the air cleaner should be serviced. To service the air cleaner, refer to the separate engine manual packed with your unit.

IMPORTANT: Never run your engine without air cleaner completely assembled.

The **spark plug** should be cleaned and the gap reset every 25 hours of engine operation. Spark plug replacement is recommended at the start of each tiller season; check engine manual for correct plug type and gap specification.

Clean the engine regularly with a cloth or brush. Keep the cooling system (blower housing area) clean to permit proper air circulation which is essential to engine performance and life. Be certain to remove all dirt and combustible debris from muffler area.

Lubrication

Transmission

The transmission is pre-lubricated and sealed at the factory. It requires no checking unless the transmission is disassembled. To fill with grease, lay the right half of the transmission on its side, add 22 ounces of Benalene 920 grease, and assemble the left half to it. This grease can be obtained at your nearest authorized dealer by ordering part number 737-0300.

Clutch Handle

Lubricate the pivot point on the clutch handle and the cable at least once a season with light oil. The control must operate freely in both directions.

Pivot Points

Lubricate all pivot points and linkages at least once a season with light oil.

Tine Shafts

Remove tine assemblies and lubricate the tine shafts at least once a season.

Wheel Shafts

Remove wheel assemblies and lubricate the axle shafts at least once a season.

Cleaning Tine Area

Clean the underside of the tine shield after each use. The dirt washes off the tines easier if rinsed off immediately instead of after it dries. Always towel dry the tiller afterwards and apply a light coat of oil or silicone to prevent rusting or water damage.

IMPORTANT: Never use a "pressure washer" to clean your tiller. Water can penetrate tight areas of the tiller and its chain case and cause serious damage to the unit.

Belt Replacement

Your tiller has been engineered with a belt made of special material (Kevlar Tensile) for longer life and better performance. It should not be replaced with an off-the-shelf belt. Order all belts through your authorized service dealer.

- Disconnect and ground the spark plug wire against the engine.
- Remove the belt cover from the left side of the tiller by remove two torx screws from the top of belt cover. See Figure 7-1.
- Remove the hex cap nut and flat washer from the side

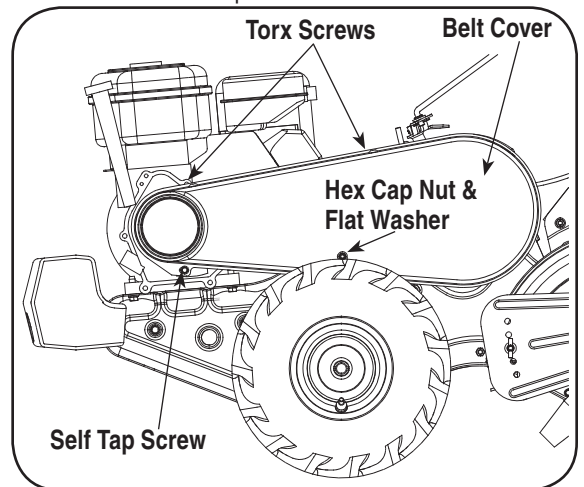

Figure 7-1

of the belt cover and remove the self tap screw at the bottom of the front of the cover.

- Remove the belt keeper bracket located behind the engine pulley by removing two hex bolts and lock washers. See Figure 7-2.
- Remove belt and reassemble new belt. Follow instructions in reverse order.

NOTE: Upon reassembly, make certain the belt is routed over the idler pulley and inside of belt keepers by engine pulley. See Figure 7-2.

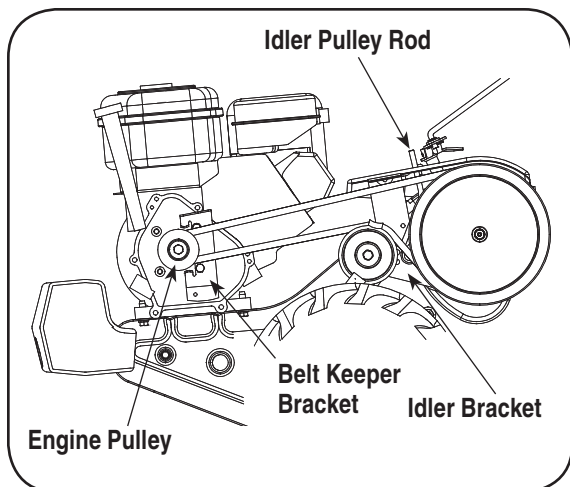

Figure 7-2
Off-Season Storage

If the tiller will not be used for a period longer than 30 days, the following steps should be taken to prepare the tiller for storage.

- Clean the exterior of engine and the entire tiller thoroughly. Lubricate the tiller as described in the lubrication instructions.
- We do not recommend the use of pressure washers to clean your unit. They may cause damage to electric components, spindles, pulleys, bearings or the engine. The use of pressure washers will result in shortened life and reduce serviceability.
- Refer to the engine manual for correct engine storage instructions.
- Wipe tines with oiled rag to prevent rust.
- Store tiller in a clean, dry area. Do not store next to corrosive materials, such as fertilizer.

NOTE: When storing any type of power equipment in an unventilated or metal storage shed, care should be taken to rustproof the equipment. Using a light oil or silicone, coat the equipment and especially any springs, bearings, and cables.

Trouble	Possible Cause(s)	Corrective Action
Engine fails to start	Fuel tank empty, or stale fuel. Throttle control lever not in correct starting position (if so equipped). Blocked fuel line. Dirty air cleaner. Choke not in ON position. Spark plug wire disconnected. Faulty spark plug. Engine flooded.	Fill tank with clean, fresh gasoline. Fuel will not last over thirty days unless a fuel stabilizer is used. Move throttle lever to start position. Clean fuel line. Refer to the engine manual packed with your unit. Move switch to ON position. Connect wire to spark plug. Clean, adjust gap or replace. Refer to the engine manual packed with your unit.
Engine runs erratic	Unit running on CHOKE. Spark plug wire loose. Blocked fuel line or stale fuel. Vent in gas cap plugged. Water or dirt in fuel system. Dirty air cleaner. Carburetor out of adjustment.	Move choke lever to OFF position. Connect and tighten spark plug wire. Clean fuel line; fill tank with clean, fresh gasoline. Fuel will not last over thirty days unless a fuel stabilizer is used. Clear vent. Drain fuel tank. Refill with fresh fuel. Refer to the engine manual packed with your unit. Refer to the engine manual packed with your unit.
Engine overheats	Engine oil level low. Dirty air cleaner. Air flow restricted. Carburetor not adjusted properly.	Fill crankcase with proper oil. Refer to the engine manual packed with your unit. Refer to the engine manual packed with your unit. Adjust carburetor as instructed in separate engine manual.
Tines do not engage	Foreign object lodged in tines. Tine clevis pin(s) missing. Pulley and idler not in correct adjustment. Not shifting properly. Control cable not adjusted properly. Belt worn and/or stretched.	Dislodge foreign object. Replace tine clevis pin(s). Take unit to authorized service dealer. Refer to Controls section of operator's manual for proper shifting procedures. Adjust control cable (see assembly instructions). Replace belt.
Tines skip over ground	Improper rotation.	Forward rotation should only be used on soil that has already been tilled, not on virgin soil.
Wheels do not engage	Clevis pin missing. Tiller is not being shifted properly. Control cable not adjusted properly. Belt worn and/or stretched.	Replace clevis pin. Refer to Controls section of operator's manual for proper shifting procedures. Adjust control cable (see assembly instructions). Replace belt.

8

Trouble Shooting Guide



WARNING

Do not move the gear selection handle with the wheels or tines engaged. Make certain the unit is stopped completely before changing the gear selection. A partial engagement may be necessary when engaging tines.

Do not push down on the handles so that the wheels are lifted off the ground while using the tine drive, or the tiller could move backward and cause personal injury.

Never attempt to make any adjustments while the engine is running, except where specified in operator's manual.

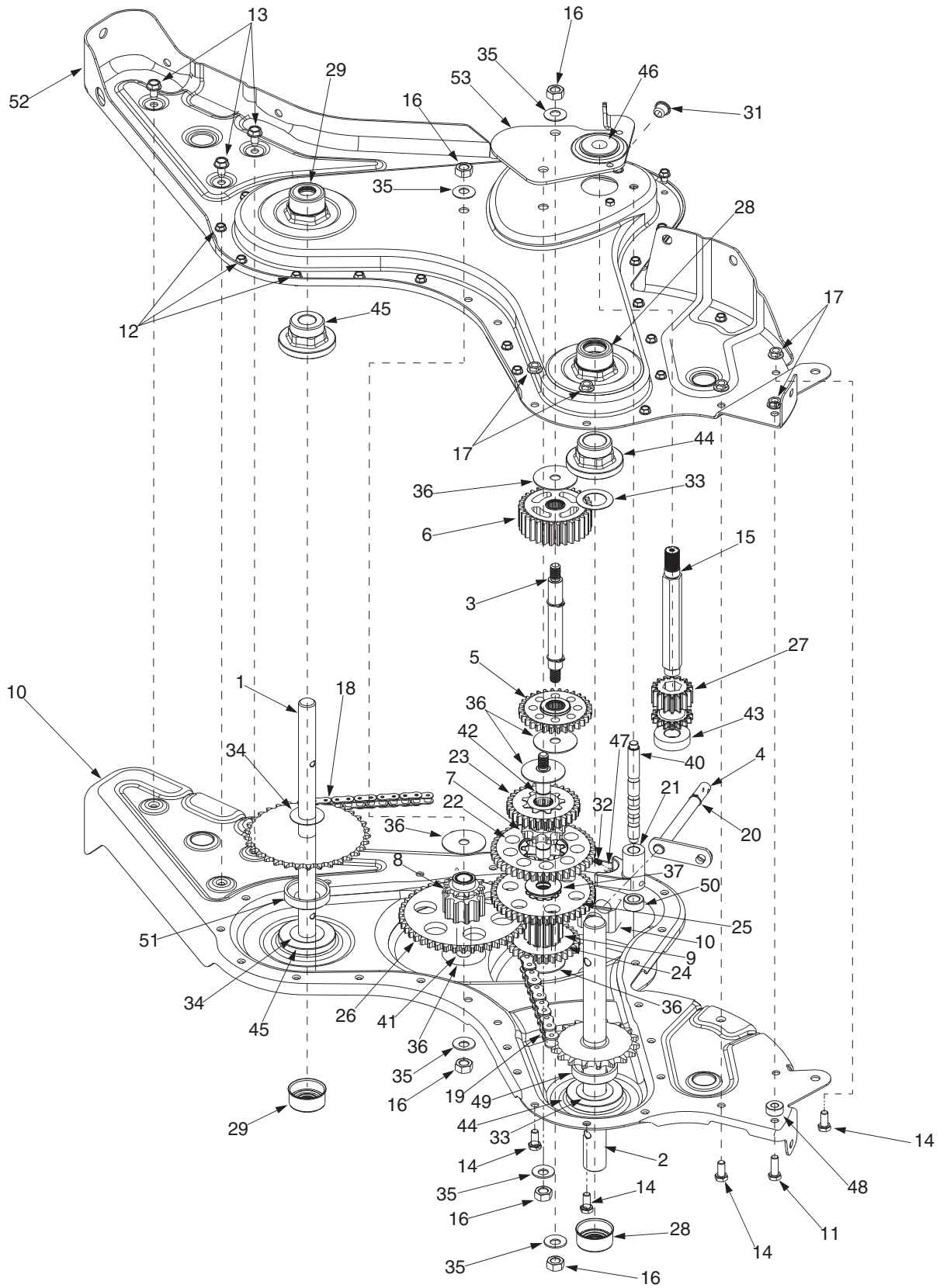

9

Illustrated Parts List Model RT 65

To order replacement parts, contact your local Cub Cadet dealer; or call our dealer locator number at 1 (877) 282-8684; or log onto www.cubcadet.com

Ref.	Part No.	Part Description
1.	611-04074	Wheel Shaft Ass'y 33T
2.	611-0021	Tine Shaft Ass'y: 18T
3.	611-0128	Jack Shaft Ass'y
4.	611-0129	Input Shaft Ass'y
5.	617-0058	Rev. Idler Gear Ass'y: 30T
6.	617-0059	Tine Idler Gear Ass'y: 30T
7.	617-0060	Tine Input Sprocket Ass'y: 9T
8.	617-0061	Wheel Input Sprocket Ass'y: 10T
9.	617-0062	Gear Ass'y: 11T
10.	686-0108	R.H. Housing Ass'y
11.	710-0376	Hex Bolt 5/16-18 x 1" Lg.
12.	710-0599	Hex S-Tap Scr. 1/4- 20 x.5"
13.	710-0604A	Hex S-Tap Scr. 5/16-18 x.625"
14.	710-3008	Hex Bolt 5/16-18 x.75"
15.	711-1349	Input Shaft
16.	712-0378	Hex Nut 7/16-20
17.	712-3004A	Flange Nut 5/16-18
18.	713-0367	#420 Chain 1/2 Pitch x 50 Links
19.	713-0484	#50 Chain 5/8 Pitch x 54 Links
20.	716-0865	Snap Ring
21.	717-0853	Shifting Fork
22.	717-1582	Spur Gear 44T
23.	717-1583	Spur Gear 30T
24.	717-1584	Spur Gear 30T
25.	717-1585	Spur Gear 44T
26.	717-1587	Spur Gear 44T

Ref.	Part No.	Part Description
27.	717-1594	Spur Gear 16T
28.	721-0378	Seal 1.0 Shaft
29.	721-0379	Seal.75 Shaft
31.	726-0277	Taper Cap Ring
32.	732-0496	Compression Spring.50" Leg.
33.	736-0163	Thrust Wash. 1.03" I.D. X. 1.62"
34.	736-0351	Fl-Wash.76" I.D. x 1.5" O.D.
35.	736-0407	Bell-Wash .45" I.D. x 1.0"
36.	736-0518	Thrust Wash. .445 x 1.92 x .060
37.	736-3088	Fl-Wash. .635" I.D. x 1.59 O.D.
40.	738-0645	Detent Shaft 1/2" Dia.
41.	738-0648	Jack Shaft .625 x 2.385
42.	738-1013	Jack Shaft .625 x 5.0
43.	741-0124	Ball Bearing
44.	741-0420	Flange Bearing 1.0 x 2.5 x 1.38
45.	741-0421	Flange Bearing .75 x 2.5 x 1.38
46.	741-0563	Ball Bearing .6692 x 5745 x .466
47.	741-0862	Detent Ball .250
48.	750-0258	Spacer .315
49.	750-0570	Spacer 1.0 I.D x 2.0 O.D. x .440
50.	750-0664	Spacer .505 I.D. x .88 O.D. x .440
51.	750-0671	Spacer .75 x 2.0 x .50
52.	786-0171	L.H. Chain Case Ass'y
53.	786-0238	Gear Positioner Bracket
	686-04074	Gear Case Assembly Complete

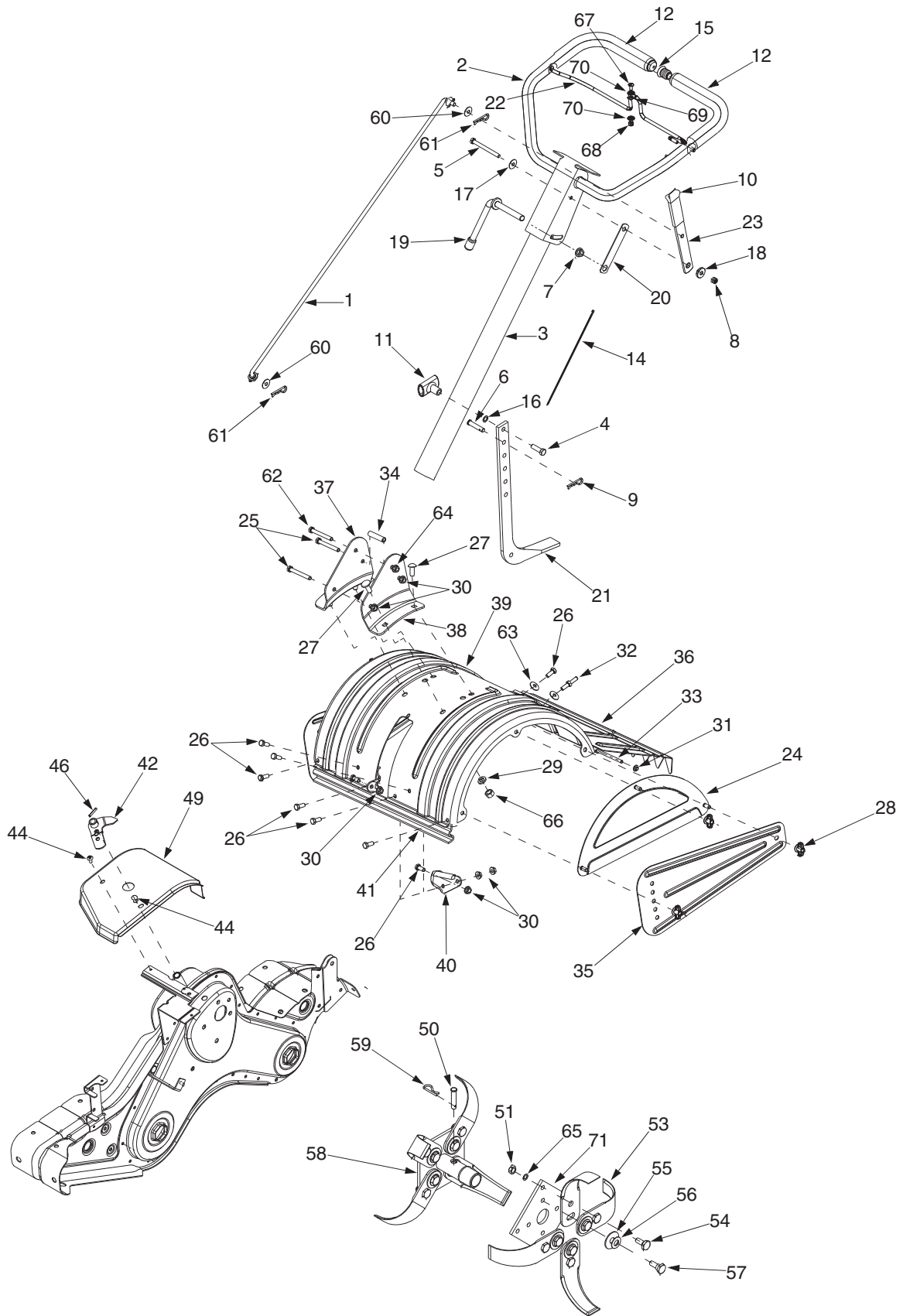

9

Illustrated Parts List Model RT 65

To order replacement parts, contact your local Cub Cadet dealer; or call our dealer locator number at 1 (877) 282-8684; or log onto www.cubcadet.com

Ref.	Part No.	Part Description	Ref.	Part No.	Part Description
1.	747-1152	Shift Rod	35.	786-0090	Shoulder
2.	649-0041	Upper Handle Ass'y	36.	786-0113	Tine Shield Hinge Flap
3.	649-0034	Lower Handle Ass'y	37.	786-0176	RH Handle Bracket
4.	710-3005	Hex Screw 3/8-16 x 1.25	38.	786-0177	LH Handle Bracket
5.	710-3056	Hex Screw 5/16-18 x 3.25	39.	786-0178	Tine Shield
6.	711-0415	Clevis Pin 3/8-1.62	40.	786-0179	Tine Shield Bracket
7.	712-0379	Flange Lock Nut 3/8-24	41.	786-0180	Shoulder Spacer Bracket
8.	712-0429	Hex Lock Nut 5/16-18	42.	686-0109	Shift Crank Ass'y
9.	714-0147	Cotter Pin	44.	710-1017	Screw 1/4-14 x .625
10.	720-0313	Grip	46.	715-0120	Spiral Pin 3/16 x 1.0
11.	720-0210A	T-Knob	49.	784-0208C	Shift Cover
12.	720-0278A	Foam Grip	50.	711-0415	Clevis Pin
14.	726-0317	Cable Tie	51.	712-3054	Hex Nut 3/8-24
15.	735-0246A	Plug	53.	742-0305	13" Articulating Tine
16.	736-0117	Flat Washer 3/8 ID x .620 OD	54.	738-0689	Shoulder Bolt
17.	736-0242	Bell Washer .340 ID x .872 OD	55.	736-0208	Flat Washer .51" ID x 1.50" OD
18.	738-0958	Shoulder Spacer	56.	736-0253	Bell Washer .515" ID x 1.14" OD
19.	784-0190	Handle Adjustment Crank	57.	738-0688	Shoulder Bolt
20.	784-0191	Hex Nut Retainer Bracket	58.	784-0160	Tine Adapter Ass'y 18"
21.	786-0120	Depth Stake	59.	714-0149B	Internal Cotter Pin
22.	747-1219	Bail Clutch	60.	735-0127	Rubber Washer
23.	786-0181	Shift Lever Rod	61.	714-0104	Cotter Pin
24.	686-0044A	Tine Shield Cover Ass'y	62.	710-3022	Hex Screw 3/8-16 x 2.75"
25.	710-0176	Hex Cap Screw 5/16-18 x 2.75	63.	736-0204	Flat Washer
26.	710-3008	Hex Cap Screw 5/16-18 x .750	64.	712-04065	Flange Nut 3/8-16
27.	710-3097	Carriage Bolt 3/8-16 x 1.0	65.	736-0169	Lock Washer
28.	712-0421	Wing Nut	66.	712-3017	Hex Nut 3/8-16
29.	736-0169	Lock Washer 3/8	67.	710-0946	Truss Screw 1/4-20 x .65
30.	712-04063	Flange Nut 5/16-18	68.	712-0324	Hex Lock Nut 1/4-20
31.	726-0106	Cap Nut	69.	726-0273	Battery Hose Clamp 5/16
32.	738-0849	Hex Screw 5/16-18 x .75"	70.	736-3090	Flat Washer .260 ID x .720 OD
33.	747-0432	Rod	71.	784-0161	Tine Adapter Plate
34.	750-0885A	Spacer .322 x .625 x 2.0			

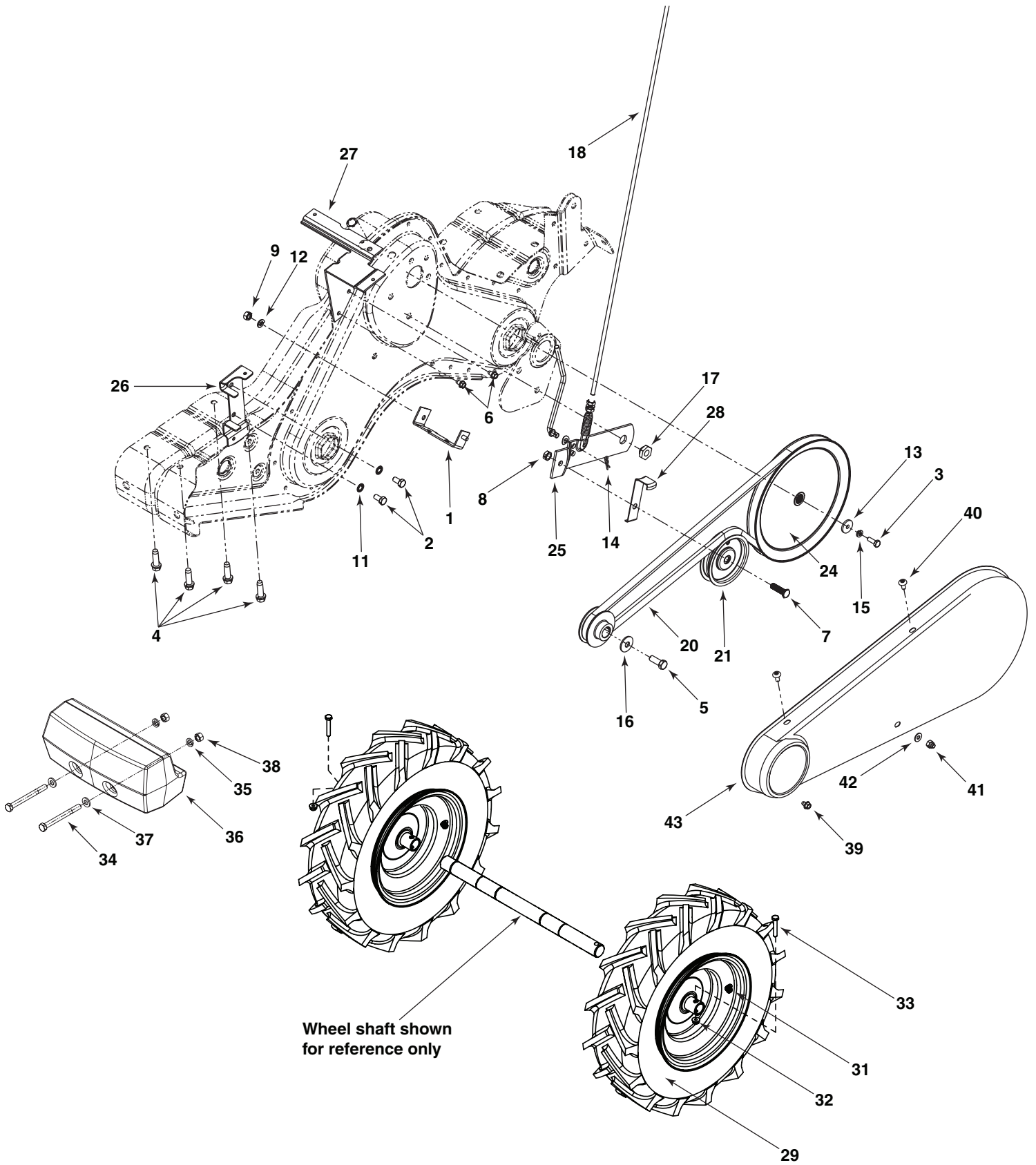

9

Illustrated Parts List Model RT 65

To order replacement parts, contact your local Cub Cadet dealer; or call our dealer locator number at 1 (877) 282-8684; or log onto www.cubcadet.com

Ref.	Part No.	Part Description	Ref.	Part No.	Part Description
1.	686-0111	Belt Cover Bracket Ass'y	23.	756-0972	Inner Engine Pulley Half
2.	710-0237	Hex Bolt 5/16-24 x .62"	24.	756-1162	Input Pulley
3.	710-0412	Hex Bolt 1/4-28 x .75"	25.	786-0064A	Idler Bracket
4.	710-0520	Hex Washer Screw 3/8-16 x 1.50"	26.	786-0185	Belt Keeper Bracket
5.	710-1039	Hex Bolt 3/8-24 x 1.0	27.	786-0187	Shift Cover Bracket
6.	710-0599	Hex Washer Screw	28.	786-0193	Idler Belt Keeper
7.	710-0723	Hex Cap Screw 3/8-16 x 1.25	29.	634-04231	Wheel Assembly 16.0 x 4.6 x 8
8.	712-0266	Lock Jam Nut 3/8-16		734-0808	Tire Only 16.2 x 4.6
9.	712-0267	Hex Nut 5/16-18	30.	634-04230	Wheel Rim Assembly
10.	714-0104	Internal Cotter Pin	31.	734-0255	Air Valve
11.	736-0104	Hairpin Clip	32.	710-0606	Hex Head Screw 1/4-20
12.	736-0119	Lock Washer 5/16"	33.	712-04064	Flange Lock Nut 1/4-20
13.	736-0176	Flat Washer .25 ID x .93 OD	34.	710-0382	Hex Bolt 1/2-13 x 5.0
14.	736-0271	Spring Washer .317 ID x .625 OD	35.	712-0206	Hex Nut 1/2-13
15.	736-0329	Lock Washer 1/4" ID	36.	723-0381	Counterweight 40 lbs.
16.	736-0452	Bell Washer .396 ID x 1.14 OD	37.	736-0326	Flat Washer
17.	738-0876	Shoulder Nut 7/16-20	38.	736-0921	Lock Washer 1/2
18.	746-1117	Clutch Cable	39.	710-0653	Hex Screw 1/4-20 x .375
19.	747-1159	Idler Pulley Rod	40.	710-1017	Screw 1/4-14 x .625
20.	754-0434	V-Belt	41.	712-0392	Lock Nut
21.	756-0405	Flat Idler w/Flange 3.75 OD	42.	736-3020	Flat Washer .271 ID x .630 OD
22.	756-0971	Outer Engine Pulley Half	43.	784-0158A	Belt Cover

NOTE: For painted parts, please refer to the list of color codes below. Please add the applicable color code, wherever needed, to the part number to order a replacement part. For instance, if a part numbered 700-xxxx is painted Cub Yellow, the part number to order would be 700-xxxx-0716.

Cub Yellow: 0716
Powder Black: 0637

MANUFACTURER'S LIMITED WARRANTY FOR

Cub Cadet®

The limited warranty set forth below is given by Cub Cadet LLC with respect to new merchandise purchased and used in the United States, its possessions and territories.

"Cub Cadet" warrants this product against defects in material and workmanship for a period of two (2) years commencing on the date of original purchase and will, at its option, repair or replace, free of charge, any part found to be defective in materials or workmanship. This limited warranty shall only apply if this product has been operated and maintained in accordance with the Operator's Manual furnished with the product, and has not been subject to misuse, abuse, commercial use, neglect, accident, improper maintenance, alteration, vandalism, theft, fire, water, or damage because of other peril or natural disaster. Damage resulting from the installation or use of any part, accessory or attachment not approved by Cub Cadet for use with the product(s) covered by this manual will void your warranty as to any resulting damage.

Normal wear parts are warranted to be free from defects in material and workmanship for a period of thirty (30) days from the date of purchase. Normal wear parts include, but are not limited to items such as: batteries, belts, blades, blade adapters, grass bags, rider deck wheels, seats, snow thrower skid shoes, shave plates, auger spiral rubber and tires.

HOW TO OBTAIN SERVICE: Warranty service is available, WITH PROOF OF PURCHASE, through your local authorized service dealer. To locate the dealer in your area, check your Yellow Pages, or contact Cub Cadet LLC at P.O. Box 361131, Cleveland, Ohio 44136-0019, or call 1-877-282-8684, or log on to our Web site at www.cubcadet.com.

This limited warranty does not provide coverage in the following cases:

- a. The engine or component parts thereof. These items may carry a separate manufacturer's warranty. Refer to applicable manufacturer's warranty for terms and conditions.
- b. Log splitter pumps, valves, and cylinders have a separate one year warranty.
- c. Routine maintenance items such as lubricants, filters, blade sharpening, tune-ups, brake adjustments, clutch adjustments, deck adjustments, and normal deterioration of the exterior finish due to use or exposure.
- d. Cub Cadet does not extend any warranty for products sold or exported outside of the United States, its possessions and territories, except those sold through Cub Cadet's authorized channels of export distribution

- e. Replacement parts that are not genuine Cub Cadet parts.
- f. Service completed by someone other than an authorized service dealer.
- g. Transportation charges and service calls.

No implied warranty, including any implied warranty of merchantability of fitness for a particular purpose, applies after the applicable period of express written warranty above as to the parts as identified. No other express warranty, whether written or oral, except as mentioned above, given by any person or entity, including a dealer or retailer, with respect to any product, shall bind Cub Cadet. During the period of the warranty, the exclusive remedy is repair or replacement of the product as set forth above.

The provisions as set forth in this warranty provide the sole and exclusive remedy arising from the sale. Cub Cadet shall not be liable for incidental or consequential loss or damage including, without limitation, expenses incurred for substitute or replacement lawn care services or for rental expenses to temporarily replace a warranted product.

Some states do not allow the exclusion or limitation of incidental or consequential damages, or limitations on how long an implied warranty lasts, so the above exclusions or limitations may not apply to you.

In no event shall recovery of any kind be greater than the amount of the purchase price of the product sold. **Alteration of safety features of the product shall void this warranty.** You assume the risk and liability for loss, damage, or injury to you and your property and/or to others and their property arising out of the misuse or inability to use the product.

This limited warranty shall not extend to anyone other than the original purchaser or to the person for whom it was purchased as a gift.

HOW STATE LAW RELATES TO THIS WARRANTY: This limited warranty gives you specific legal rights, and you may also have other rights which vary from state to state.

IMPORTANT: Owner must present Original Proof of Purchase to obtain warranty coverage.