

Cub Cadet.

OPERATOR'S MANUAL

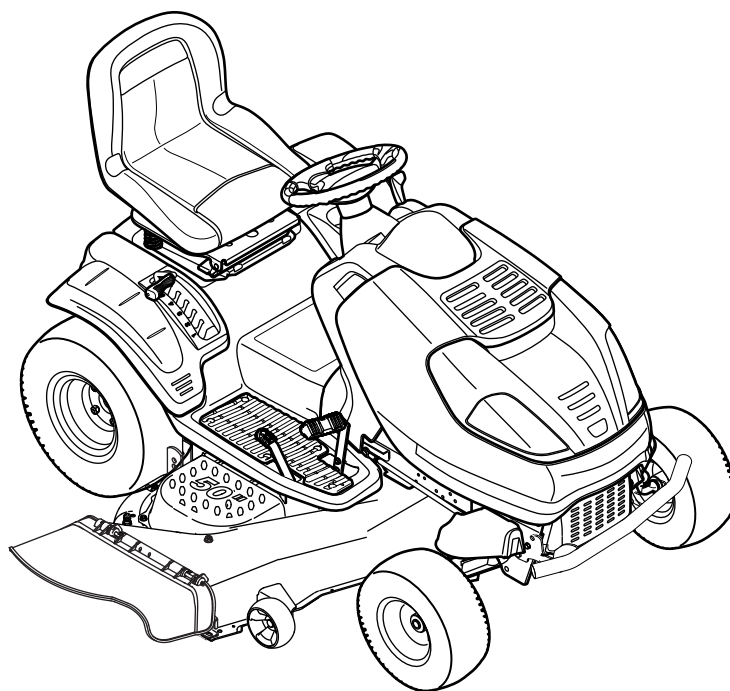

**Zero Turn Riding Mower
Time Saver Models**

i1046

i1050

⚠ WARNING

**READ AND FOLLOW ALL SAFETY RULES AND INSTRUCTIONS IN THIS MANUAL
BEFORE ATTEMPTING TO OPERATE THIS MACHINE.
FAILURE TO COMPLY WITH THESE INSTRUCTIONS MAY RESULT IN PERSONAL INJURY.**

CUB CADET LLC, P.O. BOX 361131 CLEVELAND, OHIO 44136-0019

Thank You

Thank you for purchasing a Lawn Tractor manufactured by Cub Cadet LLC. It was carefully engineered to provide excellent performance when properly operated and maintained.

Please read this entire manual prior to operating the equipment. It instructs you how to safely and easily set up, operate and maintain your machine. Please be sure that you, and any other persons who will operate the machine, carefully follow the recommended safety practices at all times. Failure to do so could result in personal injury or property damage.

All information in this manual is relative to the most recent product information available at the time of printing. Review this manual frequently to familiarize yourself with the machine, its features and operation. Please be aware that this Operator's Manual may cover a range of product specifications for various models. Characteristics and features discussed and/or illustrated in this manual may not be applicable to all models. Cub Cadet LLC reserves the right to change product specifications, designs and equipment without notice and without incurring obligation.

This product has met the rigid safety standards of the Outdoor Power Equipment Institute and an independent testing laboratory. If you have any problems or questions concerning the machine, phone your local Cub Cadet dealer or contact us directly. Cub Cadet's Customer Support telephone numbers, website address and mailing address can be found on this page. We want to ensure your complete satisfaction at all times.

Throughout this manual, all references to *right* and *left* side of the machine are observed from the operating position.

Table of Contents

Safe Operation Practices	3	Service	23
Assembly & Set-Up	8	Troubleshooting	28
Controls & Features	10	Replacement Parts	29
Operation.....	13	Attachments & Accessories	30
Maintenance & Adjustment	17	Warranties	31

Record Product Information

Before setting up and operating your new equipment, please locate the model plate on the equipment and record the information in the provided area to the right. You can locate the model plate by looking beneath the seat. This information will be necessary, should you seek technical support via our web site or with your local Cub Cadet dealer.

MODEL NUMBER

--	--	--	--	--	--	--	--	--	--	--	--

SERIAL NUMBER

--	--	--	--	--	--	--	--	--	--	--	--

Customer Support

If you have difficulty assembling this product or have any questions regarding the controls, operation, or maintenance of this machine, you can seek help from the experts. Choose from the options below:

- ◇ Visit us on the web at www.cubcadet.com
- ◇ Locate your nearest Cub Cadet Dealer at (877) 282-8684
- ◇ Write us at Cub Cadet LLC • P.O. Box 361131 • Cleveland, OH • 44136-0019



WARNING: This symbol points out important safety instructions which, if not followed, could endanger the personal safety and/or property of yourself and others. Read and follow all instructions in this manual before attempting to operate this machine. Failure to comply with these instructions may result in personal injury.

When you see this symbol. **HEED ITS WARNING!**

CALIFORNIA PROPOSITION 65



WARNING: Engine Exhaust, some of its constituents, and certain vehicle components contain or emit chemicals known to State of California to cause cancer and birth defects or other reproductive harm.



WARNING: Battery posts, terminals, and related accessories contain lead and lead compounds, chemicals known to the State of California to cause cancer and reproductive harm. *Wash hands after handling*



DANGER: This machine was built to be operated according to the rules for safe operation practices in this manual. As with any type of power equipment, carelessness or error on the part of the operator can result in serious injury. This machine is capable of amputating hands and feet and throwing objects. Failure to observe the following safety instructions could result in serious injury or death.

Children

1. Tragic accidents can occur if the operator is not alert to the presence of children. Children are often attracted to the machine and the mowing activity. They do not understand the dangers. Never assume that children will remain where you last saw them.
 - a. Keep children out of the mowing area and in watchful care of a responsible adult other than the operator.
 - b. Be alert and turn machine off if a child enters the area.
 - c. Before and while backing, look behind and down for small children.
 - d. Never carry children, even with the blade(s) shut off. They may fall off and be seriously injured or interfere with safe machine operation.
 - e. Use extreme care when approaching blind corners, doorways, shrubs, trees or other objects that may block your vision of a child who may run into the machine.
 - f. **To avoid back-over accidents, always disengage the cutting blade(s) before shifting into Reverse. If equipped, the "Reverse Caution Mode" should not be used when children or others are around.**
- g. Keep children away from hot or running engines. They can suffer burns from a hot muffler.
- h. Remove key when machine is unattended to prevent unauthorized operation.
2. Never allow children under 14 years of age to operate this machine. Children 14 and over should read and understand the instructions and safe operation practices in this manual and on the machine and should be trained and supervised by an adult.

Operation

Safe Handling of Gasoline:

1. To avoid personal injury or property damage use extreme care in handling gasoline. **Gasoline is extremely flammable and the vapors are explosive.** Serious personal injury can occur when gasoline is spilled on yourself or your clothes which can ignite. Wash your skin and change clothes immediately.
 - a. Use only an approved gasoline container.
 - b. Never fill containers inside a vehicle or on a truck or trailer bed with a plastic liner. Always place containers on the ground away from your vehicle before filling.

- c. When practical, remove gas-powered equipment from the truck or trailer and refuel it on the ground. If this is not possible, then refuel such equipment on a trailer with a portable container, rather than from a gasoline dispenser nozzle.
 - d. Keep the nozzle in contact with the rim of the fuel tank or container opening at all times until fueling is complete. Do not use a nozzle lock-open device.
 - e. Extinguish all cigarettes, cigars, pipes and other sources of ignition.
 - f. Never fuel machine indoors.
 - g. Never remove gas cap or add fuel while the engine is hot or running. Allow engine to cool at least two minutes before refueling.
 - h. Never over fill fuel tank. Fill tank to no more than ½ inch below bottom of filler neck to allow space for fuel expansion.
 - i. Replace gasoline cap and tighten securely.
 - j. If gasoline is spilled, wipe it off the engine and equipment. Move machine to another area. Wait 5 minutes before starting the engine.
 - k. To reduce fire hazards, keep machine free of grass, leaves, or other debris build-up. Clean up oil or fuel spillage and remove any fuel soaked debris.
 - l. Never store the machine or fuel container inside where there is an open flame, spark or pilot light as on a water heater, space heater, furnace, clothes dryer or other gas appliances.
 - m. Allow a machine to cool at least five minutes before storing.
- 7. Plan your mowing pattern to avoid discharge of material toward roads, sidewalks, bystanders and the like. Also, avoid discharging material against a wall or obstruction which may cause discharged material to ricochet back toward the operator.
 - 8. Always wear safety glasses or safety goggles during operation and while performing an adjustment or repair to protect your eyes. Thrown objects which ricochet can cause serious injury to the eyes.
 - 9. Wear sturdy, rough-soled work shoes and close-fitting slacks and shirts. Loose fitting clothes and jewelry can be caught in movable parts. Never operate this machine in bare feet or sandals.
 - 10. Be aware of the mower and attachment discharge direction and do not point it at anyone. Do not operate the mower without the discharge cover or entire grass catcher in its proper place.
 - 11. Do not put hands or feet near rotating parts or under the cutting deck. Contact with the blade(s) can amputate hands and feet.
 - 12. A missing or damaged discharge cover can cause blade contact or thrown object injuries.
 - 13. Stop the blade(s) when crossing gravel drives, walks, or roads and while not cutting grass.
 - 14. Watch for traffic when operating near or crossing roadways. This machine is not intended for use on any public roadway.
 - 15. Do not operate the machine while under the influence of alcohol or drugs.
 - 16. Mow only in daylight or good artificial light.
 - 17. Never carry passengers.
 - 18. Disengage blade(s) before shifting into reverse. Back up slowly. Always look down and behind before and while backing to avoid a back-over accident.
 - 19. Slow down before turning. Operate the machine smoothly. Avoid erratic operation and excessive speed.
 - 20. Disengage blade(s), set parking brake, stop engine and wait until the blade(s) come to a complete stop before removing grass catcher, emptying grass, unclogging chute, removing any grass or debris, or making any adjustments.
 - 21. Never leave a running machine unattended. Always turn off blade(s), place transmission in neutral, set parking brake, stop engine and remove key before dismounting.
 - 22. Use extra care when loading or unloading the machine into a trailer or truck. This machine should not be driven up or down ramp(s), because the machine could tip over, causing serious personal injury. The machine must be pushed manually on ramp(s) to load or unload properly.
 - 23. Muffler and engine become hot and can cause a burn. Do not touch.
 - 24. Check overhead clearances carefully before driving under low hanging tree branches, wires, door openings etc., where the operator may be struck or pulled from the machine, which could result in serious injury.

General Operation:

- 1. Read, understand, and follow all instructions on the machine and in the manual(s) before attempting to assemble and operate. Keep this manual in a safe place for future and regular reference and for ordering replacement parts.
- 2. Be familiar with all controls and their proper operation. Know how to stop the machine and disengage them quickly.
- 3. Never allow children under 14 years old to operate this machine. Children 14 years old and over should read and understand the operation instructions and safety rules in this manual and should be trained and supervised by a parent.
- 4. Never allow adults to operate this machine without proper instruction.
- 5. To help avoid blade contact or a thrown object injury, keep bystanders, helpers, children and pets at least 75 feet from the machine while it is in operation. Stop machine if anyone enters the area.
- 6. Thoroughly inspect the area where the equipment is to be used. Remove all stones, sticks, wire, bones, toys, and other foreign objects which could be picked up and thrown by the blade(s). Thrown objects can cause serious personal injury.

25. Disengage all attachment clutches, depress the brake pedal completely and shift into neutral before attempting to start engine.
26. Your machine is designed to cut normal residential grass of a height no more than 10". Do not attempt to mow through unusually tall, dry grass (e.g., pasture) or piles of dry leaves. Dry grass or leaves may contact the engine exhaust and/or build up on the mower deck presenting a potential fire hazard.
27. Use only accessories and attachments approved for this machine by the machine manufacturer. Read, understand and follow all instructions provided with the approved accessory or attachment.
28. Data indicates that operators, age 60 years and above, are involved in a large percentage of riding mower-related injuries. These operators should evaluate their ability to operate the riding mower safely enough to protect themselves and others from serious injury.
29. If situations occur which are not covered in this manual, use care and good judgment. Contact your customer service representative for assistance.

Slope Operation:

Slopes are a major factor related to loss of control and tip-over accidents which can result in severe injury or death. All slopes require extra caution. If you cannot back up the slope or if you feel uneasy on it, do not mow it.

For your safety, use the slope gauge included as part of this manual to measure slopes before operating this machine on a sloped or hilly area. If the slope is greater than 15 degrees as shown on the slope gauge, do not operate this machine on that area or serious injury could result.

Do:

1. Mow up and down slopes, not across. Exercise extreme caution when changing direction on slopes.
2. Watch for holes, ruts, bumps, rocks, or other hidden objects. Uneven terrain could overturn the machine. Tall grass can hide obstacles.
3. Use slow speed. Choose a low enough speed setting so that you will not have to stop or shift while on the slope. Tires may lose traction on slopes even though the brakes are functioning properly. Always keep machine in gear when going down slopes to take advantage of engine braking action.
4. Follow the manufacturer's recommendations for wheel weights or counterweights to improve stability.
5. Use extra care with grass catchers or other attachments. These can change the stability of the machine.
6. Keep all movement on the slopes slow and gradual. Do not make sudden changes in speed or direction. Rapid engagement or braking could cause the front of the machine to lift and rapidly flip over backwards which could cause serious injury.
7. Avoid starting or stopping on a slope. If tires lose traction, disengage the blade(s) and proceed slowly straight down the slope.

Do Not:

1. Do not turn on slopes unless necessary; then, turn slowly and gradually downhill, if possible.
2. Do not mow near drop-offs, ditches or embankments. The mower could suddenly turn over if a wheel is over the edge of a cliff, ditch, or if an edge caves in.
3. Do not try to stabilize the machine by putting your foot on the ground.
4. Do not use a grass catcher on steep slopes.
5. Do not mow on wet grass. Reduced traction could cause sliding.
6. Do not shift to neutral and coast downhill. Over-speeding may cause the operator to lose control of the machine resulting in serious injury or death.
7. Do not tow heavy pull behind attachments (e.g. loaded dump cart, lawn roller, etc.) on slopes greater than 5 degrees. When going down hill, the extra weight tends to push the tractor and may cause you to lose control. (e.g. tractor may speed up, braking and steering ability are reduced, attachment may jack-knife and cause tractor to overturn).

Towing:

1. Tow only with a machine that has a hitch designed for towing. Do not attach towed equipment except at the hitch point.
2. Follow the manufacturer's recommendation for weight limits for towed equipment and towing on slopes.
3. Never allow children or others in or on towed equipment.
4. On slopes, the weight of the towed equipment may cause loss of traction and loss of control.
5. Travel slowly and allow extra distance to stop.
6. Do not shift to neutral and coast downhill.

Service

1. Never run an engine indoors or in a poorly ventilated area. Engine exhaust contains carbon monoxide, an odorless, and deadly gas.
2. Before cleaning, repairing, or inspecting, make certain the blade(s) and all moving parts have stopped. Disconnect the spark plug wire and ground against the engine to prevent unintended starting.
3. Periodically check to make sure the blades come to complete stop within approximately (5) five seconds after operating the blade disengagement control. If the blades do not stop within the this time frame, your machine should be serviced professionally by an authorized MTD Service Dealer.
4. Check brake operation frequently as it is subjected to wear during normal operation. Adjust and service as required.

5. Check the blade(s) and engine mounting bolts at frequent intervals for proper tightness. Also, visually inspect blade(s) for damage (e.g., excessive wear, bent, cracked). Replace the blade(s) with the original equipment manufacturer's (O.E.M.) blade(s) only, listed in this manual. "Use of parts which do not meet the original equipment specifications may lead to improper performance and compromise safety!"
6. Mower blades are sharp. Wrap the blade or wear gloves, and use extra caution when servicing them.
7. Keep all nuts, bolts, and screws tight to be sure the equipment is in safe working condition.
8. Never tamper with the safety interlock system or other safety devices. Check their proper operation regularly.
9. After striking a foreign object, stop the engine, disconnect the spark plug wire(s) and ground against the engine. Thoroughly inspect the machine for any damage. Repair the damage before starting and operating.
10. Never attempt to make adjustments or repairs to the machine while the engine is running.
11. Grass catcher components and the discharge cover are subject to wear and damage which could expose moving parts or allow objects to be thrown. For safety protection, frequently check components and replace immediately with original equipment manufacturer's (O.E.M.) parts only, listed in this manual. "Use of parts which do not meet the original equipment specifications may lead to improper performance and compromise safety!"
12. Do not change the engine governor settings or over-speed the engine. The governor controls the maximum safe operating speed of the engine.
13. Maintain or replace safety and instruction labels, as necessary.
14. Observe proper disposal laws and regulations for gas, oil, etc. to protect the environment.

Do not modify engine

To avoid serious injury or death, do not modify engine in any way. Tampering with the governor setting can lead to a runaway engine and cause it to operate at unsafe speeds. Never tamper with factory setting of engine governor.

Notice Regarding Emissions

Engines which are certified to comply with California and federal EPA emission regulations for SORE (Small Off Road Equipment) are certified to operate on regular unleaded gasoline, and may include the following emission control systems: Engine Modification (EM) and Three Way Catalyst (TWC) if so equipped.

Spark Arrestor



WARNING: This machine is equipped with an internal combustion engine and should not be used on or near any unimproved forest-covered, brushcovered or grass-covered land unless the engine's exhaust system is equipped with a spark arrester meeting applicable local or state laws (if

any).

If a spark arrester is used, it should be maintained in effective working order by the operator. In the State of California the above is required by law (Section 4442 of the California Public Resources Code). Other states may have similar laws. Federal laws apply on federal lands.

A spark arrester for the muffler is available through your nearest engine authorized service dealer or contact the service department, P.O. Box 361131 Cleveland, Ohio 44136-0019.

Average Useful Life

According to the Consumer Products Safety Commission (CPSC) and the U.S. Environmental Protection Agency (EPA), this product has an *Average Useful Life* of seven (7) years, or 270 hours of operation. At the end of the *Average Useful Life*, buy a new machine or have the machine inspected annually by an authorized service dealer to ensure that all mechanical and safety systems are working properly and not worn excessively. Failure to do so can result in accidents, injuries or death.



WARNING: Your Responsibility—Restrict the use of this power machine to persons who read, understand and follow the warnings and instructions in this manual and on the machine.

SAVE THESE INSTRUCTIONS!

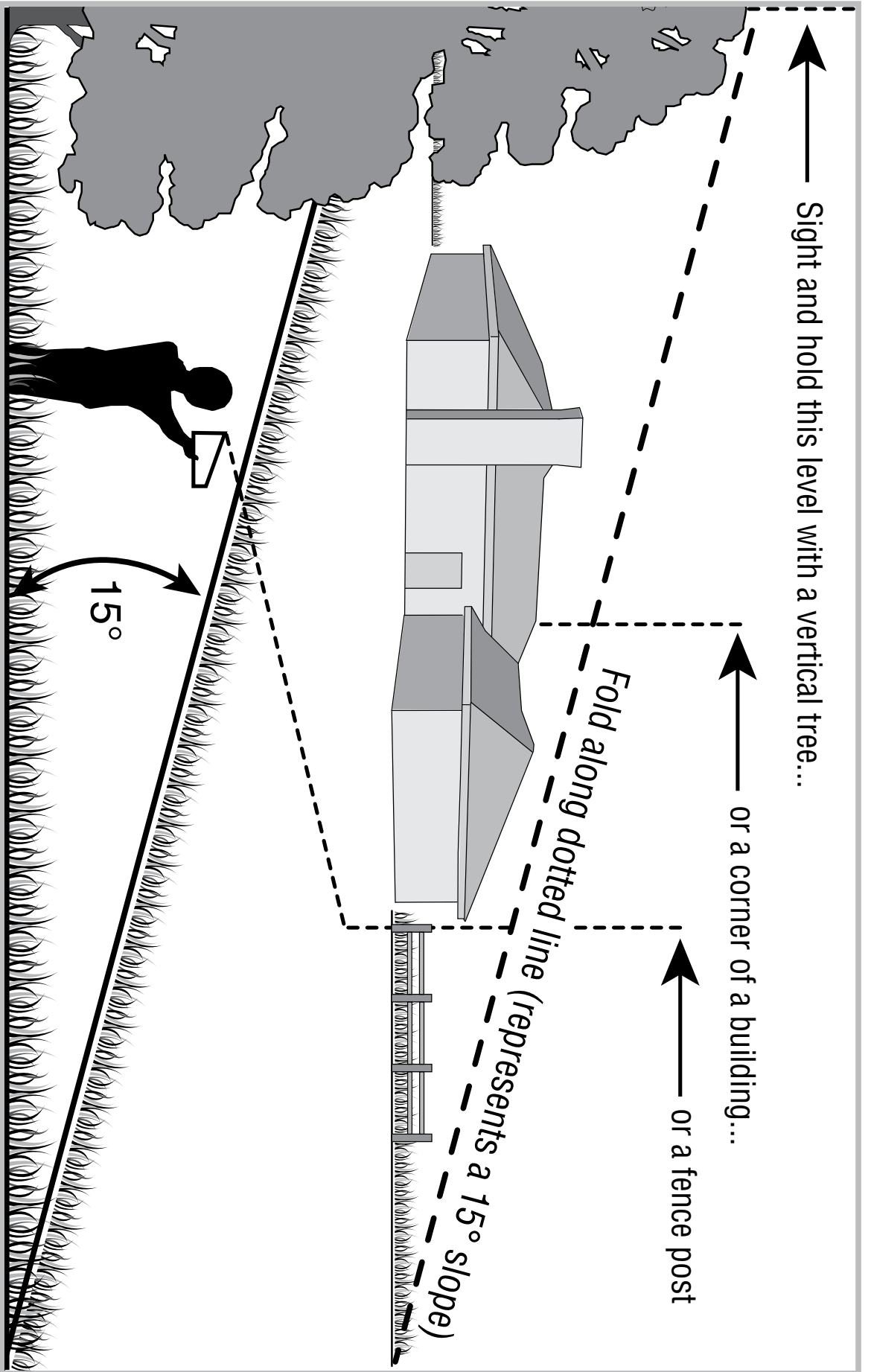

Use this page as a guide to determine slopes where you may not operate safely.

WARNING: Do not operate your lawn mower on such slopes. Do not mow on inclines with a slope in excess of 15 degrees (a rise of approximately 2-1/2 feet every 10 feet). A riding mower could overturn and cause serious injury. Operate riding mowers up and down slopes, never across the face of slopes.

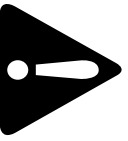

Opening the Tractor Hood

To attach the negative battery cable and check the engine oil level the hood must be open. Locate the hood lift notch at the front/center of the dash panel. Grasping the hood at the notch, lift and pivot the hood forward to open.

Attaching the Battery Cables

The tractor is shipped with an activated sealed battery. The positive battery cable is factory connected. The negative cable must be connected. The positive battery terminal is marked Pos. (+). The negative battery terminal is marked Neg. (-).

IMPORTANT: Make sure the ignition switch is in the "OFF" position before attaching the battery cables.

- From the center notch at the front of the dash panel, lift the tractor hood and pivot forward to open.
- Remove the hex shoulder bolt and wing nut from the negative (black) cable.

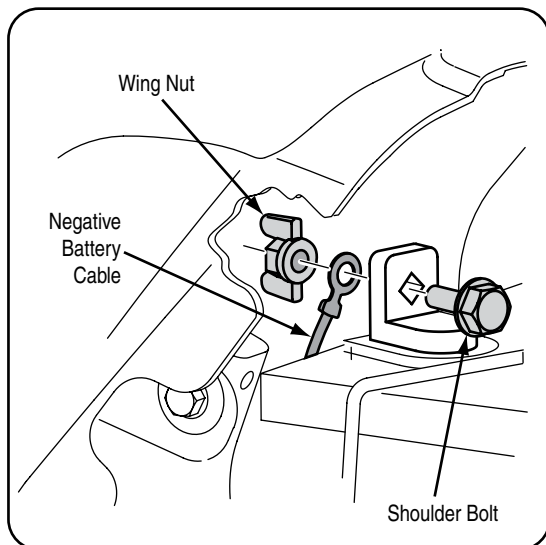

Figure 3-1

- Pull the protective cap, if present, off the negative battery terminal. Attach the negative cable (heavy black wire) to the negative battery terminal (-) with the bolt and wing nut. See Figure 1.
- The positive cable (red cable) is secured to the positive battery terminal (+) with a carriage bolt and hex nuts at the factory. Make certain that the rubber boot covers the positive battery terminal.

NOTE: If the battery is put into service after the date shown on top of battery, charge the battery as instructed on page 20 of this manual prior to operating the tractor.

Gasoline Fill-up



WARNING: Use extreme care when handling gasoline. Gasoline is extremely flammable and the vapors are explosive. Never fuel machine indoors or while the engine is hot or running. Extinguish cigarettes, cigars, pipes, and other sources of ignition.

NOTE: Purchase gasoline in small quantities. Do not use gasoline left over from the previous season, to minimize gum deposits in the fuel system.

- This engine is certified to operate on unleaded gasoline. For best results, fill the fuel tank with only clean, fresh, unleaded gasoline with a pump sticker octane rating of 87 or higher. In countries using the Research method, it should be 90 octane minimum.
- Unleaded gasoline is recommended because it leaves less combustion chamber deposits and reduces harmful exhaust emissions. Leaded gasoline is not recommended and must not be used where exhaust emissions are regulated.
- Gasohol (up to 10% ethyl alcohol, 90% unleaded gasoline by volume) is an approved fuel. Other gasoline/alcohol blends are not approved.
- Methyl Tertiary Butyl Ether (MTBE) and unleaded gasoline blends (up to a maximum of 15% MTBE by volume) are approved fuels. Other gasoline/ether blends are not approved.

The gasoline tank is under the rear fender, with the fuel fill cap located in the center of the rear fender. The fuel cap is tethered to the tractor to prevent its loss. Do not attempt to remove the cap from the tractor.

IMPORTANT: Your tractor is shipped with motor oil in the engine. However, you **MUST** check the oil level before operating. Refer to the engine Owner's Manual provided with your tractor for instructions on checking the oil level.

Tire Pressure



WARNING: Maximum tire pressure under any circumstances is 25 psi. Equal tire pressure should be maintained at all times.

The tires on your unit may be over-inflated for shipping purposes. Reduce the tire pressure before operating the tractor. Recommended operating tire pressure is approximately 10 p.s.i for the rear tires & 14 p.s.i. for the front tires. Check sidewall of tire for maximum p.s.i.

Mulching Plug & Shipping Brace Removal



WARNING! Make sure the riding mower's engine is off, remove the ignition key, and set the parking brake before removing the shipping brace.



WARNING! The shipping brace, used for packaging purposes only, must be removed and discarded before operating your riding mower.



WARNING! The mowing deck is capable of throwing objects. Never operate the mower deck without the chute deflector in its down position, even with the mulching plug installed. Failure to do so could result in serious personal injury and/or property damage.

Removing Mulching Plug & Shipping Brace From 46" Decks ONLY

- Remove the wing nut and carriage bolt securing the mulching plug in the deck discharge opening, and pull the mulching plug from the deck. See Figure 3-2.

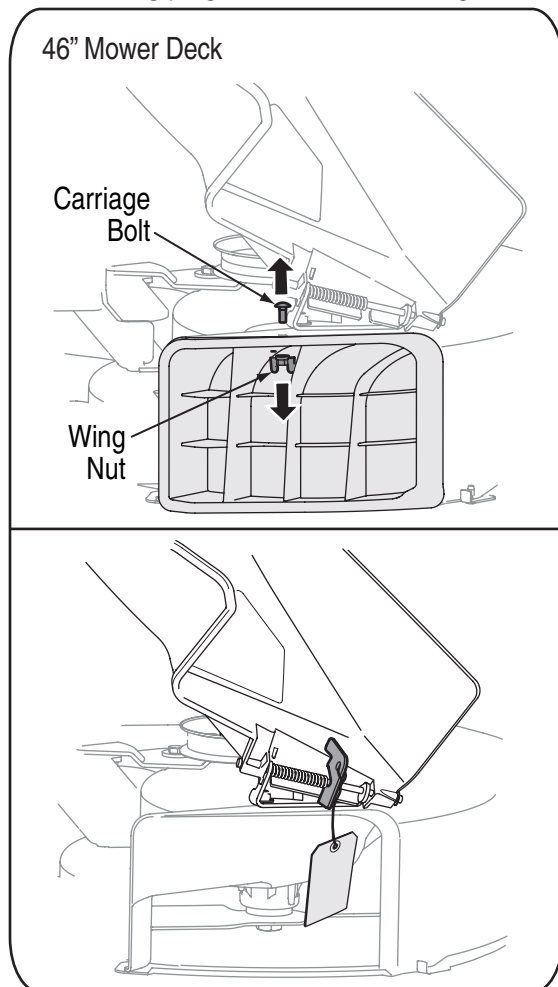

Figure 3-2

- Locate the shipping brace and tag, if present, between the chute deflector and the cutting deck. Holding the chute deflector fully upward, remove the shipping by grasping it and rotating it clockwise. Lower the chute deflector. Refer to Figure 2.

Removing Mulching Plug & Shipping Brace From 50" Decks ONLY

- Fully raise and hold the chute deflector; then slide the mulching plug out of the deck discharge opening. Lower the chute deflector.
- Locate the shipping brace and tag, if present, between the chute deflector and the cutting deck. Holding the chute deflector fully upward, remove the shipping brace by grasping it and rotating it. Lower the chute deflector. Refer to Figure 3-3.

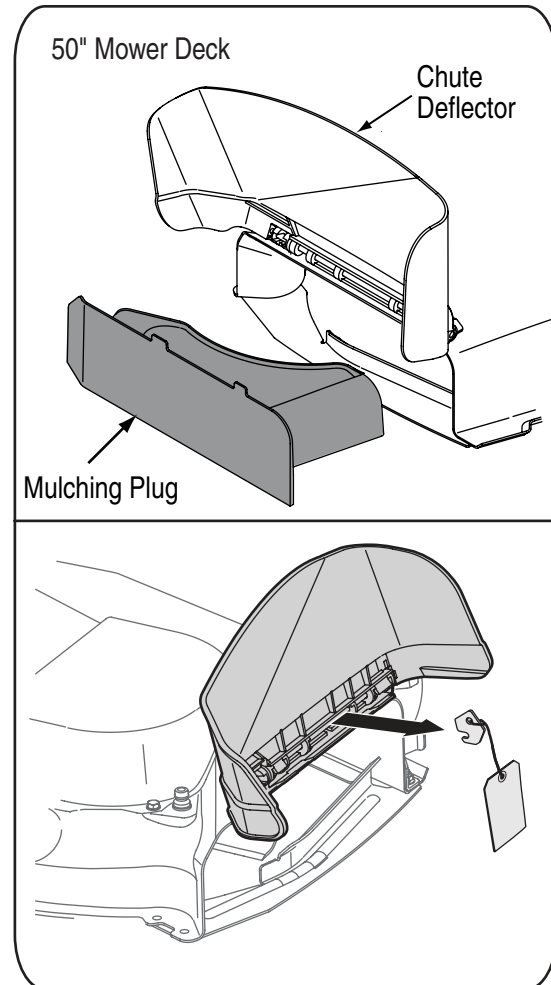

Figure 3-3

Store the mulching plug for future use. Refer to "Mulching" in "Operation" for instructions on installing and using the mulching feature.

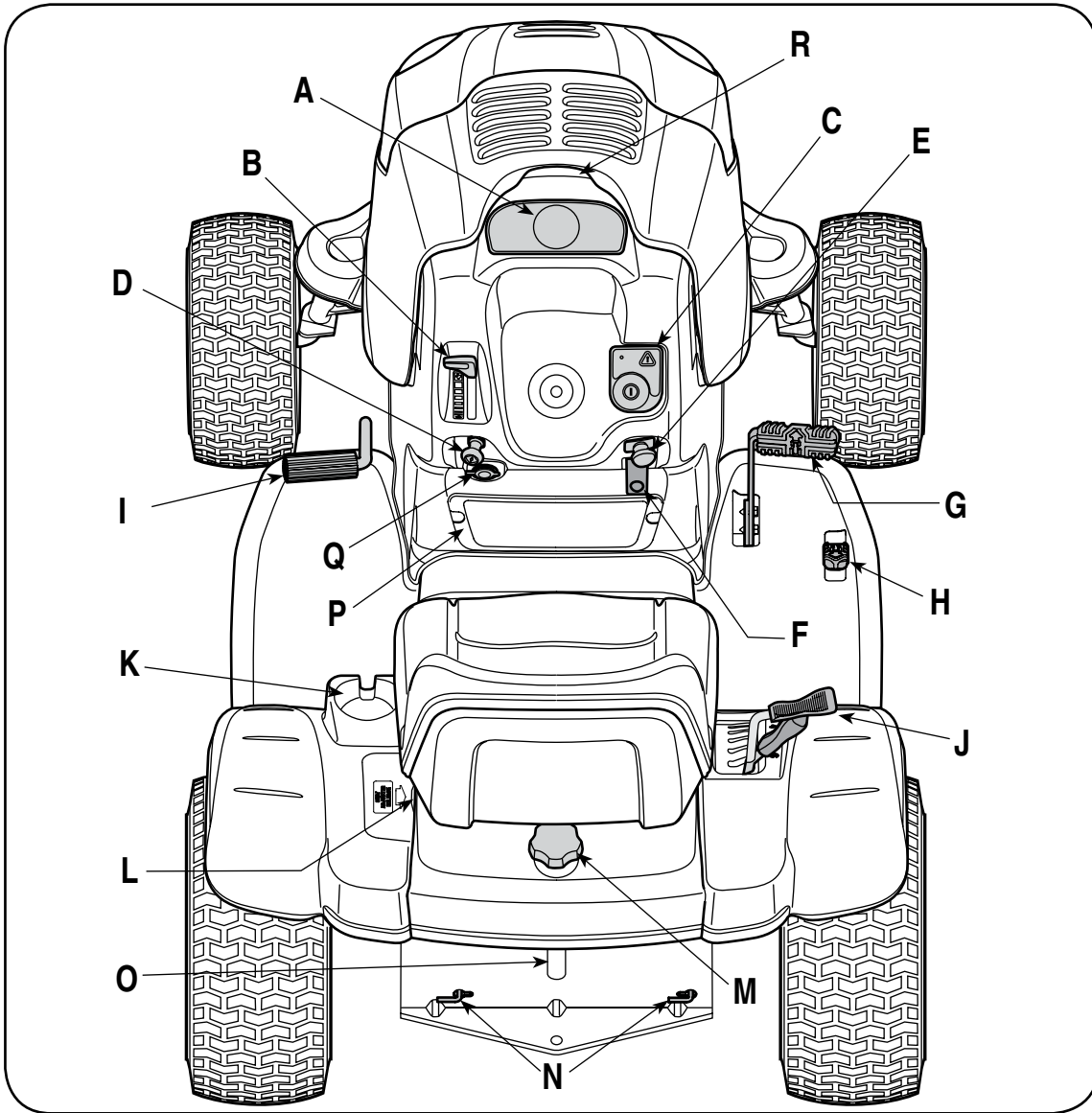

Figure 4-1

A	Systems Indicator Monitor/ Hour Meter	J	Deck Lift Lever
B	Throttle Control Lever	K	Cup Holder
C	Key Switch Module	L	Seat Adjustment Lever
D	Choke Control Knob	M	Fuel Fill Cap
E	PTO (Blade Engage)Control Switch	N	Hydro Transmission Bypass Rods
F	Parking Brake Lever	O	Fuel Level Window
G	Forward Control Pedal	P	Cargo Net
H	Reverse Control Pedal	Q	12 V Power Outlet
I	Brake Pedal	R	Hood Lift Notch

NOTE: Any reference in this manual to the RIGHT or LEFT side of the tractor is observed from operator's position.

Systems Indicator Monitor/Hour Meter

Your tractor is equipped with a Systems Indicator Monitor as shown in Figure 5. The monitor records the accumulated hours of tractor operation, and displays the information on the LCD hour meter display (tenths of an hour - right most digit). The monitor also has four indicator lights that show the status of various functions of the tractor.

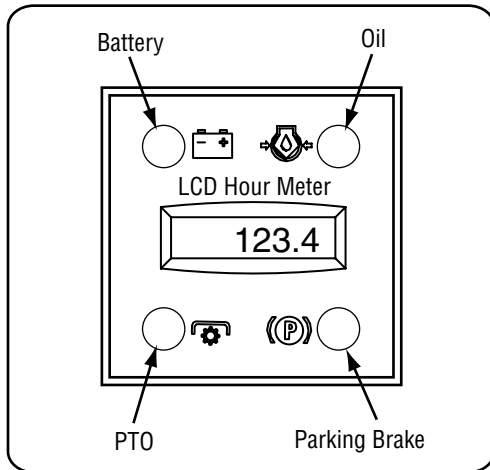

Figure 4-2

The system indicator monitor features are as follows:

LCD Hour Meter Display

The hour meter display is activated when the key switch is turned to either the "NORMAL MOWING" or the "REVERSE CAUTION MODE" switch positions. When the key switch is turned to an on position, the battery indicator light briefly illuminates and the battery voltage is briefly displayed. The display then changes to the accumulated hours.

NOTE: A record of the actual hours of operation should be kept to assure maintenance procedures are completed according to the schedule in this manual. The Indicator Monitor will also remind the operator of maintenance intervals for changing the engine oil. The LCD will alternately flash the recorded hours, "CHG" and "OIL" for five minutes, after every 50 hours of recorded operation elapse. The maintenance interval lasts for two hours (from 50-52, 100-102, 150-152, etc.). The LCD will flash as described for five minutes every time the tractor's engine is started during this maintenance interval. Follow the oil change intervals provided in the engine manual.

Battery Indicator Light

Illuminates when the ignition switch is turned to an ON position and the engine is not started.

Illuminates to indicate the battery voltage has dropped below 11.5 (+0.5/-1.0) DC volts (the battery voltage is also displayed on the hour meter). If this indicator and display come on during operation, check the battery and charging system for possible causes and/or contact your Cub Cadet dealer.

Oil Pressure Indicator Light

This warning lamp indicates low engine oil pressure. If this indicator illuminates, stop the tractor immediately

and check the engine oil level. If the oil level is within the operating range, but the light remains on, contact your Cub Cadet dealer. **NOTE:** The oil pressure indicator may illuminate when the key switch is turned to an on position, but should turn off when the engine is started.

PTO Engaged Indicator Light

This indicator illuminates when the key switch is turned to the "START" position while the PTO switch is in the "ENGAGED" position. Check this indicator if the engine will not crank with the key switch in the "START" position. Move the PTO switch to the "DISENGAGED" position.

Brake Engaged Indicator

This indicator illuminates when the key switch is turned to the "START" position and the brake pedal is not fully depressed. Check this indicator if the engine will not crank with the key switch in the "START" position. If necessary, fully depress the brake pedal.

Throttle Control Lever

The throttle control lever controls the speed of the engine. When set in a given position, the throttle will maintain a uniform engine speed.

IMPORTANT: When operating the tractor with the cutting deck engaged, throttle control lever must always be in the FAST (rabbit) position.

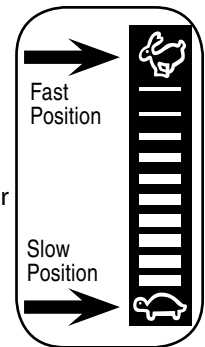

Key Switch Module

The key switch module is used to start and stop the engine. It is also used to activate the REVERSE CAUTION MODE. Insert key into the key switch module and turn clockwise to the START position. Release the key into the NORMAL MOWING position once engine has started.

To stop the engine, turn the ignition key counterclockwise to the STOP position.

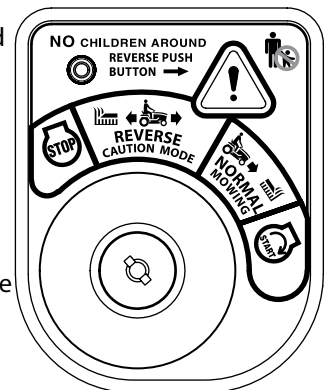

WARNING: Never leave a running machine unattended. Always disengage PTO, move shift lever into neutral position, set parking brake, stop engine and remove key to prevent unintended starting.

IMPORTANT: Prior to operating the tractor, refer to both "Safety Interlock System" on page 12 and "Starting The Engine" on page 13 of this manual for detailed instructions regarding the Ignition Switch Module and operating the tractor in REVERSE CAUTION MODE.



WARNING: Never move the key into the Start position while the engine is running. Doing so may cause damage to your engine's starter.

Choke Control

The choke control knob is located on the lower left side of the dash panel and is activated by pulling outward. Activating the choke control closes the choke plate on the carburetor and aids in starting the engine.

PTO (Blade Engage) Control Switch

To engage the electric PTO and provide power to the cutting deck, pull outward on the PTO control switch knob. Push the switch knob inward to disengage the PTO and stop the cutting deck.

NOTE: The PTO Control Switch must be in the disengaged (OFF) position when starting the engine.

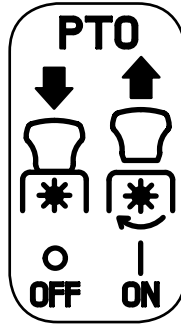

Parking Brake Lever

NOTE: The parking brake must be set if the operator leaves the seat with the engine running; otherwise the engine will automatically shut off.

- To set the parking brake, fully depress the brake pedal and push the bottom of parking brake lever inward. See the image to the right for parking brake identification. Hold the lever in while removing your foot from the brake pedal. Both parking brake lever and brake pedal will stay depressed.
- To release the parking brake, depress the brake pedal slightly. The parking brake lever will then return to its original position.



IMPORTANT: Always set the parking brake when leaving the tractor unattended.

Forward Control Pedal

The forward control pedal is located on the right side of the tractor, at the front of the right running board. Depress the forward control pedal to cause the tractor to travel in the forward direction. The forward ground speed of the tractor is directly affected by the distance the pedal is depressed. The further the pedal is depressed, the faster the tractor will travel. The tractor will slow and the pedal will return to its original position when released.

Reverse Control Pedal

The reverse control pedal is located in the right front running board rearward of the forward control pedal. Depress the reverse control pedal to cause the tractor to travel in reverse. The further the pedal is depressed, the faster the tractor will travel. The tractor will slow and the pedal will return to its original position when released.

Brake Pedal

The brake pedal is located at the front of the left running board and is used for quick stops, or setting the parking brake. This pedal must be FULLY depressed to activate the safety interlock switch when starting the tractor.

Deck Lift Lever

The deck lift lever is located in the right fender and is used to change the cutting height of the mower deck. The cutting heights range from 1-1/2" to 4". Each of the six index notches represent an approximately 1/2" adjustment to the deck height. To use, grasp the lift lever handle and pull slightly upward (rearward) while pivoting the lever inward and out of its index notch. Move the lift lever as necessary to place in the notch best suited for your application.

After changing the cutting height of the deck, you must check the position of the deck front gauge wheels. They should be approximately 1/2-inch above the ground when the tractor is on a smooth, flat surface such as a driveway. Refer to "Maintenance & Adjustments" later in this manual.

Cup Holder

The tractor's cup holder is located on the fender to the left of the seat.

Seat Adjustment Lever

The seat adjustment lever is on the left side of the seat. Use this lever to adjust the seat forward or rearward to a comfortable operating position. See the "Maintenance & Adjustments" section later in this manual for instructions.

Fuel Fill Cap and Fuel Level Window

The fuel fill cap is located in the center of the rear fender. Pivot the seat forward to fully access the fuel fill cap and fill the fuel tank.

Turn the fill cap approximately 1/4 turn and pull upward to remove. Push the cap downward on the fuel tank fill neck and turn 1/4 turn clockwise to tighten. The level of fuel in the fuel tank can be viewed through the fuel level window in the rear hitch plate.

Cargo Net

Conveniently located on the tractor's dash panel, the cargo net can be used to store personal items while operating the lawn tractor.

Hydro Transmission Bypass Rods

The hydro transmission bypass rods are located at the back of the tractor above the rear hitch plate. When engaged, these levers open a hydro pump bypass valve in each transmission which allows the tractor to be manually pushed short distances. See the "Maintenance & Adjustments" section later in this manual for instructions.

12V Power Outlet

The 12V power outlet is located below the choke control on the left side of the dash panel. It is used for the convenience of plugging in accessories that require a power source with a maximum load of 5 amps at 12 volts.



WARNING

AVOID SERIOUS INJURY OR DEATH

- GO UP AND DOWN SLOPES, NOT ACROSS.
- AVOID SUDDEN TURNS.
- DO NOT OPERATE THE UNIT WHERE IT COULD SLIP OR TIP.
- IF MACHINE STOPS GOING UPHILL, STOP BLADE(S) AND BACK DOWNHILL SLOWLY.
- DO NOT MOW WHEN CHILDREN OR OTHERS ARE AROUND.
- NEVER CARRY CHILDREN, EVEN WITH BLADES OFF.
- LOOK DOWN AND BEHIND BEFORE AND WHILE BACKING.
- KEEP SAFETY DEVICES (GUARDS, SHIELDS, AND SWITCHES) IN PLACE AND WORKING.
- REMOVE OBJECTS THAT COULD BE THROWN BY THE BLADE(S).
- KNOW LOCATION AND FUNCTION OF ALL CONTROLS.
- BE SURE BLADE(S) AND ENGINE ARE STOPPED BEFORE PLACING HANDS OR FEET NEAR BLADE(S).
- BEFORE LEAVING OPERATOR'S POSITION, DISENGAGE BLADE(S), PLACE THE SHIFT LEVER IN NEUTRAL, ENGAGE BRAKE LOCK, SHUT ENGINE OFF AND REMOVE KEY.

READ OPERATOR'S MANUAL

Headlights

The tractor headlights are turned on whenever the ignition switch is turned to either of the run positions.

Safety Interlock System

The safety interlock system is designed for safe operation of the tractor. If this system should ever malfunction, do not operate the tractor, immediately contact your Cub Cadet dealer.

- The safety interlock system prevents the engine from starting unless the parking brake is engaged and the PTO switch is in the disengaged (OFF) position.
- The safety interlock system will automatically shut off the engine if the operator leaves the seat before engaging the parking brake.
- The safety interlock system will automatically shut off the engine if the operator leaves the tractor's seat with the PTO (Blade Engage) switch engaged, regardless of whether the parking brake is engaged.
- With the ignition key in the NORMAL MOWING position, the electric PTO clutch will automatically shut off if the PTO switch is in the engaged (ON) position and the drive pedal is depressed for Reverse travel.



WARNING: Tampering with or attempting to bypass the Safety Interlock Switches in any way will void your tractor's warranty. Do not operate the tractor if the interlock system is malfunctioning.

Reverse Caution Mode



WARNING: Use extreme caution while operating the tractor in the REVERSE CAUTION MODE. Always look down and behind before and while backing. Do not operate the tractor when children or others are around. Stop the tractor immediately if someone enters the area.

The **REVERSE CAUTION MODE** position of the key switch module allows the tractor to be operated in reverse with the blades (PTO) engaged.

IMPORTANT: Mowing in reverse is not recommended.

To use the REVERSE CAUTION MODE:

IMPORTANT: The operator **MUST** be seated in the tractor seat.

1. Start engine as instructed in the following sub section.
2. Turn the key from the NORMAL MOWING (Green) position to the REVERSE CAUTION MODE (Yellow) position of the key switch module. See Figure 5-1.

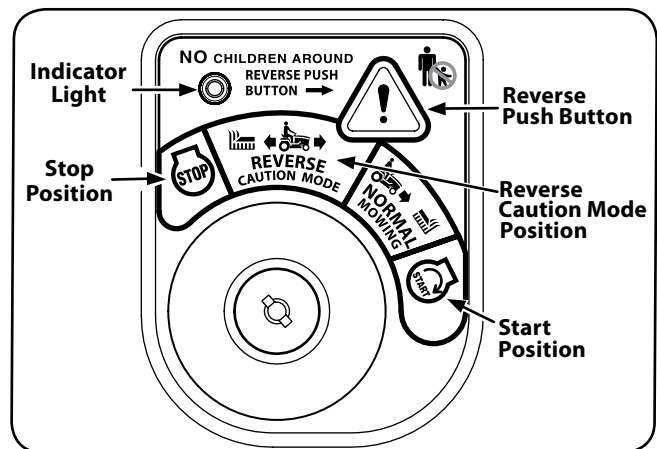

Figure 5-1

3. Depress the REVERSE PUSH BUTTON (Orange, Triangular Button) at the top, right corner of the key switch module. The red indicator light at the top, left corner of the key switch module will be ON while activated. See Figure 5-1.
4. Once activated (indicator light ON), the tractor can be driven in reverse with the cutting blades (PTO) engaged.
5. Always look down and behind before and while backing to make sure no children are around.
6. After resuming forward motion, return the key to the NORMAL MOWING position.

IMPORTANT: The **REVERSE CAUTION MODE** will remain activated until:

- a. The key is placed in either the NORMAL MOWING position or STOP position.
- b. The operator leaves the seat. Follow the previous instructions to re-activate.

Starting the Engine



WARNING: Do not operate the tractor if the interlock system is malfunctioning. This system was designed for your safety and protection.

NOTE: Refer to the engine Owner's Manual for gasoline and oil fill-up instructions.

1. Insert the tractor key into the key switch module.
2. Disengage the PTO (Blade Engage) lever/knob.
3. Engage the tractor's parking brake.
4. Pull the choke control knob outward into the full choke position (a warm engine may not require choking).
5. Move the throttle control lever to midway between the SLOW and FAST positions.
6. Turn the ignition key clockwise to the START position. After the engine starts, release the key. It will return to the NORMAL MOWING position.

IMPORTANT: Do not hold the key in the START position for longer than ten seconds at a time. Doing so may cause damage to your engine's electric starter.

7. After the engine starts, gradually push the choke knob fully inward as the engine warms up.

NOTE: Do not use the choke control to enrich the fuel mixture, except as necessary to start and warm up the engine.

IMPORTANT

Do not leave the seat of the tractor without

1. Disengaging PTO lever
2. Depressing brake pedal
3. Engaging parking brake

If leaving the tractor unattended, also turn the ignition key off and remove the key.

Avoid sudden starts, excessive speed and sudden stops while driving the tractor.

Do not mow on slope in excess of 15 degrees (a rise of approximately 2-1/2 feet every 10 feet).

Keep hands and feet away from the opening of the cutting deck.

Plan your mowing pattern to avoid discharge of materials toward roads, sidewalks, bystanders and the like. Also, avoid discharging material against a wall or obstruction which may cause discharged material to ricochet back toward the operator.

Stopping the Engine



WARNING: If you strike a foreign object, stop the engine and disconnect the spark plug wire(s). Thoroughly inspect the machine for any damage. Repair the damage before restarting and operating

1. If the blades are engaged, disengage the PTO.
2. Move the throttle control lever to midway between the half and full throttle. Then turn the ignition key counterclockwise to the OFF position.
3. Remove the key from the ignition switch to prevent unintended starting.

Driving The Tractor

IMPORTANT: Avoid sudden starts, excessive speed and sudden stops.

- Briefly depress the brake pedal to release the parking brake. Move the throttle lever into the FAST (rabbit) position.
- To travel forward: Slowly depress the forward drive control pedal until the desired speed is achieved. See Figure 5-2.

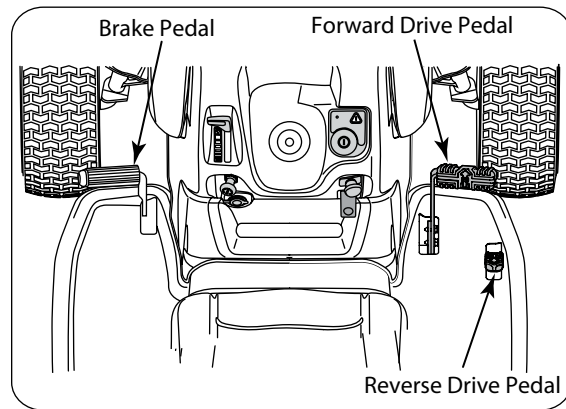

Figure 5-2

- To travel in reverse: Check that the area behind is clear, then slowly depress the reverse drive control pedal until the desired speed is achieved. See Figure 5-2.
- Release the depressed drive pedal and depress the brake pedal to stop the tractor.



WARNING! Do not leave the seat of the tractor without first placing the PTO/Blade Engage knob in the disengaged (OFF) position and engaging the parking brake. If leaving the tractor unattended, also turn the engine off and remove the ignition key.

Steering the Tractor

Your i1000 series tractor is equipped with an innovative steering system. Turning the steering wheel not only turns the front wheels, but also adjusts the position of the drive control linkage of the two hydro transmissions that drive the tractor. This steering system allows you to vary the radius of turns from a normal wide U-turn down to a zero turn. Some practice may be needed to become accustomed to the steering of your tractor. The steering works as follows:

- The steering wheel turns approximately two turns stop to stop. With the center position being the straight ahead position.
- Minor turns of the steering wheel from the center position (approximately 10° to 15°) turn only the front axles and will result in wider turns.
- Increasing the turn of the steering wheel (beyond 10°-15°) results in increasingly tighter turns. As the steering mechanism turns the front wheels, it also changes the position of the transmission drive control linkage to slow down the inner rear wheel in the turn, and adjust the speed of the outer wheel as necessary to complete

the desired turn. Turn the steering wheel back to the center position as the turn is completed.

NOTE: It is not necessary to release the drive pedal when making a turn. The change to the transmission linkage occurs regardless of how far the drive pedal is depressed. When the steering wheel is straightened, the tractor will return to the speed set by the drive pedal.

- Turning the steering wheel fully to its stop in either direction will fully turn the front wheels, reverse the direction of the inner wheel and adjust the outer wheel speed to execute a zero turn in the chosen direction. Turn the steering wheel back to the center position as the turn is completed.

NOTE: As the steering wheel is turned further toward its stop, the effort needed to turn the steering wheel increases.

IMPORTANT: Making tight or zero turns on grass will greatly increase the potential for defacement of the turf.

Driving On Slopes

IMPORTANT: Refer to the SLOPE GAUGE on page 7 to help determine slopes where you may operate the tractor safely.

- Mow up and down slopes, never across.
- Watch for holes, ruts, bumps, rocks, or other hidden objects. Uneven terrain could overturn the machine. Tall grass can hide obstacles.
- Avoid turns when driving on a slope. If a turn must be made, turn downhill on the slope. Turning uphill increases the possibility of a tractor rollover.
- Avoid stopping when driving up a slope. If it is necessary to stop while driving up a slope, start up smoothly and carefully to reduce the possibility of flipping the tractor over backward.

Engaging the Parking Brake

NOTE: The parking brake must be set if the operator leaves the seat with the engine running or the engine will automatically shut off.

To set the parking brake:

1. Press the brake pedal completely down with your right foot and hold it that position.
2. Push the parking brake lever downward and hold it in that position.
3. Remove your foot from the brake pedal.
4. Release pressure from the parking brake lever.

After completing step 3, the brake pedal should remain in the down position. If it doesn't, the parking brake is not engaged. Repeat steps 1-4 to engage the parking brake.

To disengage the parking brake, lightly press the brake pedal.



WARNING: Never leave a running machine unattended. Always disengage PTO, set parking brake, stop engine and remove key to prevent unintended starting

Engaging the PTO

Engaging the PTO transfers power to the cutting deck or other (separately available) attachments. To engage the PTO:

1. Move the throttle control lever to the FAST (rabbit) position.
2. Pull the PTO/Blade Engage knob outward into the engaged (ON) position.

NOTE: Always operate the tractor with the throttle lever in the FAST (rabbit) position for the most efficient use of the cutting deck or other (separately available) PTO driven attachments.

Mowing



WARNING: To help avoid blade contact or a thrown object injury, keep bystanders, helpers, children and pets at least 75 feet from the machine while it is in operation. Stop machine if anyone enters the area.

This tractor is equipped with one of Cub Cadet's high quality cutting decks. The following information will be helpful when using the cutting deck with your tractor.

- Do not mow at high ground speed, especially if a mulch kit or grass collector is installed.
- For best results it is recommended that the first two laps be cut with the discharge thrown towards the center. After the first two laps, reverse the direction to throw the discharge to the outside for the balance of cutting. This will give a better appearance to the lawn.
- Do not cut the grass too short. Short grass invites weed growth and yellows quickly in dry weather.
- Mowing should always be done with the engine at full throttle.
- Under heavier conditions it may be necessary to go back over the cut area a second time to get a clean cut.
- Do not attempt to mow heavy brush and weeds and extremely tall grass. Your tractor is designed to mow lawns, not clear brush.
- Keep the blades sharp and replace the blades when worn. Refer to the "SERVICE" section of this manual for proper blade sharpening instructions.

IMPORTANT: When stopping the tractor for any reason while on a grass surface, always

- Place the shift lever in neutral,
- Engage the parking brake,
- Shut engine off and remove the key.

Doing so will minimize the possibility of having your lawn "browned" by hot exhaust from your tractor's running engine.

Mulching

The i1000 series tractor decks are equipped with a mulching kit. The mulch kit which incorporates special blades, already on your tractor, in a process of recirculating grass clippings repeatedly beneath the cutting deck. The ultra-fine clippings are then forced back into the lawn where they act as a natural fertilizer.

Observe the following points for best results when mulching:

- Never attempt to mulch if the lawn is damp. Wet grass tends to stick to the underside of the cutting deck preventing proper mulching of the clippings.
- Do not attempt to mulch more than 1/3 the total height of the grass or approximately 1-1/2 inches. Doing so will cause the clippings to clump up beneath the deck and not be mulched effectively.
- Maintain a slow ground speed to allow the grass clippings more time to effectively be mulched.
- Always position throttle control lever in the FAST (rabbit) position and allow it to remain there while mowing. Failing to keep the engine at full throttle places strain on the tractor's engine and does not allow the blades to properly mulch grass.

NOTE: It is not necessary to remove the chute deflector to operate the mower with the mulch plug installed.

- The mulch plug installed at the factory was removed earlier in the "Setting up your Lawn Tractor" section. To reinstall the mulching plug, proceed as follows:

Installing Mulching Plug on 46" Decks ONLY

- Raise and hold the chute deflector in up position.
- Locate the 1/4 inch hole in the top of the mulching plug. With the hole facing upward insert the mulching plug fully into the discharge opening of the deck.

- Align the mulching plug hole with the hole in the top of the deck discharge. Insert the carriage bolt through the top of the deck and the mulching plug and secure with the wing nut. Refer to Figure 3-2 on page 9.

Installing Mulching Plug on 50" Decks ONLY

- Pivot the chute deflector up to access the deck discharge opening.
- Locate two notches in the chute deflector hinge bracket above the deck discharge opening.
- Insert the mulch plug into the deck discharge opening. Make sure the two tabs on the top of the plug are in the notches of the hinge bracket. Lightly tap on the plug with your hand to assure that the tabs fit snugly into the notches.
- While holding the mulching plug in position, fully lower the chute deflector. Refer to Figure 3-3 on page 9.



WARNING! The mowing deck is capable of throwing objects. Never operate the mower deck without the chute deflector in its down position, even with the mulching plug installed. Failure to do so could result in serious personal injury and/or property damage.

Maintenance



WARNING! Before performing any maintenance or repairs, disengage the PTO, move the drive control levers fully outward in the neutral position, engage the parking brake, stop the engine and remove the key to prevent unintended starting.

Engine

Refer to the Kohler Owner's Manual for all engine maintenance intervals, procedures, specifications and instructions.

Changing the Engine Oil



WARNING! If the engine has been recently run, the engine, muffler and surrounding metal surfaces will be hot and can cause burns to the skin. Exercise caution to avoid burns.

To complete an oil change, proceed as follows:

1. Run the engine for a short time to warm the engine oil. The oil will flow more freely and carry away more impurities. Use care to avoid burns from hot oil.
2. Locate the oil drain port on the right side of the engine.
3. Pop open the protective cap on the end of the oil drain valve to expose the drain port. See Figure 6-1. Remove the oil fill cap/dipstick from the oil fill tube.

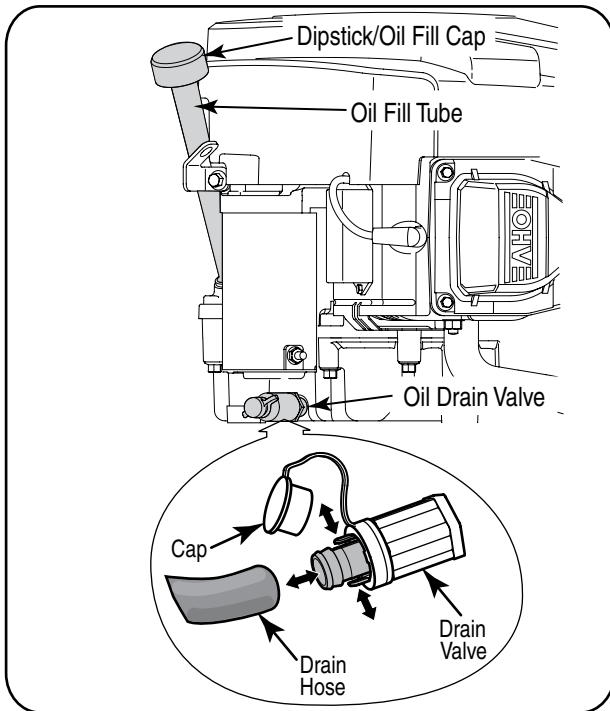

Figure 6-1

4. Push the oil drain hose (packed with this manual) onto the oil drain port. Route the opposite end of the hose into an appropriate oil collection container with at least a 2.5 quart capacity, to collect the used oil.

5. Pinch the tabs on the oil drain valve, then pull outward to begin draining oil. Refer to Figure 6-1.
6. After the oil has finished draining, push the end of the oil drain valve back in, until the tabs click into place. Re-cap the end of the oil drain valve to keep debris from entering the drain port.
7. Replace the oil filter, and refill the engine with new oil as instructed in the Kohler Owner's Manual.

Air Cleaner

Service the pre-cleaner and cartridge/air cleaner element as instructed in the Kohler Owner's Manual.

Spark Plug

The spark plugs should be cleaned and the gap reset once a season. Refer to the Kohler Owner's Manual for correct plug type and gap specifications.

Hydrostatic Transmission

The zero turn tractor is equipped with dual integrated hydrostatic pumps/transaxles that are sealed and are maintenance-free. Fluid levels cannot be checked and fluid cannot be added or changed.

Steering Lubrication

The steering arms, pivot shafts, and axles must be lubricated if ever the steering effort increases, or after every 25 hour of operation. Lubricate using a pressure grease gun and Cub Cadet 251H EP grease, or an equivalent No. 2 multipurpose lithium grease.

- Apply grease through the lube fitting on the RH and LH steering arms which are located at rearward end of the two steering drag links. See Figure 6-2.

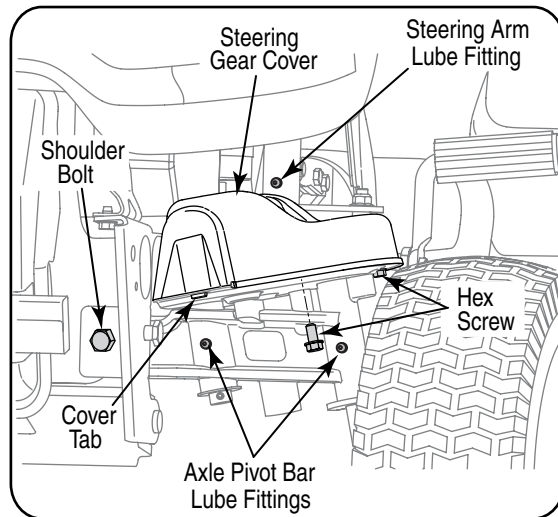

Figure 6-2

- Locate the lube fittings for the pivot shaft and axle on the front of one end of the axle pivot bar. Apply grease through the two lube fittings, then repeat to lubricate the other end of the pivot bar. See Figure 6-2.

Cleaning Steering Gears

Once a year, or if a tight spot is experienced when turning the steering wheel, remove the steering gear cover on each end of the pivot bar and clean the two steering gears.

- From beneath the cover base plate on each end of the pivot bar, remove the three hex screws securing the steering gear cover. Remove the covers and clean the gears. It is not necessary to lubricate the gears. Refer to Figure 6-2.
- Insert the tab of the LH steering gear cover into the square hole in the LH base plate, position the cover, and secure with the three hex screws. Do not over tighten. Repeat to install the cover on the RH side.

Lubricate Front Wheel Bearings

Lubricate the front wheel bearings with Cub Cadet 251H EP grease after every 25 hours of operation. The lube fittings are located in the rim hub inside each front wheel.

Lubricate Deck Spindles and Idler Bracket

Lubricate the deck spindles and idler bracket with Cub Cadet 251H EP grease after every 10 hours of operation.

The deck spindle lube fittings are in the spindle housings, and can only be accessed from the underside of the deck. Lubricate the idler bracket through the lube fitting in the top of the shoulder bolt. Use a pressure grease gun to lubricate the spindles and idler bracket.

Lubricate Pivot Points & Linkage

Lubricate all the pivot points on the drive system, parking brake and lift linkage at least once a season with light oil.

Lubricate Rear Wheels

The rear wheels should be removed from the axles once a season. Lubricate the axles and the rims well with an all-purpose grease before re-installing them.

Tires



WARNING: Never exceed the maximum inflation pressure shown on the sidewall of tire. Refer to the tire sidewall for exact tire manufacturer's recommended or maximum psi. Do not overinflate.

The recommended operating tire pressure is:

- Approximately 10 psi for the rear tires
- Approximately 14 psi for the front tires

IMPORTANT: Uneven tire pressure could cause the cutting deck to mow unevenly.

Cleaning the Tractor and Deck

Any fuel or oil spilled on the machine should be wiped off promptly. Do NOT allow debris to accumulate around the deck pulleys or any other part of the machine.

Periodically remove the belt covers and remove any accumulated grass clippings from around the spindle pulleys and the deck belt.

IMPORTANT: The use of a pressure washer to clean your tractor is NOT recommended. It may cause damage to electrical components, spindles, pulleys, bearings or the engine.

Using Deck Wash System™

Use the Deck Wash System™ to rinse grass clippings from the deck's underside and prevent the buildup of corrosive chemicals. Your tractor's deck is equipped with a water nozzle on the left end of the deck.

Complete the following steps AFTER EACH MOWING:

1. Drive the tractor to a level, clear spot on your lawn, near enough to a water sillcock (spigot) for your garden hose to reach.

IMPORTANT: Make certain the tractor's discharge chute is directed AWAY from your house, garage, parked cars, etc.

2. Disengage the PTO (Blade Engage), set the parking brake, and stop the engine.
3. Thread the nozzle adapter (packaged with your tractor's Operator's Manual) onto the end of your garden hose.
4. Pull back the lock collar of the nozzle adapter and push the adapter onto the deck wash nozzle at the left end of the mower deck. Release the lock collar to lock the adapter on the nozzle. See Figure 6-3.

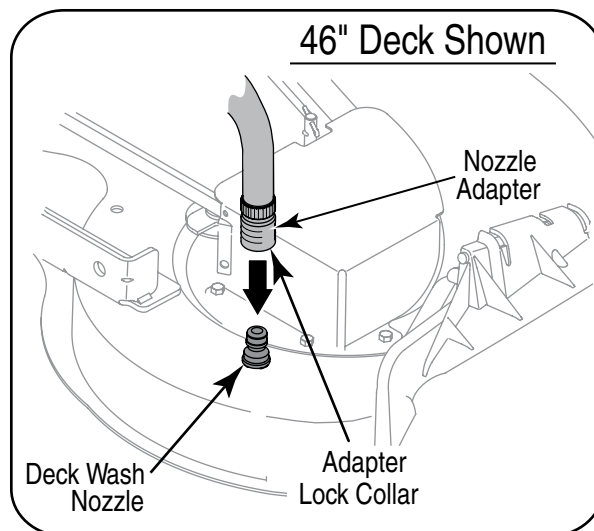

Figure 6-3

5. Turn the water on.
6. While sitting in the operator's position on the tractor, re-start the engine and place the throttle lever in the FAST (rabbit) position.
7. Move the tractor's PTO (Blade Engage) into the ON position. Remain in the operator's position with the cutting deck engaged for a minimum of two minutes, allowing the underside of the cutting deck to thoroughly rinse.
8. Move the tractor's PTO (Blade Engage) into the OFF position. Turn the ignition key to the STOP position to turn the tractor's engine off.
9. Pull back the lock collar of the nozzle adapter to disconnect the adapter from the nozzle.
10. Repeat the previous steps 4 thru 9 to clean the deck using the nozzle at the other end of the deck.

Moving the Tractor Manually

If for any reason the tractor will not drive or you wish to move the tractor, engage the two hydro transmission bypass rods to manually move the tractor short distances.

IMPORTANT: Never tow or drag the tractor with the rear wheels on the ground. Even with the bypass rods engaged. Doing so will damage the transmissions.

To engage a bypass rod, pull the rod rearward so that the flange on the rod passes through the larger/rounded part of the keyhole slot. With the flange of the rod outside (rearward) of the hitch plate, push the rod inward in the small part of the keyhole slot so that rod's flange is locked against the back of the hitch plate. Repeat to engage the other bypass rod to allow the tractor to be manually moved. See Figure 6-4.

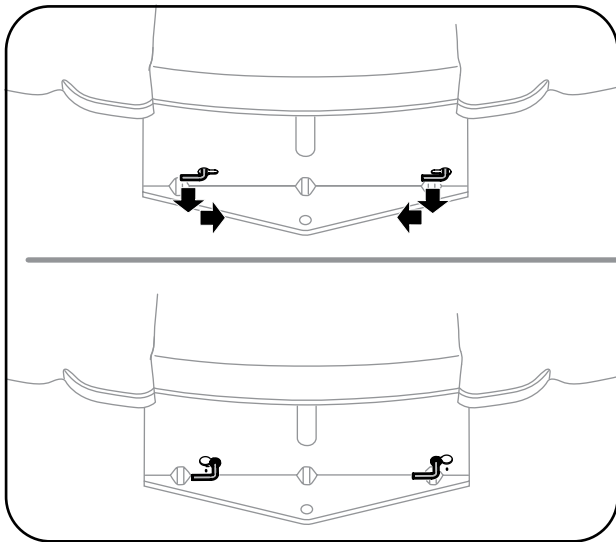

Figure 6-4

To disengage, move the rod to align its flange with the larger/rounded part of the keyhole slot and release the rod back through the hitch plate.

NOTE: The transmission will NOT engage when the hydrostatic bypass rod is pulled out. Return the rod to its normal position prior to operating the tractor.

Adjustments



WARNING: Never attempt to make any adjustments while the engine is running, except where specified in the operator's manual. Disconnect spark plug wire(s) before performing any adjustments, repairs or maintenance.

Steering and Transmission Linkage

The steering tie rod and drag links and the related transmission linkage are set at the factory and should not require further adjustment. Because of the complex adjustment procedure, the steering and transmission linkage should only be serviced or adjusted by a qualified mechanic. If you experience problems with steering, or with the hydro drive transmissions, contact your nearest Cub Cadet dealer to have the tractor inspected.

Adjusting the Seat



WARNING: After adjusting the seat or before driving the tractor, make sure that the seat adjustment lever is engaged in the seat index plate and that the seat will not move. Do not adjust the seat while the tractor is being driven. Adjusting the seat while the tractor is moving could cause the operator to lose control of the tractor.

1. While sitting in the seat, grasp the seat adjustment lever on the left side of the seat and pull it upward to disengage from the seat index plate. See Figure 6-5.

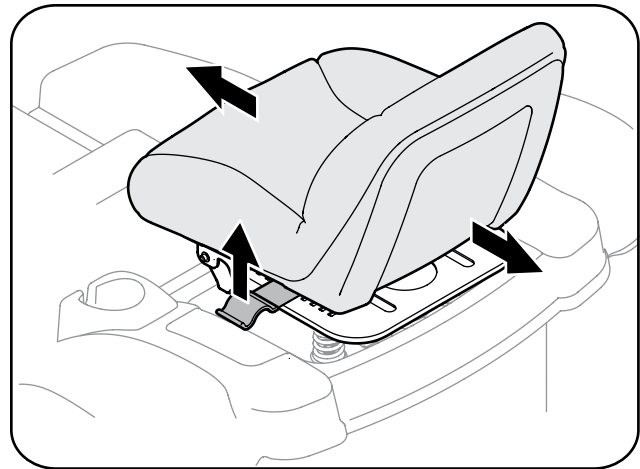

Figure 6-5

2. Slide the seat to the desired position. See Figure 6-5.
3. Once the desired position is reached, release the seat lever. Slide the seat slightly fore and aft as necessary to engage the seat lever into one of the eight adjustment positions in the index plate. Make certain the seat is locked in position.

Side to Side Leveling the Deck

NOTE: Check the tractor's tire pressure before performing any deck leveling adjustments. Refer to "Tires" earlier in this section for information regarding tire pressure.

If the cutting deck appears to be mowing unevenly, a side to side adjustment can be performed. Adjust if necessary as follows:

1. With the tractor parked on a firm, level surface, move the deck to the mid height position (third or fourth notch) using the deck lift lever. Rotate both outer blades so that they are perpendicular with the tractor frame.
2. Measure the distance from the outside of the left blade tip to the ground and the distance from the outside of the right blade tip to the ground. Both measurements taken should be equal. If they're not, note whether the left side of the deck is lower or higher and proceed to the next step.

- Working from the left side of the tractor, loosen, but do not remove, the hex cap screw on the left deck hanger bracket. Working from the left side of the tractor, loosen, but do not remove, the hex cap screw in the left deck adjustment bracket. See Figure 6-6.

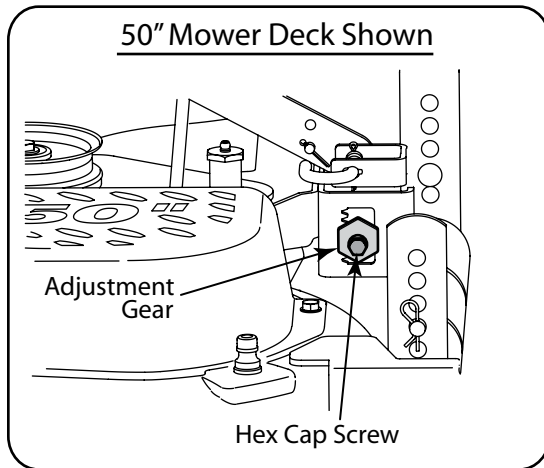

Figure 6-6

- To even the deck turn the adjustment gear, located immediately behind the hex cap screw, clockwise (rearward) to lower the left side of the deck. Turn the gear counter-clockwise (toward front) to raise the left side of the deck. See Figure 6-6.
- The deck is properly leveled when both blade tip measurements, as described earlier, are equal.
- Retighten the hex cap screw in the left deck adjustment bracket when proper adjustment is achieved.

Front To Rear Deck Leveling

The front of the cutting deck is supported by an adjustable front deck hanger rod. This rod can be adjusted to set the front to rear pitch of the deck. The front of the deck should be between 1/4-inch and 3/8-inch lower than the rear of the deck. Adjust if necessary as follows:

- With the tractor parked on a firm, level surface, move the deck to the mid height position (third or fourth notch) using the deck lift lever. Rotate the blade nearest the discharge chute so that it is parallel with the tractor frame.
- Measure the distance from the front of the blade tip to the ground and the rear of the blade tip to the ground. The front measurement taken should be between 1/4" and 3/8" less than the rear measurement. Determine the approximate distance necessary for proper adjustment and proceed, if necessary, to the next step.
- Working at the front of the tractor, loosen the two hex lock nuts at the front of the deck hanger rod. Thread the lock nuts away from the hex nuts behind them. Refer to Figure 6-7.

- Use a open end wrench to turn the inner hex nuts to adjust the front of the deck. Turn the hex nuts clockwise to raise the front of the deck, or counterclockwise to lower the front of the deck. Adjust the hex nuts evenly so that the deck hanger rod is at the front of both slots in the hanger bracket on the front of the deck. See Figure 6-7.

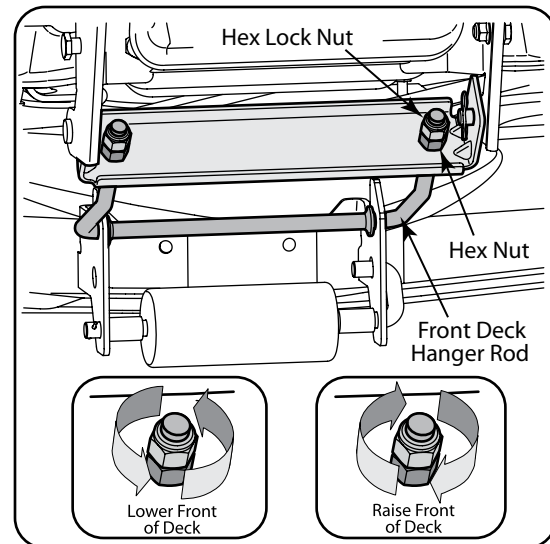

Figure 6-7

- Retighten the two hex lock nuts when properly adjusted.

Deck Gauge Wheel Adjustment

NOTE: The deck gauge wheels are an anti-scalp feature of the deck and are not designed to support the weight of the cutting deck.

The deck gauge wheels should neither contact the ground, nor be high off the ground, when the deck is moved to the desired height setting. If you change your cutting height during the mowing season, the gauge wheels should be checked and adjusted as necessary.

Adjust the gauge wheels as follows:

- Place the tractor on a smooth, flat surface and move the deck to the desired mowing height using the deck lift lever.
- Check gauge wheels distance from the flat surface below. If the gauge wheels contact the ground, they must be raised. If the gauge wheels are higher than 1/2" above the ground, they should be lowered.
- Remove the shoulder bolt securing one of the front ball wheels to the front index bracket. Reposition the ball wheel to align with the one of four index holes that places the wheel 1/4" to 1/2" above the ground. Secure the ball wheel to the index bracket with the shoulder bolt. Note the index hole used and secure the other ball wheel in the same position. See Figure 6-8.

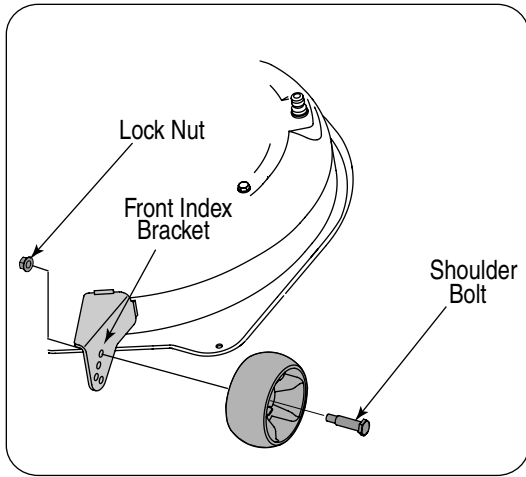

Figure 6-8

Deck Rear Roller Adjustment

The rear rollers on the mower deck are not designed to carry the weight of the deck. The rear rollers should be adjusted to approximately 1/4" to 1/2" above the ground when the deck is moved to the desired cutting height.

Place the tractor on a smooth, flat surface, move the deck to the desired cutting height, and check the height of the rear rollers. If contacting the ground, or above 1/2" from the ground, adjust the rear rollers as follows:

46" Deck ONLY

The 46" deck roller assembly index bracket has three adjustment positions using either the bottom two holes, middle two holes, or top two holes.

- Support the roller assembly and remove the two self tapping screws from both the left and right roller index brackets.
- Position the roller assembly so that the rollers are approximately 1/4" to 1/2" above the flat surface below. Align the nearest two index bracket holes with holes in the deck mounting brackets. See Figure 6-9.

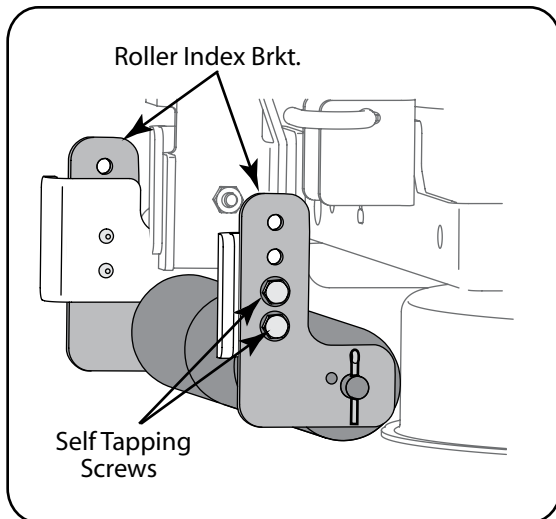

Figure 6-9

- Secure the roller assembly with the four self tapping screws. Refer to Figure 6-9.

NOTE: The self tapping screws should be in the corresponding holes of both the left and right roller index brackets.

50" Deck ONLY

The 50" deck roller assembly index bracket has five adjustment positions holes.

- While supporting the roller assembly, remove click pin and withdraw the clevis pin from both the left and right roller index brackets. See Figure 6-10.

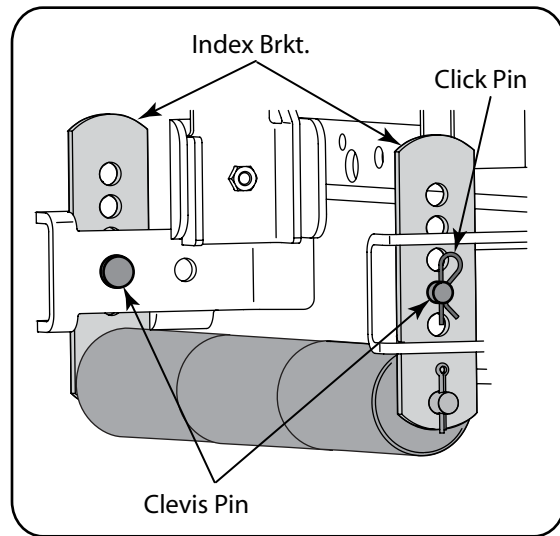

Figure 6-10

- Position the roller assembly so that the rollers are approximately 1/4" to 1/2" above the flat surface below.
- Align the nearest index bracket holes with the holes in the deck mounting brackets. Insert the clevis pins through the deck brackets and the index brackets and secure with the click pins. See Figure 6-10.

NOTE: The clevis pins should be in the corresponding holes of both the left and right roller index brackets.

Maintenance Schedule

	Before Each use	Every 10 Hours	Every 25 Hours	Every 50 Hours	Every 100 Hours	Prior to Storing
Clean Hood/Dash Louvers		✓				✓
Check Engine Oil Level	✓					
Check Air Filter for Dirty, Loose or Damaged Parts	✓					
Clean and Re-oil Air Filter's Foam Precleaner			✓			
Replace Air Filter Element					✓	
Change Engine Oil and Replace Oil Filter					✓	
Clean Battery Terminals		✓				✓
Lube Mid Steering Arms, Pivot Shafts, and Axles			✓			✓
Lube Front Wheel Bearings			✓			✓
Clean Engine Cooling Fins			✓			✓
Lube Front Deck Wheels			✓			✓
Lube Deck Spindles and Idler Bracket		✓				✓
Lube Pedal Pivot Points						✓
Check Spark Plug Condition & Gap					✓	✓
Replace Fuel Filter					✓	

Pivot Bar adjustment

If excessive play is experienced in the steering wheel, check the pivot bar for forward/rearward movement.

1. Raise the front of the tractor and set it on jack stands, so the front wheels are suspended above the ground.
2. Grasping the ends of the pivot bar, attempt to move each end of the axle forward and rearward to check for side play. There should be minimal or no side play.
3. If there is no side play, lower the tractor to the ground and have the steering linkage inspected by you Cub Cadet dealer. If there is side play, tighten the pivot bar as follows:
 - Support the pivot bar, then remove the hex lock nuts securing the two shoulder bolts that pass through the pivot bar bracket, the pivot bar, and frame. Refer to Figure 6-2.
 - Slide a half inch flat washer, with a maximum thickness of .030 inch, onto each shoulder bolt. Reinstall the shoulder bolts w/washers and fasten with the two hex lock nuts.
 - Gradually and evenly tighten the hex lock nut while continuing to check the forward/rearward movement of the pivot bar. Tighten the lock nuts until minimum play, without binding the pivot bar's up and down movement, is achieved.

Checking Main Harness Fuse

- A 20 amp fuse is installed in your tractor's wiring harness to protect the tractor's electrical system from damage caused by excessive amperage.
- If the electrical system does not function, or your tractor's engine will not crank, first check to be certain that the fuse has not blown.
- The fuse can be found inside of the dash panel behind the battery tray. You may need to remove the battery to gain access to the fuse. Always use a fuse with the same amperage capacity for replacement.
- A five amp fuse can also be found inside the dash panel. This fuse is for the 12 volt power outlet.

IMPORTANT: Always use a fuse with the same amperage capacity for replacement.

Battery

The battery is sealed and is maintenance-free. Acid levels cannot be checked.

- Always keep the battery cables and terminals clean and free of corrosive build-up.
- After cleaning the battery and terminals, apply a light coat of petroleum jelly or grease to both terminals.
- Always keep the rubber boot positioned over the positive terminal to prevent shorting.

IMPORTANT: If removing the battery for any reason, disconnect the NEGATIVE (Black) wire from its terminal FIRST, followed by the POSITIVE (Red) wire. When re-installing the battery, always connect the POSITIVE (Red) wire its terminal first, followed by the NEGATIVE (Black) wire. Be certain that the wires are connected to the correct terminals; reversing them could change the polarity and result in damage to your engine's alternating system.

Charging the Battery

If the tractor has not been put into use for an extended period of time, charge the battery with an automotive-type 12-volt charger for a minimum of one hour at six amps.



WARNING! Batteries give off an explosive gas while charging. Charge battery in a well ventilated area and keep away from an open flame or pilot light as on a water heater, space heater, furnace, clothes dryer or other gas appliances.

Cleaning the Battery

Clean the battery by removing it from the tractor and washing with a baking soda and water solution. If necessary, scrape the battery terminals with a wire brush to remove deposits. Coat terminals and exposed wiring with grease or petroleum jelly to prevent corrosion.

Battery Failures

Some common causes for battery failure are:

- incorrect initial activation
- undercharging
- overcharging
- corroded connections
- freezing

These failures are NOT covered by your tractor's warranty.

Changing Transmission Drive Belt

NOTE: Several components must be removed, including transmission steering linkage which will have to be readjusted, in order to change the tractor's transmission drive belt. Contact your Cub Cadet dealer to have your transmission drive belt replaced.

Hydrostatic Transmission

Keep the area around the transmission cooling fan free of grass and debris at all times. The hydrostatic transmission is sealed at the factory and is maintenance free. The fluid level cannot be checked and cannot be changed.

Jump Starting



WARNING! When removing or installing the battery, follow these instructions to prevent the screwdriver (or other metal tools) from shorting against the frame.

IMPORTANT: Never jump your tractor's dead battery with the battery of a running vehicle.

1. Connect end of one jumper cable to the positive terminal of the good battery, then the other end to the positive terminal of the dead battery.
2. Connect the other jumper cable to the negative terminal of the good battery, then to the **frame of the unit with the dead battery.**



WARNING!: Failure to use this procedure could cause sparking, and the gas in either battery could explode.

Cutting Deck Removal

To remove the cutting deck, proceed as follows:

1. Disengage the PTO (Blade Engage) and engage the parking brake.
2. Place the deck gauge wheels in their highest setting (lowest deck setting).
3. Lower the deck by moving the deck lift lever into the bottom notch on the right fender.
4. Looking at the cutting deck from the left side of the tractor, locate the deck support pin on the rear left side of the deck. Refer to Figure 7-1.
5. Pull the deck support pin outward to release the deck from the deck lift arm. Pivot the support pin handle downward to lock the pin in the disengaged position. Refer to Figure 7-1.

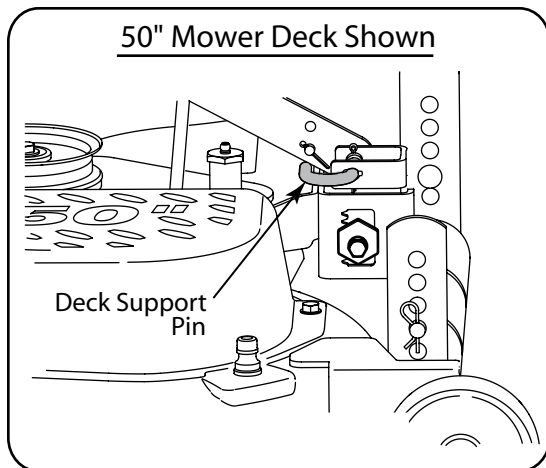

Figure 7-1

6. Move to the right side of the tractor and repeat the previous step to release the deck from the RH lift arm.
6. Move the deck lift lever into the top notch on the right fender to raise deck lift arms up and out of the way. Carefully slide the cutting deck forward and remove the deck belt from around the tractor's PTO pulley on the bottom of the engine.
9. Continue to roll the deck toward the front of the tractor until the front deck hanger rod can be removed from the slots of the hanger bracket at the front of the deck.

10. While holding the front deck hanger rod upward until it clears the hanger bracket on the front of the deck, carefully slide the deck out from the right side of the tractor.

Cutting Blades



WARNING: Be sure to shut the engine off, remove ignition key, disconnect the spark plug wire(s) to prevent unintended starting before removing the cutting blade(s) for sharpening or replacement. Protect your hands by using heavy gloves or a rag to grasp the cutting blade.



WARNING: Periodically inspect the blade spindles for cracks or damage, especially if you strike a foreign object. Replace immediately if damaged.

The blades may be removed as follows.

- Remove the deck from beneath the tractor, (refer to Cutting Deck Removal) then gently flip the deck over to expose its underside.

NOTE: A block of wood may be placed between the deck housing and the cutting edge of the blade to help in breaking loose the hex nut securing the blade.

- Use a 15/16" wrench to loosen the hex flange nut securing the blade to the bottom of the spindle assembly. Secure the spindle by either holding the blade tightly, or by using a second wrench to hold the nut at the top of the spindle.
- Continue holding the blade onto the star hub of the spindle, and remove the flange nut and cutting blade.
- Repeat the previous steps to remove the other blades.
- To properly sharpen the cutting blades, remove equal amounts of metal from both ends of the blades along the cutting edges, parallel to the trailing edge, at a 25° to 30° angle.

IMPORTANT: If the cutting edge of the blade has already been sharpened to within 1 5/8" from the edge, or if any metal separation is present, replace the blades with new ones. See Figure 7-2.

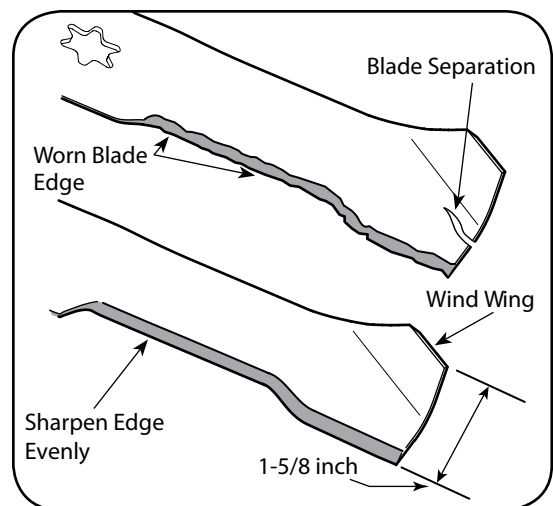

Figure 7-2

- It is important that each cutting blade edge be ground equally to maintain proper blade balance.
- A poorly balanced blade will cause excessive vibration and may cause damage to the tractor and result in personal injury. The blade can be tested by balancing it on a round shaft screwdriver. Grind metal from the heavy side until it balances evenly.

IMPORTANT: When replacing the blades, make certain the side of the blade marked "Bottom" faces the ground when the mower is turned to the operating position.

- Rotate the blade as necessary to align its star hole with the star of the spindle shaft, then slide the blade onto the spindle shaft. Thread the hex flange onto the spindle shaft and use a torque wrench to tighten the hex flange nut to 70 to 90 foot-pounds.
- Repeat the above procedure to install the other blades.

Changing the Deck Belt



WARNING: Be sure to shut the engine off, remove ignition key, disconnect the spark plug wire(s) to prevent unintended starting before removing the belt(s).



WARNING: Avoid the possibility of a pinching injury. Do not place your fingers on the idler spring or between the belt and a pulley while removing the belt.

All belts on your tractor are subject to wear and should be replaced if any signs of wear are present.

IMPORTANT: Do not use substitute belts. The V-belt found on your tractor is specially designed for optimal performance and service life for your deck application. Use only OEM original replacement belts.

To change or replace the deck belt on your tractor, proceed as follows:

- Remove the deck from beneath the tractor (refer to Cutting Deck Removal on page 24)
- Remove the spindle covers by removing the self-tapping screws that fasten them to the deck. See to Figure 7-3.

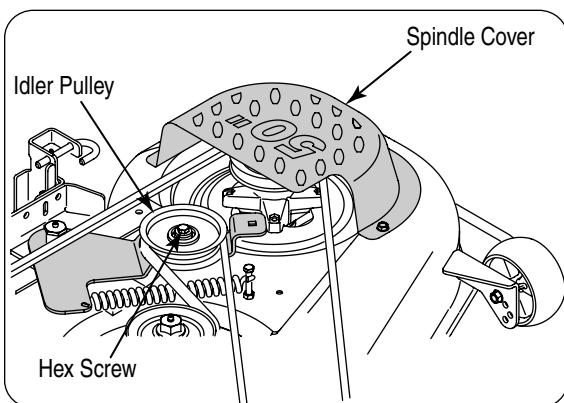

Figure 7-3

- **46" Mower Deck ONLY** - Remove the old belt from the deck. Install the new belt around the spindle and idler pulleys as shown in Figure 7-4.
- **50" Mower Deck ONLY**
 1. Loosen the hex screw fastening the idler pulley to the idler arm as necessary to slide the belt from between the idler pulley and idler arm. See Figure 7-3.
 2. Place the new belt between the idler pulley and idler arm. The backside of the 'V' belt should be against the idler pulley. Tighten the hex screw to secure the idler pulley.
 3. Route the deck belt around the spindle pulleys and idler pulleys as shown in Figure 7-5.
- Reinstall the spindle covers on the deck using the self-tapping screws. Do not overtighten the screws.

Reinstalling the Cutting Deck

There are two methods for reinstalling the mower deck on the tractor. One method involves rotating the deck idler arm to relieve enough belt tension to allow the belt to be placed in either the PTO pulley or the deck idler pulley. Because that method is difficult, we recommend using the second method of rolling the belt onto the PTO pulley.

Install the cutting deck as follows:

- From the right side of the tractor, slide the deck under the tractor and align the rear deck hanger bracket with the deck lift arms.
- Slide the deck forward and place the deck front hanger rod into the slots of the deck front hanger bracket. Then slide the deck rearward so that the hanger rod is at the front of the slots.
- Using the deck lift lever, lower the deck lift arms. From either side of the tractor, pull the support pin in the deck rear hanger bracket outward, align the deck lift arm hole with the deck support pin and release the pin so that it goes through the deck lift arm. Repeat on the other side of the tractor to secure the deck.
- After first making sure the deck belt is properly engaged in all of the deck pulleys, route the deck belt forward through the center of the front deck hanger rod and toward the PTO pulley on the bottom of the engine.
- Using the deck lift handle, raise the deck to the position that gives you the most horizontal run of the belt between the deck pulleys and the PTO pulley on the bottom of the engine.
- Sitting in front of the tractor, facing rearward, make certain the belt is not twisted; then reach beneath the tractor to grasp the belt and pull it toward the PTO pulley.

NOTE: References to left and right are from the front of the tractor in the following instructions.

- Pull the right side of the belt forward and place the narrow V side of the belt into the PTO pulley.
- While holding the belt and pulley together, rotate the pulley to the left. Continue holding and rotating the pulley and belt until the belt is fully rolled into the PTO pulley. Refer to Figure 7-6.



WARNING! Use caution to prevent pinching your fingers when rolling the belt onto the PTO pulley.

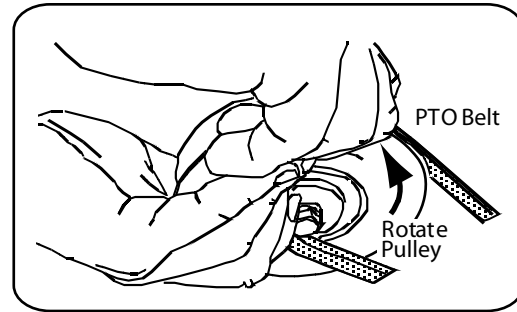

Figure 7-6

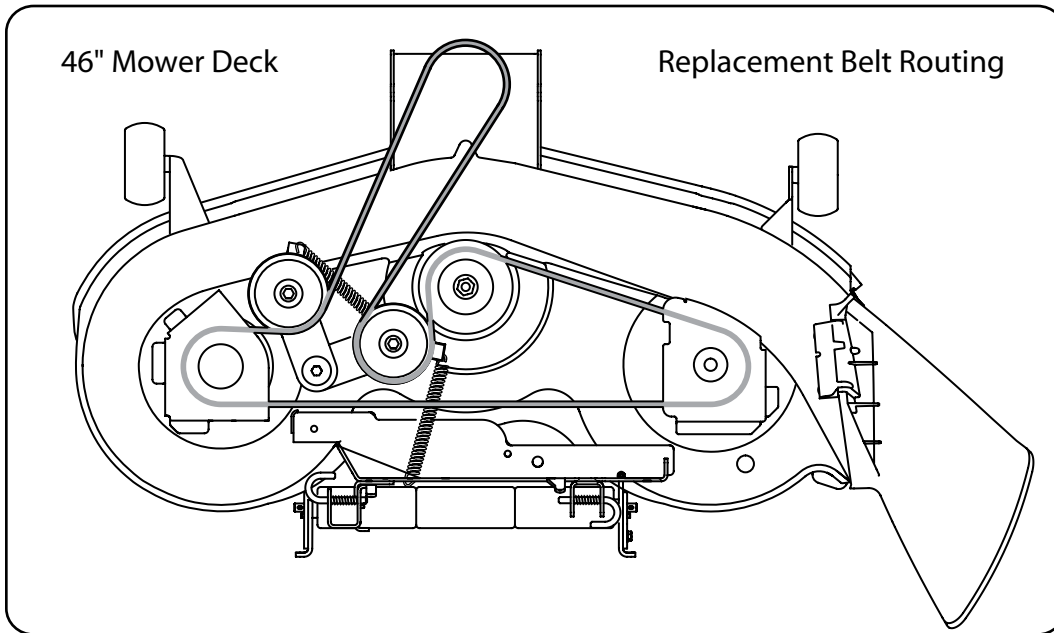

Figure 7-4 Replacement Belt Routing 46" Mower Deck

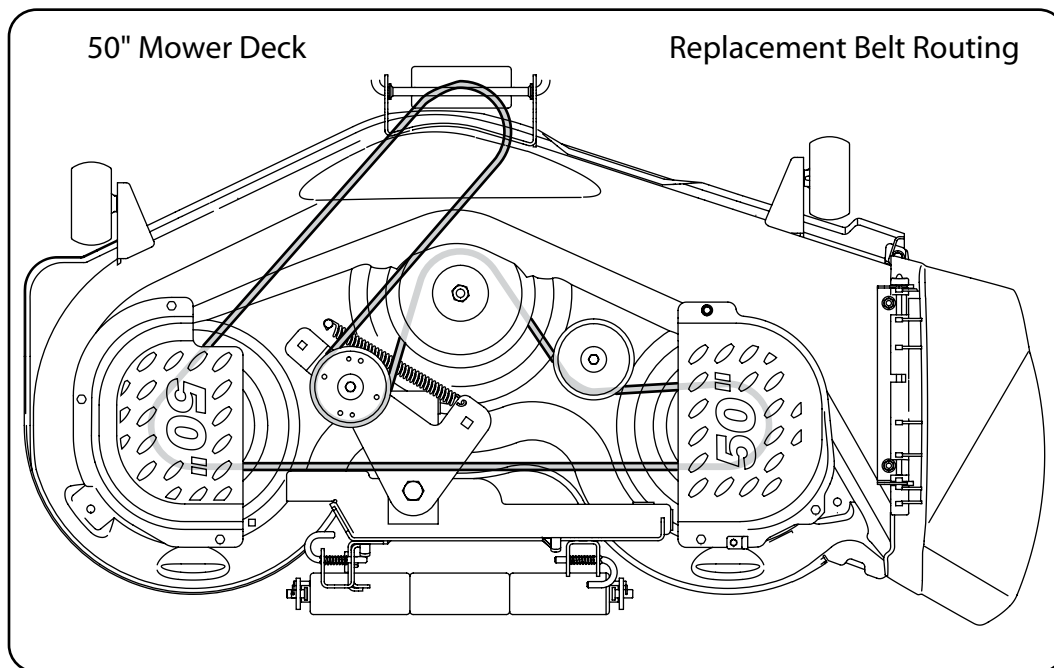

Figure 7-5 Replacement Belt Routing 50" Mower Deck

Off Season Storage

If the machine is to be inoperative for a period longer than 30 days, the following procedures are recommended:



WARNING: Never store the machine or fuel container indoors where there is an open flame, spark or pilot light such as on water heater, furnace, clothes dryer or other gas appliance.

IMPORTANT: Fuel left in the fuel tank during warm weather deteriorates and will cause serious starting problems.

To prevent gum deposits from forming inside the engine's carburetor and causing possible malfunction of the engine, the fuel system must be either completely emptied, or the gasoline must be treated with a stabilizer to prevent deterioration.

1. If using a fuel stabilizer:

- Read the product manufacturer's instructions and recommendations.
- Add to clean, fresh gasoline the correct amount of stabilizer for the capacity of the fuel system.
- Fill the fuel tank with treated fuel and run the engine for 2-3 minutes to get stabilized fuel into the carburetor.

2. If emptying the fuel system:

- Do not drain fuel when the engine is hot. Allow the engine adequate time to cool. Drain fuel into an approved container outdoors, away from open flame.
- Drain any large volume of fuel from the tank by disconnecting the fuel line from the in-line fuel filter near the engine.
- Reconnect the fuel line and run the engine until it starts to falter, then use the choke to keep the engine running until all fuel in the carburetor has been exhausted.
- Again disconnect the fuel line and drain any remaining gasoline from the system.



WARNING: Drain fuel only into an approved container outdoors, away from an open flame. Allow engine to cool. Extinguish cigarettes, cigars, pipes, and other sources of ignition prior to draining fuel.

Remove the spark plug and pour one (1) ounce of engine oil through the spark plug hole into the cylinder. Crank the engine several times to distribute the oil. Replace the spark plug.

Before storing for an extended period, clean and lubricate the tractor as instructed in "Maintenance and Adjustments."

Problem	Cause	Remedy
Engine fails to start	<ol style="list-style-type: none"> 1. PTO/Blade Engage knob engaged. 2. Parking brake not engaged. 3. Spark plug wire(s) disconnected. 4. Throttle control lever not in correct starting position. 5. Choke not activated 6. Fuel tank empty, or stale fuel. 7. Blocked fuel line. 8. Faulty spark plug(s). 9. Engine flooded. 	<ol style="list-style-type: none"> 1. Place knob in disengaged (OFF) position. 2. Engage parking brake. 3. Connect wire(s) to spark plug(s). 4. Place throttle lever to FAST position. 5. Pull the CHOKE control outward. 6. Fill tank with clean, fresh (less than 30 days old) gas. 7. Clean fuel line and replace fuel filter. 8. Clean, adjust gap or replace plug(s). 9. Crank engine with throttle in FAST position.
Engine runs erratic	<ol style="list-style-type: none"> 1. Unit running with CHOKE activated. 2. Spark plug wire(s) loose. 3. Blocked fuel line or stale fuel. 4. Vent in gas cap plugged. 5. Water or dirt in fuel system. 6. Dirty air cleaner. 	<ol style="list-style-type: none"> 1. Push CHOKE control in. 2. Connect spark plug wire(s). 3. Clean fuel line; fill tank with clean, fresh gasoline and replace fuel filter. 4. Clear vent or replace cap if damaged. 5. Drain fuel tank. Refill with clean, fresh gasoline. 6. Replace air cleaner paper element or clean foam pre-cleaner.
Engine overheats	<ol style="list-style-type: none"> 1. Engine oil level low. 2. Air flow restricted. 	<ol style="list-style-type: none"> 1. Fill crankcase with proper amount and weight of oil. 2. Clean grass clippings and debris from around the engine's cooling fins and blower housing.
Engine hesitates at high RPM	<ol style="list-style-type: none"> 1. Spark plug(s) gap too close. 	<ol style="list-style-type: none"> 1. Remove spark plug(s) and reset the gap.
Engine Idles rough	<ol style="list-style-type: none"> 1. Spark plug(s) fouled, faulty or gap too wide. 2. Dirty air cleaner. 	<ol style="list-style-type: none"> 1. Replace spark plug(s). Set plug gap. 2. Replace air cleaner element and/or clean pre-cleaner.
Excessive vibration	<ol style="list-style-type: none"> 1. Cutting blade loose or unbalanced. 2. Damaged or bent cutting blade. 	<ol style="list-style-type: none"> 1. Tighten blade and spindle. 2. Replace blade.
Mower will not mulch grass	<ol style="list-style-type: none"> 1. Engine speed too low. 2. Wet grass. 3. Excessively high grass. 4. Dull blade. 	<ol style="list-style-type: none"> 1. Place throttle in FAST (rabbit) position. 2. Do not mulch when grass is wet. 3. Mow once at a high cutting height, then mow again at desired height or make a narrower cutting swath. 4. Sharpen or replace blade.
Uneven cut	<ol style="list-style-type: none"> 1. Deck not leveled properly. 2. Dull blade. 3. Uneven tire pressure. 	<ol style="list-style-type: none"> 1. Perform side-to-side deck adjustment. 2. Sharpen or replace blade. 3. Check tire pressure in all four tires.

Replacement Parts

9

Contact your Cub Cadet dealer to order replacement parts. If you do not have a dealer, call the Customer Dealer Referral Line at 1-877-282-8684 or visit www.cubcadet.com to find the nearest Cub Cadet dealer in your area. Phone (800) 965-4CUB to order replacement parts or a complete Parts Manual (have your full model number and serial number ready). Parts Manual downloads are also available free of charge at www.cubcadet.com.

Description	Model i1046	Model i1050
Lower Drive Belt - Contact Dealer	954-04134	954-04134
Engine to Deck/ Deck Spindle Belt	754-04153	954-04077
Deck Blades - 46" Deck	942-04124 (Qty. 1)	942-04053C (Qty. 3)
	942-04125 (Qty. 2)	
Deck Spindle	618-0660 (Qty. 3)	618-04126A (Qty. 3)
Deck Front Ball Wheels	734-04155 (Qty. 2)	734-04155 (Qty. 2)
Deck Rollers	731-05679 (Qty. 3)	731-05679 (Qty. 4)
Battery	925-1707D	925-1707D
Starter Solenoid	725-04439	725-04439
Ignition Keys	725-2054	725-2054
Engine Oil Filter	KH-52-050-02-S	KH-52-050-02-S
Engine Oil (Capacity 57.6 ounces)	737-3030A (1qt.)	737-3030A (1qt.)
Engine Air Filter Element AND Foam Precleaner	KH-32-883-03-S1	KH-32-883-03-S1
Fuel Filter	KH-25-050-22-S	KH-25-050-22-S
Spark Plug	759-3336	759-3336
Deck Discharge Chute Assembly	931-1032B	631-04070A

The following attachments and accessories are available for the Model i1046 and/or i1050 Lawn Tractors. See the retailer from which you purchased your tractor, or an authorized Cub Cadet Dealer for information regarding price and availability.

MODEL	DESCRIPTION
19A-100-100	Twin Rear Bagger Grass Collector for 46" Deck
19A-101-100	Twin Rear Bagger Grass Collector for 50" Deck
190-833-000	46" Dozer Blade
19A-102-100	18 Cubic Foot Steel Cart
19A-106-100	10 Cubic Foot Poly Cart
19A-105-100	48" Broadcast Spreader
19A-103-100	42" Sweeper
19A-104-100	25 Gallon Sprayer
19A-107-100	48" Dethatcher
19A-113-100	48" Poly Roller
19A-108-100	48" Plug Aerator
19A-109-100	48" Spike Aerator

**CALIFORNIA EMISSION CONTROL WARRANTY STATEMENT
YOUR WARRANTY RIGHTS AND OBLIGATIONS**

The California Air Resources Board and MTD Consumer Group Inc are pleased to explain the evaporative emission control system warranty on your 2008 lawn mower. In California, new lawn mower must be designed, built and equipped to meet the State's stringent anti-smog standards. MTD Consumer Group Inc must warrant the EECS on your lawn mower for the period of time listed below provided there has been no abuse, neglect or improper maintenance of your lawn mower.

Your EECS may include parts such as the carburetor, fuel-injection system, the ignition system, catalytic converter, fuel tanks, fuel lines, fuel caps, valves, canisters, filters, vapor hoses, clamps, connectors, and other associated emission-related components.

Where a warrantable condition exists, MTD Consumer Group Inc will repair your lawn mower at no cost to you including diagnosis, parts and labor.

MANUFACTURER'S WARRANTY COVERAGE:

This evaporative emission control system is warranted for two years. If any evaporative emission-related part on your equipment is defective, the part will be repaired or replaced by MTD Consumer Group Inc.

OWNER'S WARRANTY RESPONSIBILITIES:

As the lawn mower owner, you are responsible for performance of the required maintenance listed in your owner's manual. MTD Consumer Group Inc recommends that you retain all receipts covering maintenance on your lawn mower, but MTD Consumer Group Inc cannot deny warranty solely for the lack of receipts.

As the lawn mower owner, you should however be aware that MTD Consumer Group Inc may deny you warranty coverage if your lawn mower or a part has failed due to abuse, neglect, or improper maintenance or unapproved modifications.

You are responsible for presenting your lawn mower to MTD Consumer Group Inc's distribution center or service center as soon as the problem exists. The warranty repairs should be completed in a reasonable amount of time, not to exceed 30 days. If you have a question regarding your warranty coverage, you should contact the MTD Consumer Group Inc Service Department at 1-800-800-7310.

GENERAL EMISSIONS WARRANTY COVERAGE:

MTD Consumer Group Inc warrants to the ultimate purchaser and each subsequent purchaser that the lawn mower is: Designed, built and equipped so as to conform with all applicable regulations; and free from defects in materials and workmanship that cause the failure of a warranted part to be identical in all material respects to that part as described in MTD Consumer Group Inc's application for certification.

The warranty period begins on the date the lawn mower is delivered to an ultimate purchaser or first placed into service. The warranty period is two years.

Subject to certain conditions and exclusions as stated below, the warranty on emission-related parts is as follows:

1. Any warranted part that is not scheduled for replacement as required maintenance in the written instructions supplied, is warranted for the warranty period stated above. If the part fails during the period of warranty coverage, the part will be repaired or replaced by MTD Consumer Group Inc according to subsection (4) below. Any such part repaired or replaced under warranty will be warranted for the remainder of the period.
2. Any warranted part that is scheduled only for regular inspection in the written instructions supplied is warranted for the warranty period stated above. Any such part repaired or replaced under warranty will be warranted for the remaining warranty period.
3. Any warranted part that is scheduled for replacement as required maintenance in the written instructions supplied is warranted for the period of time before the first scheduled replacement date for that part. If the part fails before the first scheduled replacement, the part will be repaired or replaced by MTD Consumer Group Inc according to subsection (4) below. Any such part repaired or replaced under warranty will be warranted for the remainder of the period prior to the first scheduled replacement point for the part.
4. Repair or replacement of any warranted part under the warranty provisions herein must be performed at a warranty station at no charge to the owner.
5. Notwithstanding the provisions herein, warranty services or repairs will be provided at all of our distribution centers that are franchised to service the subject engines or equipment.
6. The lawn mower owner will not be charged for diagnostic labor that is directly associated with diagnosis of a defective, emission-related warranted part, provided that such diagnostic work is performed at a warranty station.
7. MTD Consumer Group Inc is liable for damages to other engine or equipment components proximately caused by a failure under warranty of any warranted part.
8. Throughout the lawn mower warranty period stated above, MTD Consumer Group Inc will maintain a supply of warranted parts sufficient to meet the expected demand for such parts.
9. Any replacement part may be used in the performance of any warranty maintenance or repairs and must be provided without charge to the owner. Such use will not reduce the warranty obligations of MTD Consumer Group Inc.
10. Add-on or modified parts that are not exempted by the Air Resources Board may not be used. The use of any non-exempted add-on or modified parts by the ultimate purchaser will be grounds for disallowing a warranty claims. MTD Consumer Group Inc will not be liable to warrant failures of warranted parts caused by the use of a non-exempted add-on or modified part.

WARRANTED PARTS:

The repair or replacement of any warranted part otherwise eligible for warranty coverage may be excluded from such warranty coverage if MTD Consumer Group Inc demonstrates that the lawn mower has been abused, neglected, or improperly maintained, and that such abuse, neglect, or improper maintenance was the direct cause of the need for repair or replacement of the part. That notwithstanding, any adjustment of a component that has a factory installed, and properly operating, adjustment limiting device is still eligible for warranty coverage. The following emission warranty parts list are covered: Fuel Line, Fuel Line Clamps

CUB CADET LLC
MANUFACTURER'S LIMITED WARRANTY FOR
SERIES 1000 & SERIES 1500 TRACTORS

IMPORTANT: To obtain warranty coverage owner must present an original proof of purchase and applicable maintenance records to the servicing dealer. Please see the operator's manual for information on required maintenance and service intervals.

The limited warranty set forth below is given by Cub Cadet LLC with respect to new merchandise purchased or leased and used in the United States and/or its territories and possessions, and by MTD Products Limited with respect to new merchandise purchased or leased and used in Canada and/or its territories and possessions (either entity respectively, "Cub Cadet").

Cub Cadet warrants this product (excluding its *Normal Wear Parts, Batteries, Frame and Front Axle and Attachments* as described below) against defects in material and workmanship for a period of three (3) years or one hundred twenty (120) operation hours, whichever comes first, commencing on the date of original retail purchase or lease and will, at its option, repair or replace, free of charge, any part found to be defective in materials or workmanship.

Normal Wear Parts are warranted to be free from defects in material and workmanship for a period of thirty (30) days from the date of original purchase or lease. Normal wear parts include, but are not limited to items such as: belts, blades, blade adapters, grass bags, rider deck wheels, seats, and tires.

Batteries have a one-year prorated limited warranty against defects in material and workmanship, with 100% replacement during the first three months. After three months, the battery replacement credit is based on the months remaining in the twelve (12) month period dating back to the original date of original sale or lease. Any replacement battery will be warranted only for the remainder of the original warranty period.

Frame and Front Axle — Cub Cadet warrants the frame, and front cast iron pivot axle against defects in material and workmanship for a period of five (5) years or 500 hours, whichever occurs first, commencing on the date of original purchase or lease.

Attachments — Cub Cadet warrants attachments for this product against defects in material and workmanship for a period of two (2) years, commencing on the date of the attachment's original purchase or lease. Attachments include, but are not limited to items such as: grass collectors and mulch kits.

This limited warranty shall only apply if this product has been operated and maintained in accordance with the Operator's Manual furnished with the product, and has not been subject to misuse, abuse, neglect, accident, improper maintenance, alteration, vandalism, theft, fire, water, or damage because of other peril or natural disaster. Damage resulting from the installation or use of any part, accessory or attachment not approved by Cub Cadet for use with the product(s) covered by this manual will void your warranty as to any resulting damage. In addition, Cub Cadet may deny warranty coverage if the hour meter, or any part thereof, is altered, modified, disconnected or otherwise tampered with.

HOW TO OBTAIN SERVICE: Warranty service is available, WITH PROOF OF PURCHASE AND APPLICABLE MAINTENANCE RECORDS, through your local authorized service dealer. To locate the dealer in your area:

In the U.S.A.:

Check your Yellow Pages, or contact Cub Cadet LLC at P.O. Box 361131, Cleveland, Ohio 44136-0019, call 1-877-282-8684 or log on to our website at www.cubcadet.com.

In Canada:

Contact MTD Products Limited, Kitchener, ON N2G 4J1, call 1-800-668-1238 or log on to our website at www.mtdcanada.com.

Without limiting the foregoing, this limited warranty does not provide coverage in the following cases:

- a. Routine maintenance items such as lubricants, filters, blade sharpening, tune-ups, brake adjustments, clutch adjustments, deck adjustments, and normal deterioration of the exterior finish due to use or exposure.
- b. Service completed by someone other than an authorized service dealer.
- c. Cub Cadet does not extend any warranty for products sold or exported outside of the United States and/or Canada, and their respective possessions and territories, except those sold through Cub Cadet's authorized channels of export distribution.
- d. Replacement parts and/or accessories that are not genuine Cub Cadet parts.
- e. Transportation charges and service calls.

There are no implied warranties, including without limitation any implied warranty of merchantability or fitness for a particular purpose. No warranties shall apply after the applicable period of express written warranty above. No other express warranties beyond those mentioned above, given by any person or entity, including a dealer or retailer, with respect to any product, shall bind Cub Cadet. The exclusive remedy is repair or replacement of the product as set forth above. The terms of this warranty provide the sole and exclusive remedy arising from the sale and/or lease of the products covered hereby. Cub Cadet shall not be liable for any incidental or consequential loss or damage including, without limitation, expenses incurred for substitute or replacement lawn care services or for rental expenses to temporarily replace a warranted product.

Some jurisdictions do not allow the exclusion or limitation of incidental or consequential damages, or limitations on how long an implied warranty lasts, so the above exclusions or limitations may not apply to you.

In no event shall recovery of any kind be greater than the amount of the purchase price of the product sold. **Alteration of safety features of the product shall void this warranty.** You assume the risk and liability for loss, damage, or injury to you and your property and/or to others and their property arising out of the misuse or inability to use the product.

This limited warranty shall not extend to anyone other than the original purchaser or to the person for whom it was purchased as a gift.

HOW LOCAL LAWS RELATE TO THIS WARRANTY: This limited warranty gives you specific legal rights, and you may also have other rights that vary in different jurisdictions.

Cub Cadet LLC, P.O. BOX 361131 CLEVELAND, OHIO 44136-0019, Phone: 1-877-282-8684
MTD Products Limited, Kitchener, ON N2G 4J1, Phone: 1-800-668-1238