

# *Cub Cadet*<sup>®</sup>

## OPERATOR'S MANUAL

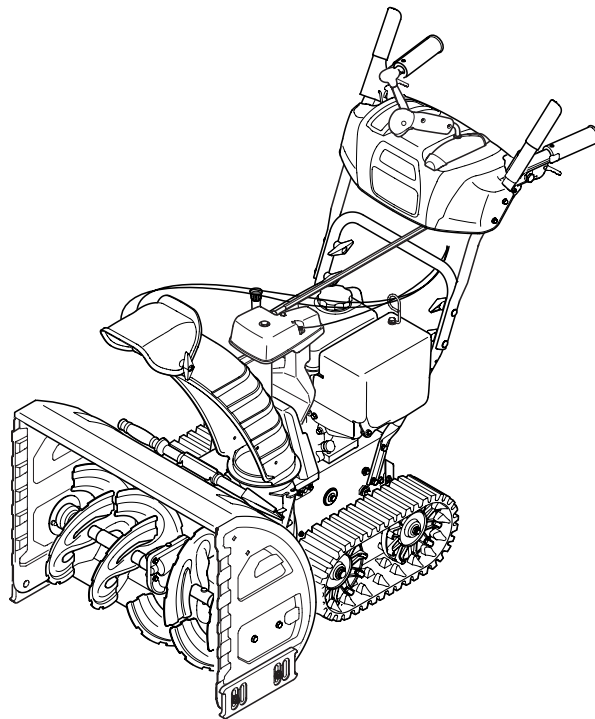

### Track Drive Snow Thrower — 726 TDE

**⚠ WARNING**

**READ AND FOLLOW ALL SAFETY RULES AND INSTRUCTIONS IN THIS MANUAL  
BEFORE ATTEMPTING TO OPERATE THIS MACHINE.  
FAILURE TO COMPLY WITH THESE INSTRUCTIONS MAY RESULT IN PERSONAL INJURY.**

---

CUB CADET LLC, P.O. BOX 361131 CLEVELAND, OHIO 44136-0019

---

## Thank You

Thank you for purchasing a Cub Cadet Snow Thrower. It was carefully engineered to provide excellent performance when properly operated and maintained.

Please read this entire manual prior to operating the equipment. It instructs you how to safely and easily set up, operate and maintain your machine. Please be sure that you, and any other persons who will operate the machine, carefully follow the recommended safety practices at all times. Failure to do so could result in personal injury or property damage.

All information in this manual is relative to the most recent product information available at the time of printing. Review this manual frequently to familiarize yourself with the machine, its features and operation. Please be aware that this Operator's Manual may cover a range of product specifications for various models. Characteristics and features discussed and/or illustrated in this manual may not be applicable to all models. We reserve the right to change product specifications, designs and equipment without notice and without incurring obligation.

If you have any problems or questions concerning the machine, phone your local Cub Cadet dealer or contact us directly. Cub Cadet's Customer Support telephone numbers, website address and mailing address can be found on this page. We want to ensure your complete satisfaction at all times.

Throughout this manual, all references to *right* and *left* side of the machine are observed from the operating position.

## Table of Contents

<b>Safe Operation Practices .....</b>	<b>3</b>	<b>Service .....</b>	<b>19</b>
<b>Assembly &amp; Set-Up .....</b>	<b>7</b>	<b>Troubleshooting .....</b>	<b>23</b>
<b>Controls .....</b>	<b>12</b>	<b>Replacement Parts .....</b>	<b>24</b>
<b>Operation .....</b>	<b>15</b>	<b>Attachments .....</b>	<b>25</b>
<b>Maintenance &amp; Adjustment .....</b>	<b>16</b>	<b>Warranty .....</b>	<b>Back Cover</b>

## Record Product Information

Before setting up and operating your new equipment, please locate the model plate on the equipment and record the information in the provided area to the right. You can locate the model plate by standing at the operator's position and looking down at the rear of the frame. This information will be necessary, should you seek technical support via our web site, Customer Support Department, or with a local authorized service dealer.

### MODEL NUMBER

--	--	--	--	--	--	--	--	--	--	--	--

### SERIAL NUMBER

--	--	--	--	--	--	--	--	--	--	--	--

## Customer Support

If you have difficulty assembling this product or have any questions regarding the controls, operation, or maintenance of this machine, you can seek help from the experts. Choose from the options below:

- ◇ Visit us on the web at [www.cubcadet.com](http://www.cubcadet.com)
- ◇ Locate your nearest Cub Cadet Dealer at (877) 282-8684
- ◇ Write to Cub Cadet LLC • P.O. Box 361131 • Cleveland, OH • 44136-0019



**WARNING!** This symbol points out important safety instructions which, if not followed, could endanger the personal safety and/or property of yourself and others. Read and follow all instructions in this manual before attempting to operate this machine. Failure to comply with these instructions may result in personal injury. When you see this symbol. **HEED ITS WARNING!**

## CALIFORNIA PROPOSITION 65



**WARNING!** Engine Exhaust, some of its constituents, and certain vehicle components contain or emit chemicals known to State of California to cause cancer and birth defects or other reproductive harm.



**DANGER:** This machine was built to be operated according to the safe operation practices in this manual. As with any type of power equipment, carelessness or error on the part of the operator can result in serious injury. This machine is capable of amputating fingers, hands, toes and feet and throwing foreign objects. Failure to observe the following safety instructions could result in serious injury or death.

### Training

1. Read, understand, and follow all instructions on the machine and in the manual(s) before attempting to assemble and operate. Keep this manual in a safe place for future and regular reference and for ordering replacement parts.
2. Be familiar with all controls and their proper operation. Know how to stop the machine and disengage them quickly.
3. Never allow children under 14 years of age to operate this machine. Children 14 and over should read and understand the instructions and safe operation practices in this manual and on the machine and be trained and supervised by an adult.
4. Never allow adults to operate this machine without proper instruction.
5. Thrown objects can cause serious personal injury. Plan your snow-throwing pattern to avoid discharge of material toward roads, bystanders and the like.
6. Keep bystanders, pets and children at least 75 feet from the machine while it is in operation. Stop machine if anyone enters the area.
7. Exercise caution to avoid slipping or falling, especially when operating in reverse.

### Preparation

Thoroughly inspect the area where the equipment is to be used. Remove all doormats, newspapers, sleds, boards, wires and other foreign objects, which could be tripped over or thrown by the auger/impeller.

1. Always wear safety glasses or eye shields during operation and while performing an adjustment or repair to protect your eyes. Thrown objects which ricochet can cause serious injury to the eyes.
2. Do not operate without wearing adequate winter outer garments. Do not wear jewelry, long scarves or other loose clothing, which could become entangled in moving parts. Wear footwear which will improve footing on slippery surfaces.
3. Use a grounded three-wire extension cord and receptacle for all machines with electric start engines.
4. Adjust auger housing height to clear gravel or crushed rock surfaces.
5. Disengage all control levers before starting the engine.
6. Never attempt to make any adjustments while engine is running, except where specifically recommended in the operator's manual.
7. Let engine and machine adjust to outdoor temperature before starting to clear snow.

## Safe Handling of Gasoline

To avoid personal injury or property damage use extreme care in handling gasoline. Gasoline is extremely flammable and the vapors are explosive. Serious personal injury can occur when gasoline is spilled on yourself or your clothes which can ignite. Wash your skin and change clothes immediately.

- a. Use only an approved gasoline container.
- b. Extinguish all cigarettes, cigars, pipes and other sources of ignition.
- c. Never fuel machine indoors.
- d. Never remove gas cap or add fuel while the engine is hot or running.
- e. Allow engine to cool at least two minutes before refueling.
- f. Never over fill fuel tank. Fill tank to no more than ½ inch below bottom of filler neck to provide space for fuel expansion.
- g. Replace gasoline cap and tighten securely.
- h. If gasoline is spilled, wipe it off the engine and equipment. Move machine to another area. Wait 5 minutes before starting the engine.
- i. Never store the machine or fuel container inside where there is an open flame, spark or pilot light (e.g. furnace, water heater, space heater, clothes dryer etc.).
- j. Allow machine to cool at least 5 minutes before storing.
- k. Never fill containers inside a vehicle or on a truck or trailer bed with a plastic liner. Always place containers on the ground away from your vehicle before filling.
- l. If possible, remove gas-powered equipment from the truck or trailer and refuel it on the ground. If this is not possible, then refuel such equipment on a trailer with a portable container, rather than from a gasoline dispenser nozzle.
- m. Keep the nozzle in contact with the rim of the fuel tank or container opening at all times until fueling is complete. Do not use a nozzle lock-open device.

## Operation

1. Do not put hands or feet near rotating parts, in the auger/impeller housing or chute assembly. Contact with the rotating parts can amputate hands and feet.
2. The auger/impeller control lever is a safety device. Never bypass its operation. Doing so makes the machine unsafe and may cause personal injury.
3. The control levers must operate easily in both directions and automatically return to the disengaged position when released.
4. Never operate with a missing or damaged chute assembly. Keep all safety devices in place and working.
5. Never run an engine indoors or in a poorly ventilated area. Engine exhaust contains carbon monoxide, an odorless and deadly gas.
6. Do not operate machine while under the influence of alcohol or drugs.
7. Muffler and engine become hot and can cause a burn. Do not touch. Keep children away.
8. Exercise extreme caution when operating on or crossing gravel surfaces. Stay alert for hidden hazards or traffic.
9. Exercise caution when changing direction and while operating on slopes.
10. Plan your snow-throwing pattern to avoid discharge towards windows, walls, cars etc. Thus, avoiding possible property damage or personal injury caused by a ricochet.
11. Never direct discharge at children, bystanders and pets or allow anyone in front of the machine.
12. Do not overload machine capacity by attempting to clear snow at too fast of a rate.
13. Never operate this machine without good visibility or light. Always be sure of your footing and keep a firm hold on the handles. Walk, never run.
14. Disengage power to the auger/impeller when transporting or not in use.
15. Never operate machine at high transport speeds on slippery surfaces. Look down and behind and use care when backing up.
16. If the machine should start to vibrate abnormally, stop the engine, disconnect the spark plug wire and ground it against the engine. Inspect thoroughly for damage. Repair any damage before starting and operating.
17. Disengage all control levers and stop engine before you leave the operating position (behind the handles). Wait until the auger/impeller comes to a complete stop before unlogging the chute assembly, making any adjustments, or inspections.
18. Never put your hand in the discharge or collector openings. Always use the clean-out tool provided to unlog the discharge opening. Do not unlog chute assembly while engine is running. Shut off engine and remain behind handles until all moving parts have stopped before unlogging.
19. Use only attachments and accessories approved by the manufacturer (e.g. wheel weights, tire chains, cabs etc.).
20. When starting engine, pull cord slowly until resistance is felt, then pull rapidly. Rapid retraction of starter cord (kickback) will pull hand and arm toward engine faster than you can let go. Broken bones, fractures, bruises or sprains could result.
21. If situations occur which are not covered in this manual, use care and good judgment. Contact Customer Support for assistance and the name of your nearest servicing dealer.

## Clearing a Clogged Discharge Chute

Hand contact with the rotating impeller inside the discharge chute is the most common cause of injury associated with snow throwers. Never use your hand to clean out the discharge chute.

To clear the chute:

1. SHUT THE ENGINE OFF!
2. Wait 10 seconds to be sure the impeller blades have stopped rotating.
3. Always use a clean-out tool, not your hands.

## Maintenance & Storage

1. Never tamper with safety devices. Check their proper operation regularly. Refer to the maintenance and adjustment sections of this manual.
2. Before cleaning, repairing, or inspecting machine disengage all control levers and stop the engine. Wait until the auger/impeller come to a complete stop. Disconnect the spark plug wire and ground against the engine to prevent unintended starting.
3. Check bolts and screws for proper tightness at frequent intervals to keep the machine in safe working condition. Also, visually inspect machine for any damage.
4. Do not change the engine governor setting or over-speed the engine. The governor controls the maximum safe operating speed of the engine.
5. Snow thrower shave plates and skid shoes are subject to wear and damage. For your safety protection, frequently check all components and replace with original equipment manufacturer's (OEM) parts only. "Use of parts which do not meet the original equipment specifications may lead to improper performance and compromise safety!"
6. Check control levers periodically to verify they engage and disengage properly and adjust, if necessary. Refer to the adjustment section in this operator's manual for instructions.
7. Maintain or replace safety and instruction labels, as necessary.
8. Observe proper disposal laws and regulations for gas, oil, etc. to protect the environment.
9. Prior to storing, run machine a few minutes to clear snow from machine and prevent freeze up of auger/impeller.
10. Never store the machine or fuel container inside where there is an open flame, spark or pilot light such as a water heater, furnace, clothes dryer etc.
11. Always refer to the operator's manual for proper instructions on off-season storage.
12. Check fuel line, tank, cap, and fittings frequently for cracks or leaks. Replace if necessary.
13. Do not crank engine with spark plug removed.

14. According to the Consumer Products Safety Commission (CPSC) and the U.S. Environmental Protection Agency (EPA), this product has an *Average Useful Life* of seven (7) years, or 60 hours of operation. At the end of the *Average Useful Life* have the machine inspected annually by an authorized service dealer to ensure that all mechanical and safety systems are working properly and not worn excessively. Failure to do so can result in accidents, injuries or death.

## Do not modify engine

To avoid serious injury or death, do not modify engine in any way. Tampering with the governor setting can lead to a runaway engine and cause it to operate at unsafe speeds. Never tamper with factory setting of engine governor.

## Notice Regarding Emissions

Engines which are certified to comply with California and federal EPA emission regulations for SORE (Small Off Road Equipment) are certified to operate on regular unleaded gasoline, and may include the following emission control systems: Engine Modification (EM), Oxidizing Catalyst (OC), Secondary Air Injection (SAI) and Three Way Catalyst (TWC) if so equipped.

## Spark Arrestor











**WARNING!** This machine is equipped with an internal combustion engine and should not be used on or near any unimproved forest-covered, brush covered or grass-covered land unless the engine's exhaust system is equipped with a spark arrester meeting applicable local or state laws (if any).

If a spark arrester is used, it should be maintained in effective working order by the operator. In the State of California the above is required by law (Section 4442 of the California Public Resources Code). Other states may have similar laws. Federal laws apply on federal lands.

A spark arrester for the muffler is available through your nearest engine authorized service dealer or contact the service department, P.O. Box 361131 Cleveland, Ohio 44136-0019.

## Safety Symbols

This page depicts and describes safety symbols that may appear on this product. Read, understand, and follow all instructions on the machine before attempting to assemble and operate.

Symbol	Description
	<b>READ THE OPERATOR'S MANUAL(S)</b> Read, understand, and follow all instructions in the manual(s) before attempting to assemble and operate
	<b>WARNING— ROTATING BLADES</b> Keep hands out of inlet and discharge openings while machine is running. There are rotating blades inside
	<b>WARNING— ROTATING BLADES</b> Keep hands out of inlet and discharge openings while machine is running. There are rotating blades inside
	<b>WARNING— ROTATING AUGER</b> Do not put hands or feet near rotating parts, in the auger/impeller housing or chute assembly. Contact with the rotating parts can amputate hands and feet.
	<b>WARNING—THROWN OBJECTS</b> This machine may pick up and throw objects which can cause serious personal injury.
	<b>WARNING—GASOLINE IS FLAMMABLE</b> Allow the engine to cool at least two minutes before refueling.
	<b>WARNING— CARBON MONOXIDE</b> Never run an engine indoors or in a poorly ventilated area. Engine exhaust contains carbon monoxide, an odorless and deadly gas.
	<b>WARNING— ELECTRICAL SHOCK</b> Do not use the engine's electric starter in the rain
	<b>WARNING— HOT SURFACE</b> Engine parts, especially the muffler, become extremely hot during operation. Allow engine and muffler to cool before touching.



**WARNING!** Your Responsibility—Restrict the use of this power machine to persons who read, understand and follow the warnings and instructions in this manual and on the machine.

**SAVE THESE INSTRUCTIONS!**

## Contents of Crate

- One Snow Thrower
- One Snow Thrower Operator's Manual
- Two Replacement Auger Shear Pins
- One Product Registration Card
- One Chute Assembly
- One Hex Rod

## Assembly

### Handle

1. Place the shift lever in the Forward-6 position
2. Remove the lower plastic wing nut and carriage bolt from each side of the upper handle; then raise the upper handle assembly until it snaps over the lower handle. See Fig. 3-1.

**NOTE:** Make certain the upper ends of each cable are seated properly in the proper brackets. See Figure 3-2.

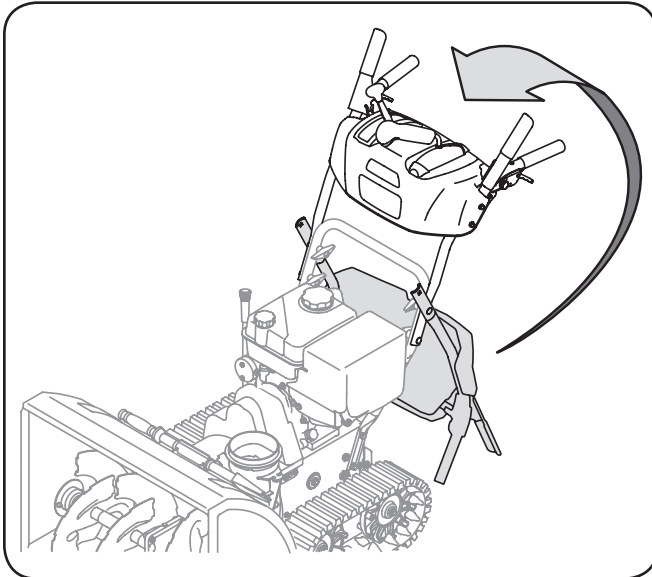

Figure 3-1

3. Looking beneath the handle panel, check that all of the cables (steering, auger, shift, and drive) are properly routed and not pinched or kinked.
4. Secure the handle by tightening the plastic knob located on both the left and right sides of the handle. Remove and discard any rubber bands, if present. They are for packaging purposes only.

### Chute Assembly

1. Remove cotter pin, wing nut and hex screw from chute control head. Remove clevis pin and bow-tie cotter pin from chute support bracket. See Fig. 3-3.

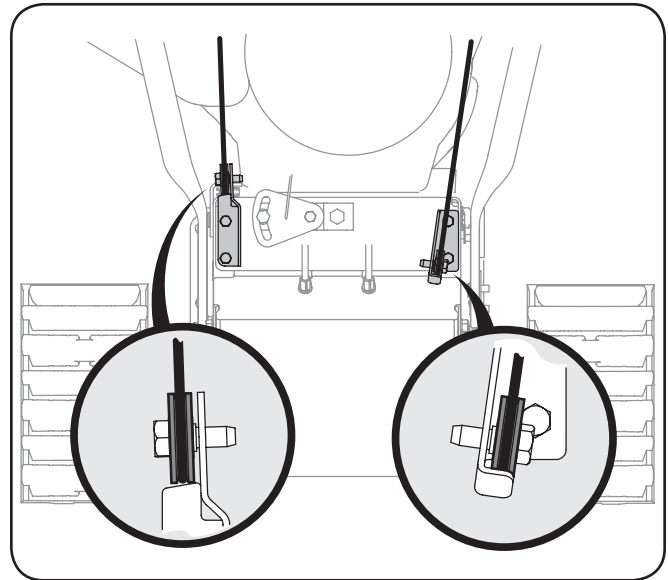

Figure 3-2

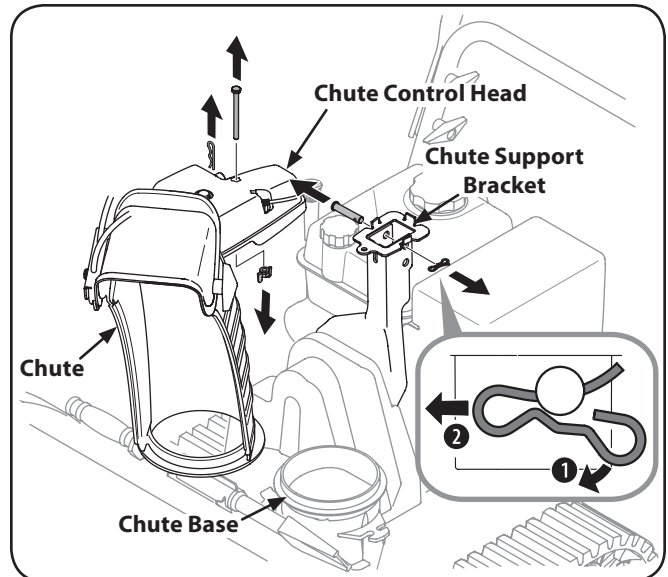
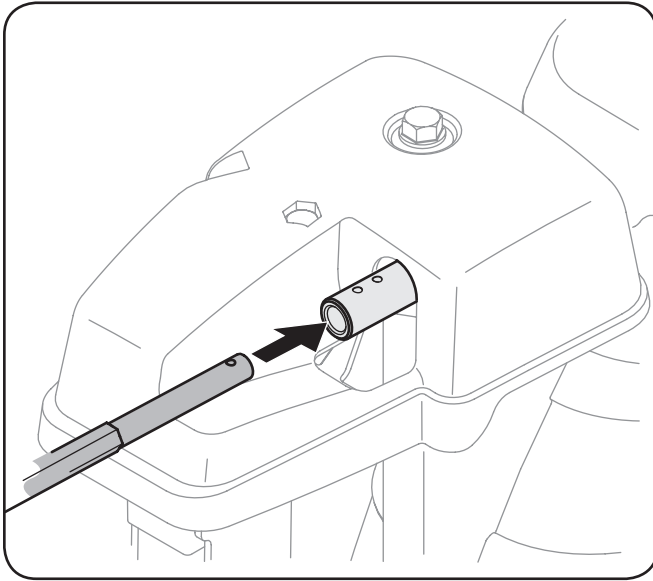

Figure 3-3

2. Insert hex rod into chute control head. Push rod as far into chute control head as possible, keeping the holes in the hex rod pointing upward. See Fig. 3-4.



**Figure 3-4**

3. Place chute onto chute base and ensure hex rod is positioned under the handle panel. Install hex bolt previously removed but do not secure with wing nut at this time. See Fig. 3-5.

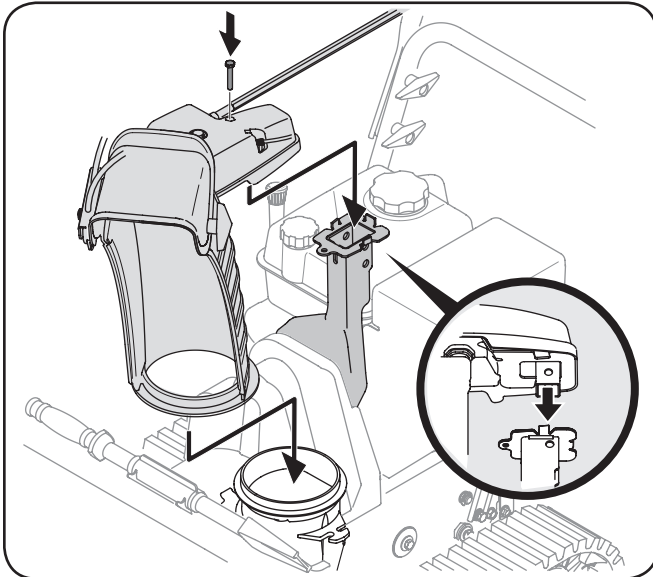

**Figure 3-5**

4. Squeeze the trigger on the joystick and rotate the chute by hand to face forward. The holes in the chute control input will be facing up. See Fig. 3-6.

**NOTE:** The chute will not rotate without squeezing the trigger on the joystick.

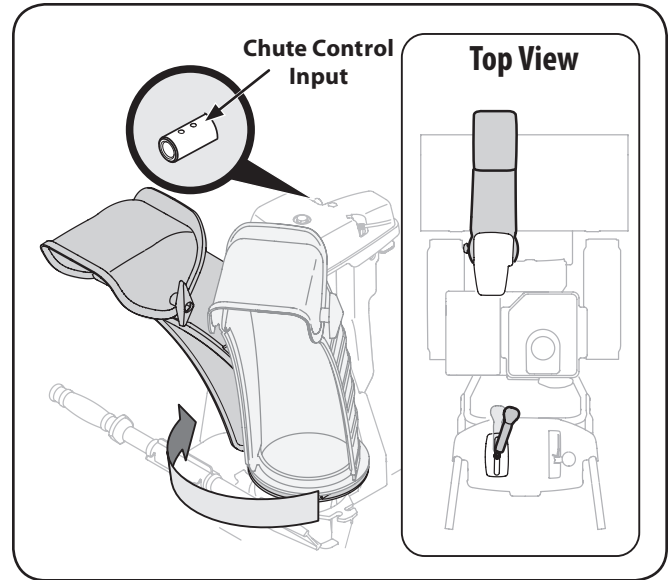

**Figure 3-6**

5. Rotate the joystick to the one o'clock position so that the silver indicator arrow on the pinion gear below the control panel faces upward. See Fig. 3-7.

**NOTE:** The joystick will be angled slightly to the right at the one o'clock position. See "Top View" in Fig. 3-6.

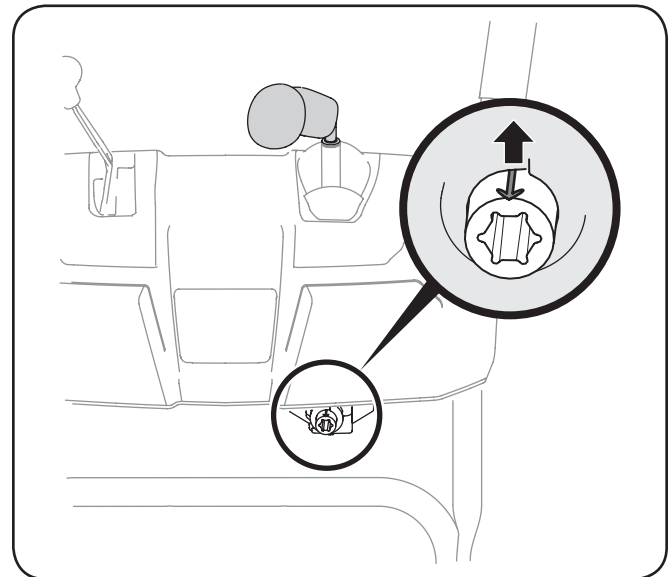

**Figure 3-7**

6. Insert the hex rod into the pinion gear below the joystick. Make sure to line up the hole in the hex rod with the arrow on the pinion gear. See Fig. 3-8.

**NOTE:** The hex rod will fit snugly into the pinion gear. Support the rear of the dash panel with one hand while inserting the hex rod with your other hand to ensure the hex rod is inserted **all the way** into the pinion gear.

**NOTE:** The hole is a reference for aligning the rod with the indicator arrow on the pinion gear, and will be visible after the rod has been inserted.

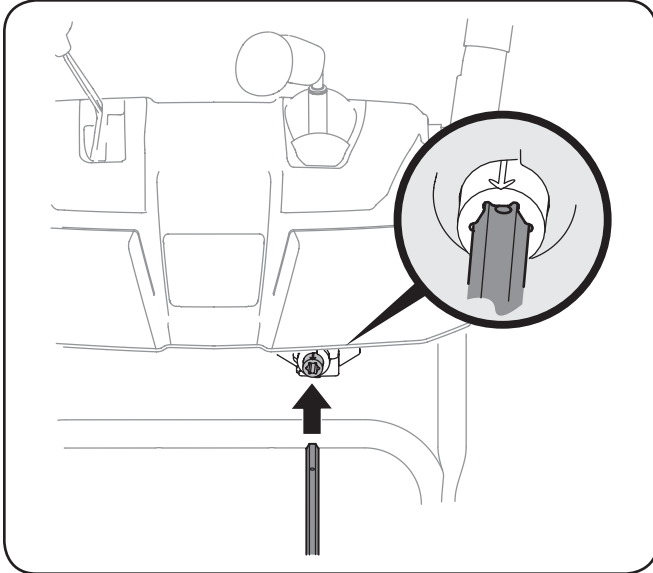

Figure 3-8

7. Push the hex rod toward the control panel until the hole in the hex rod lines up with the hole in the chute control input closest to the chute control head and insert the cotter pin. See Fig. 3-9.

**NOTE:** The second hole is used to achieve further engagement of the hex rod into the pinion gear if required. Refer to page 18 for Chute Control Rod adjustments.

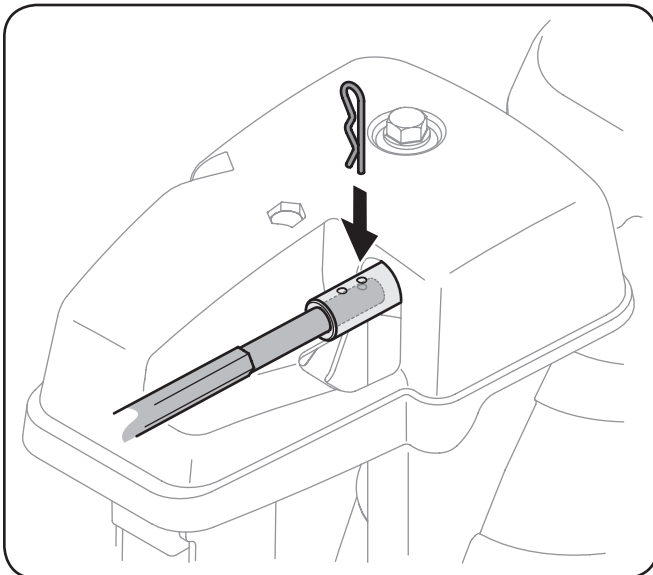

Figure 3-9

8. Finish securing chute control head to chute support bracket with wing nut, clevis pin, and bow-tie cotter pin removed in step 1. See Fig. 3-3.
9. Check that all cables are properly routed through the cable guide on top of the engine. See Fig. 3-10.

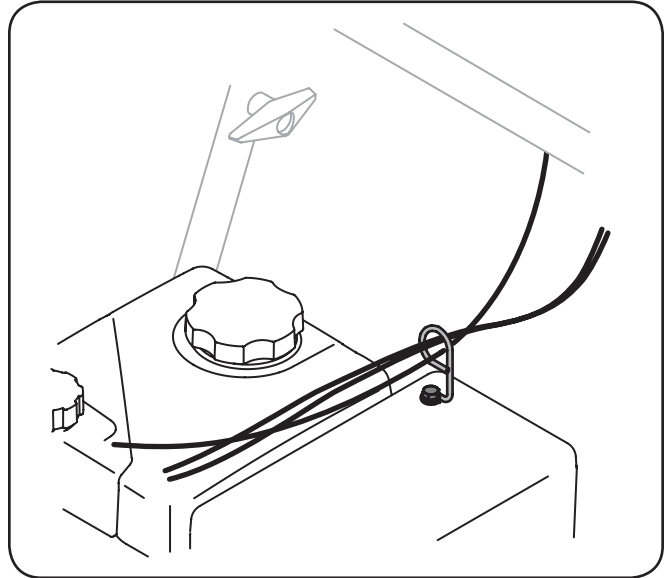

Figure 3-10

## Set-Up

### Shear Pins

A pair of replacement auger shear pins and bow tie cotter pins are included with your snow thrower in the manual bag. Store them in your snow thrower's dash panel until needed. See Fig. 3-11.

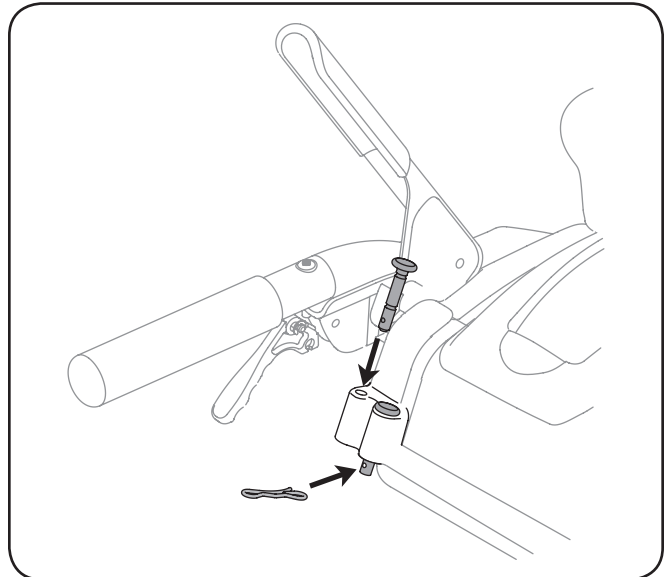

Figure 3-11

## Chute Clean-Out Tool

The chute clean-out tool is fastened to the top of the auger housing with a mounting clip and a cable tie at the factory. Cut the cable tie before operating the snow thrower. See Fig. 3-12.

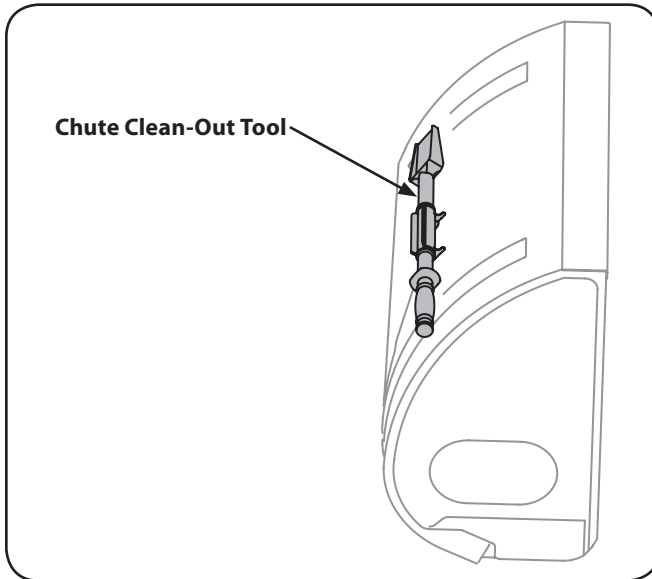

Figure 3-12

## Adjustments

### Skid Shoes

The snow thrower skid shoes are adjusted upward at the factory for shipping purposes. Adjust them downward, if desired, prior to operating the snow thrower.



**CAUTION:** It is not recommended that you operate this snow thrower on gravel as it can easily pick up and throw loose gravel, causing personal injury or damage to the snow thrower and surrounding property.

For close snow removal on a smooth surface, raise the skid shoes higher on the auger housing.

Use a middle or lower position when the area to be cleared is uneven, such as a gravel driveway.

**NOTE:** If you choose to operate the snow thrower on a gravel surface, keep the skid shoes in position for maximum clearance between the ground and the shave plate.

To adjust the skid shoes:

1. Loosen the four hex nuts (two on each side) and carriage bolts. Move the skid shoes to the desired position. See Fig. 3-13.

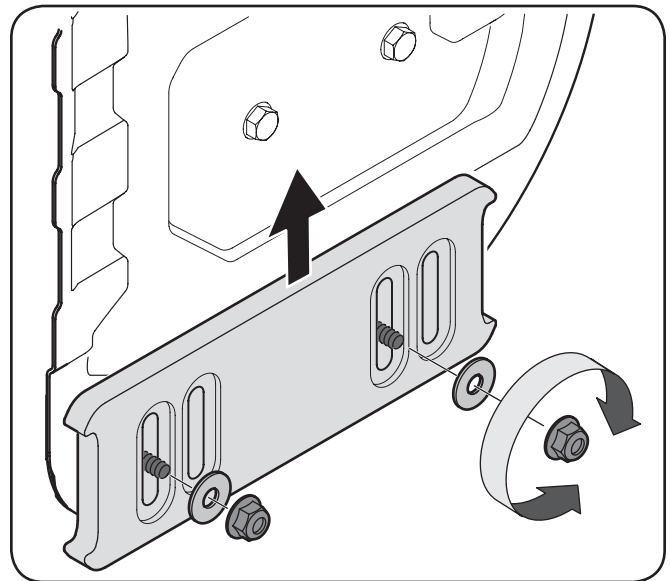

Figure 3-13

2. Make certain the entire bottom surface of the skid shoe is against the ground to avoid uneven wear on the skid shoes.
3. Retighten the nuts and bolts securely.

## Auger Control



**WARNING!** Prior to operating your snow thrower, carefully read and follow all the instructions below. Perform all adjustments to verify your snow thrower is operating safely and properly.

Check the adjustment of the auger control as follows:

1. When the auger control is released and in the disengaged “up” position, the cable should have very little slack. It should NOT be tight.
2. In a well-ventilated area, start the snow thrower engine. Refer to your Engine Operator’s Manual.
3. While standing in the operator’s position (behind the snow thrower), engage the auger.
4. Allow the auger to remain engaged for approximately ten (10) seconds before releasing the auger control. Repeat this several times.
5. With the throttle control in the FAST (rabbit) position and the auger control in the disengaged “up” position, walk to the front of the machine.
6. Confirm that the auger has completely stopped rotating and shows NO signs of motion.

**IMPORTANT:** If the auger shows ANY signs of rotating, immediately return to the operator’s position and shut off the engine as instructed in the Engine Operator’s Manual. Wait for ALL moving parts to stop before readjusting the auger control.

7. To readjust the control cable, loosen the hex jam nut on the auger control cable “Z” fitting.
8. Thread the ferrule without turning the cable onto the “Z” fitting until there is no slack in the cable. See Fig. 3-14. Do not overtighten the cable. Hold the flats on the ferrule with pliers and tighten the jam nut against the ferrule.

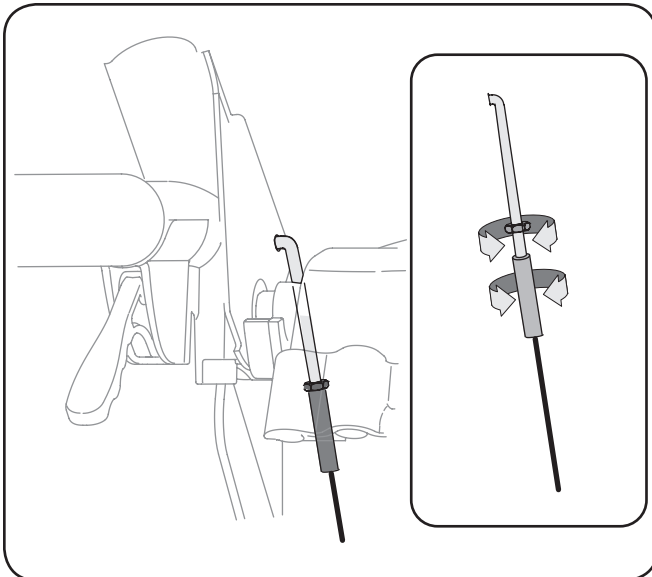

**Figure 3-14**

9. Repeat steps 2 through 6 above to verify proper adjustment has been achieved.

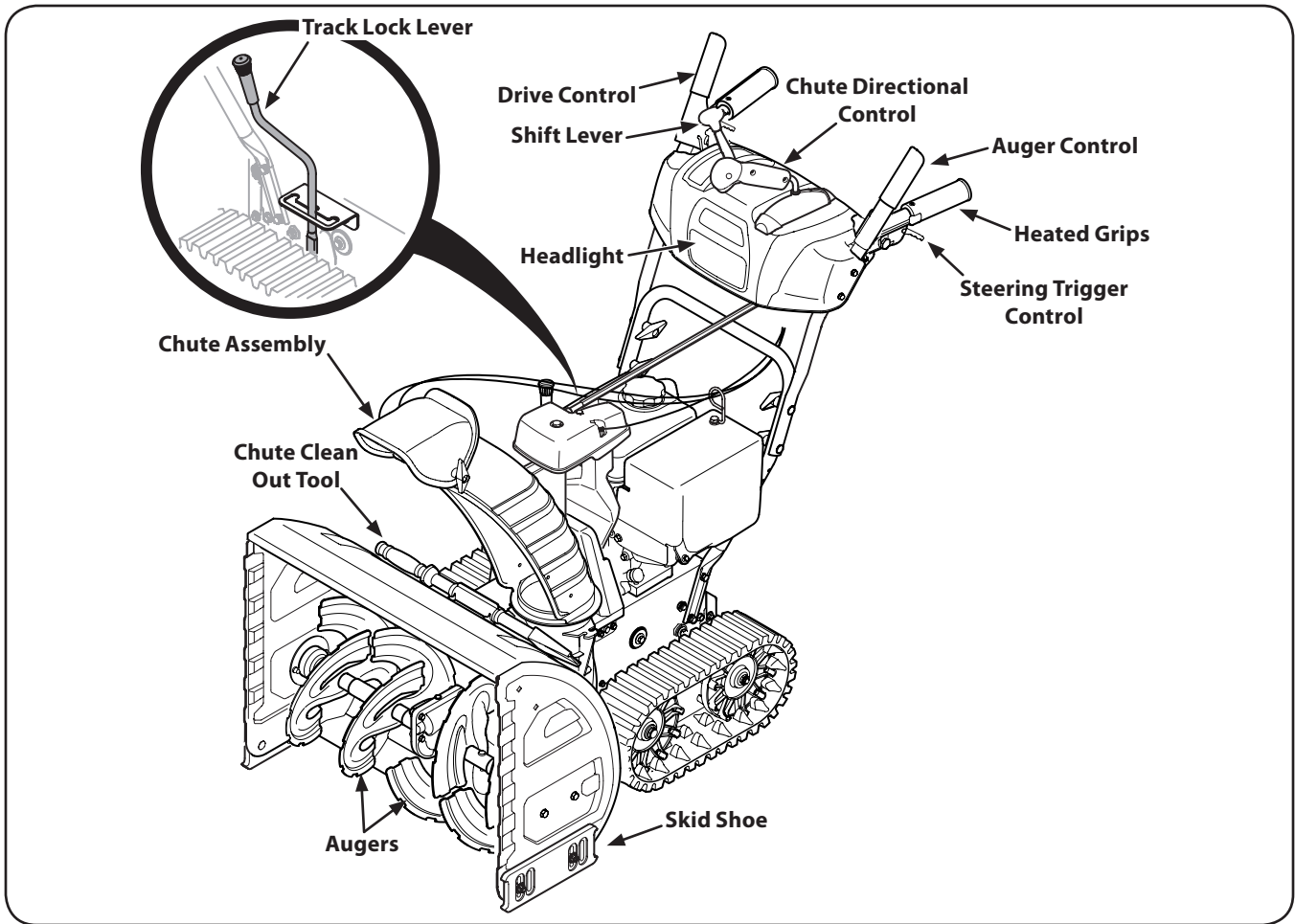

Figure 4-1



**WARNING!** Read, understand, and follow all instructions and warnings on the machine and in this manual before operating.

## Shift Lever

The shift lever is located in the right side of the handle panel and is used to determine both the ground speed and direction of travel. It can be moved into any of eight positions.

### Forward

Your snow thrower has six forward (F) speeds, with position number one (1) being the slowest.

### Reverse

Your snow thrower has two reverse (R) speeds, with position number one (1) being the slowest.

**NOTE:** Always release the drive control before changing speeds.

## Headlight

The headlight is on whenever the engine is running.

## Heated Grip



**CAUTION:** It is recommended that you wear gloves when using the heated grip. If the heated grip becomes too hot, turn it off.

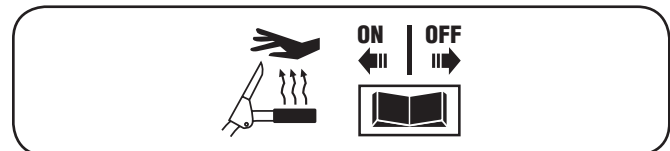

To activate the heated grips, move the switch found on the rear of the dash panel into the ON position.

## Skid Shoe

The space between the shave plate and the ground can be adjusted by positioning the skid shoes. Refer to Skid Shoe Adjustment on page 10.

## Track Drive Control / Auger Clutch Lock

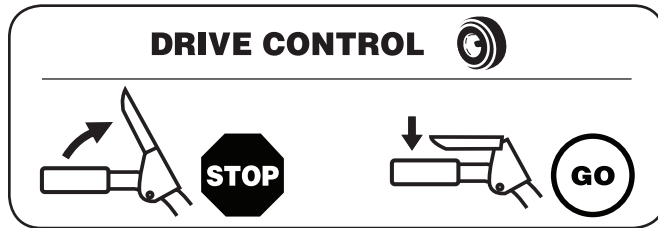

The track drive control is located on the right handle. Squeeze the control grip against the handle to engage the track drive. Release to stop.

**NOTE:** Always release the drive control before changing speeds. Failure to do so will result in increased wear on your machine's drive system.

The drive control also locks the auger control so that you can operate the chute control handle without interrupting the snow throwing process. If the auger control is engaged simultaneously with the drive control, the operator can release the auger control (on the left handle) and the augers will remain engaged. Release both controls to stop the augers and the track drive.

## Auger Control

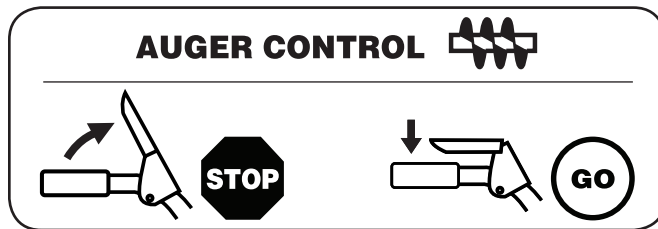

The auger control is located on the left handle. Squeeze the control grip against the handle to engage the augers and start snow throwing action. Release to stop.

## Augers

When engaged, the augers rotate and draw snow into the auger housing.

## Chute Assembly

Snow drawn into the auger housing is discharged out the chute assembly.

## Track Steering Controls

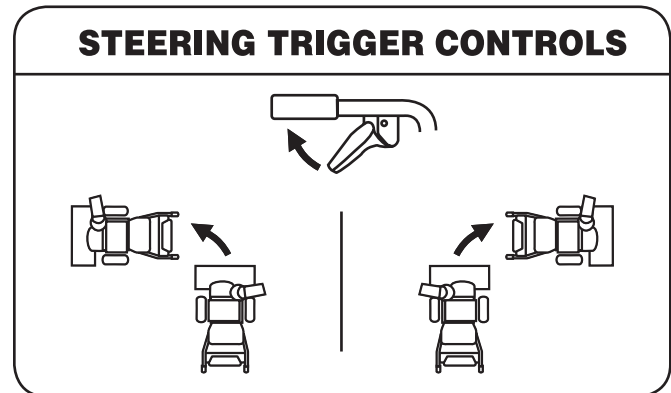

The left and right track steering controls are located on the underside of the handles and they are used to assist in steering the snow thrower. Squeeze the right track control when turning right, squeeze the left control when turning left. Operate your snow thrower in open areas until you become familiar with these controls.

**NOTE:** It is easier to maneuver a non-running snow thrower with both track steering controls held in simultaneously.

## Chute Directional Control

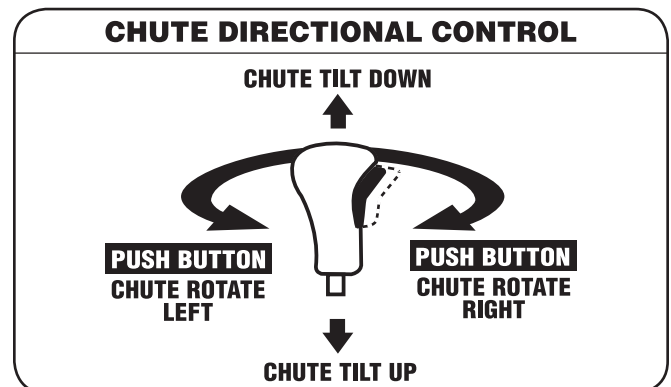

The chute directional control is located on the left side of the dash panel.

- To change the direction in which snow is thrown, squeeze the button on the joystick and pivot the joy-stick to the right or to the left.
- To change the angle/distance which snow is thrown, pivot the joystick forward or backward.

## Track Lock Lever

The track lock lever is located on the right side of the snow thrower and is used to select the position of the auger housing and the method of track operation. Move the lever to the right, then forward or backward to one of the three positions.

### Transport

Raises the front end of the snow thrower for easy transport. Using proper caution, this position may also be used on many gravel driveways to clear snow while leaving gravel undisturbed.

### Normal Snow

Allows the tracks to be suspended independently for continuous ground contact.

### Packed Snow

Locks the front end of the snow thrower down to the ground for hard-packed or icy snow conditions.

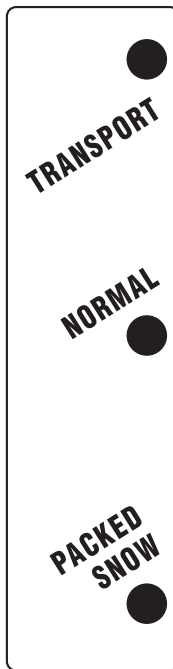

## Chute Clean-Out Tool



**WARNING!** Never use your hands to clear a clogged chute assembly. Shut off engine and remain behind handles until all moving parts have stopped before unclogging.

The chute clean-out tool is conveniently fastened to the rear of the auger housing with a mounting clip. Should snow and ice become lodged in the chute assembly during operation, proceed as follows to safely clean the chute assembly and chute opening:

1. Release both the Auger Control and the Drive Control.
2. Stop the engine as instructed in the Engine Operator's Manual. Remove the key.
3. Remove the clean-out tool from the clip which secures it to the rear of the auger housing.
4. Use the shovel-shaped end of the clean-out tool to dislodge and scoop any snow and ice which has formed in and near the chute assembly.
5. Refasten the clean-out tool to the mounting clip on the rear of the auger housing, reinsert the key and start the snow thrower's engine as instructed in the Engine Operator's Manual.

While standing in the operator's position (behind the snow thrower), engage the auger control for a few seconds to clear any remaining snow and ice from the chute assembly.

## Starting and Stopping the Engine

Refer to the Engine Operator's Manual packed with your snow thrower for instructions on starting and stopping the engine.

## To Engage Drive

1. With the throttle control in the Fast (rabbit) position, move the shift lever into one of the six forward (F) positions or two reverse (R) positions. Select a speed appropriate for the snow conditions and a pace you are comfortable with.
2. Squeeze the drive control against the handle and the snow thrower will move. Release it and the drive motion will stop.

## To Engage Augers

To engage the augers and start throwing snow, squeeze the auger control against the left handle. Release to stop the augers.

## To Steer

With the drive control engaged, squeeze the right steering trigger control to turn right. Squeeze the left steering trigger control to turn left.

## Engage Heated Grips

To activate the heated grips, move the switch found on the rear of the dash panel into the ON position. See Fig. 5-1.



**CAUTION:** It is recommended that you wear gloves when using the heated grip. If the heated grip becomes too hot, turn it off.

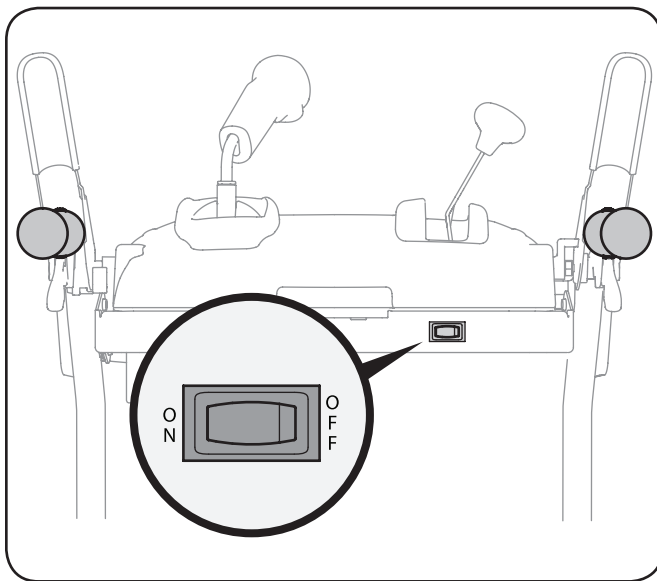

Figure 5-1

## Set Track Position

Move the track lock lever to the right, then forward or backward to one of the three positions. See Fig. 5-2.

**NOTE:** When positioning the track lock lever into one of the three operating locations, apply a downward force on the right handle with your left hand while you shift the track lock lever into the desired position with your right hand.

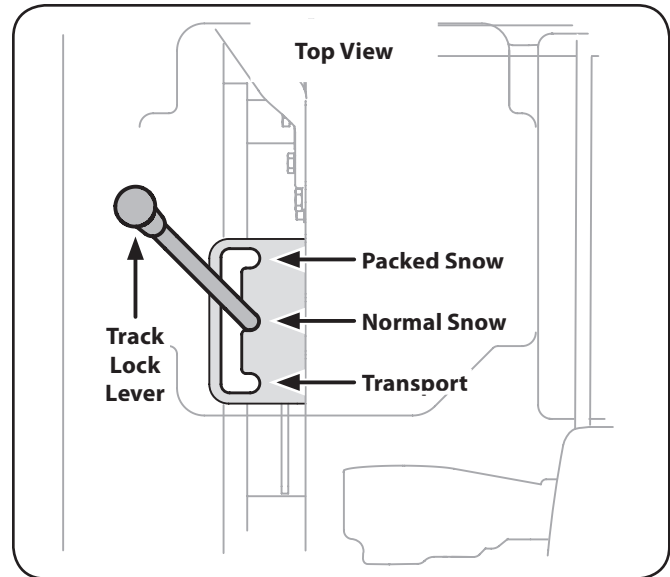

Figure 5-2

## Maintenance

### Engine

Refer to the Engine Operator's Manual.

### Shave Plate and Skid Shoes

The shave plate and skid shoes on the bottom of the snow thrower are subject to wear. They should be checked periodically and replaced when necessary.

**NOTE:** Deluxe skid shoes have two wear edges. When one side wears out, they can be rotated 180° to use the other edge.

To remove the skid shoes:

1. Remove the four carriage bolts and hex flange nuts which secure them to the snow thrower.
2. Reassemble the new skid shoes with the four carriage bolts (two on each side) and hex flange nuts. Refer to Fig. 6-1.

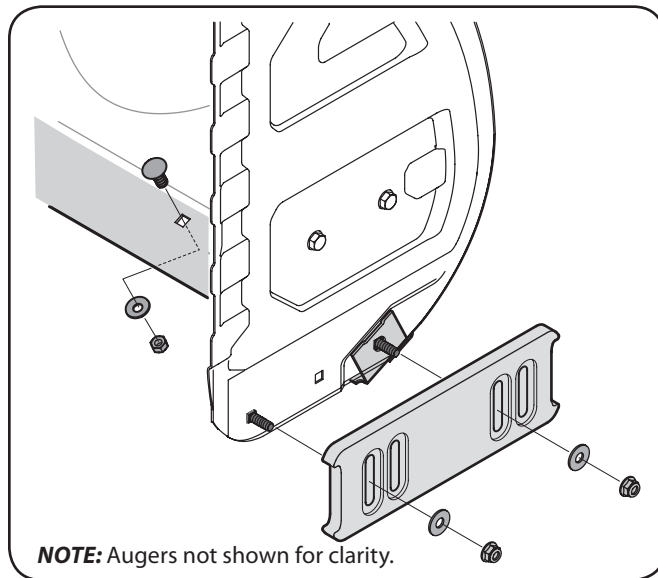

**Figure 6-1**

To remove the shave plate:

1. Remove the carriage bolts and hex nuts which attach it to the auger housing.
2. Reassemble new shave plate, making sure heads of carriage bolts are to the inside of housing. Tighten securely. Refer to Fig. 6-1.

## Lubrication

### Gear Shaft

The gear (hex) shaft should be lubricated at least once a season or after every twenty-five (25) hours of operation.

1. Run fuel tank dry, then carefully pivot the snow thrower up and forward so that it rests on the auger housing.

2. Remove the frame cover from the underside of the snow thrower by removing the self-tapping screws which secure it. Refer to Fig 6-2.

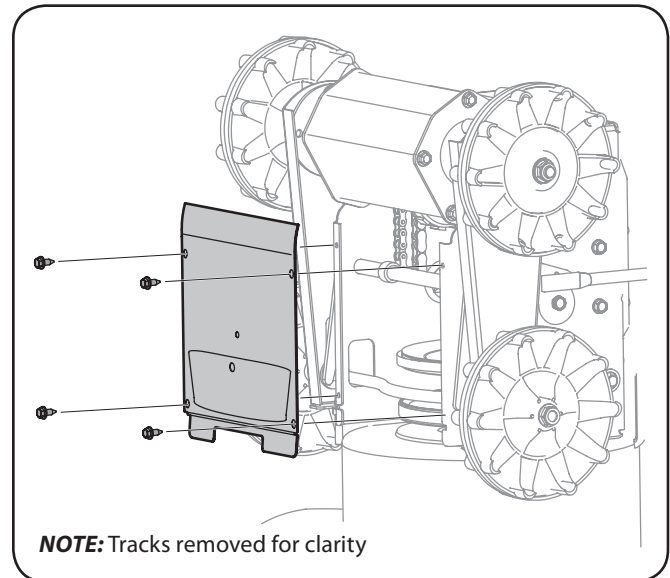

**Figure 6-2**

3. Apply a light coating of engine oil (or 3-in-1 oil) to the hex shaft. See Fig. 6-3.

**NOTE:** When lubricating the hex shaft, be careful not to get any oil on the aluminum drive plate or the rubber friction wheel. Doing so will hinder the snow thrower's drive system. Wipe off any excess or spilled oil.

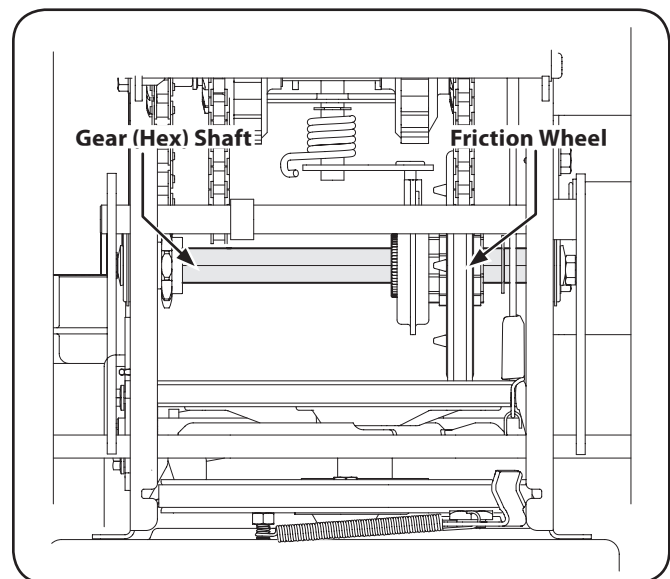

**Figure 6-3**

## Auger Shaft

At least once a season, remove the shear pins from the auger shaft. Spray lubricant inside the shaft and around the spacers and the flange bearings found at either end of the shaft. See Fig. 6-4.

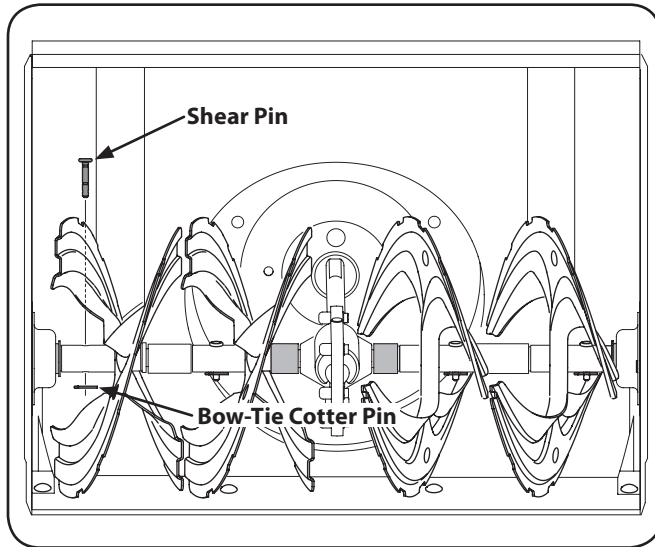

Figure 6-4

## Adjustments

### Shift Cable

If the full range of speeds (forward and reverse) cannot be achieved adjust the shift cable as follows:

1. Place the shift lever in the fastest forward speed position.
2. Loosen the hex nut on the shift cable index bracket. See Fig. 6-5.

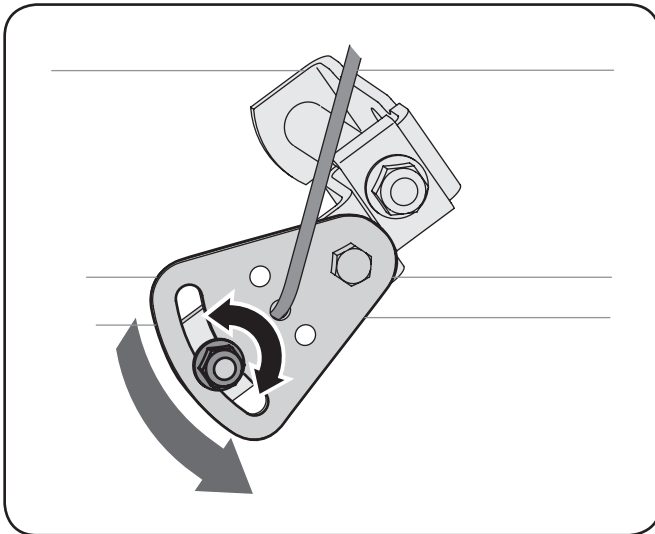

Figure 6-5

3. Pivot the bracket downward to take up slack in the cable.
4. Retighten the hex nut.

## Auger Control

Refer to the Assembly and Set-up section for instructions on adjusting the auger control cable.

## Skid Shoes

Refer to the Assembly and Set-up section for instructions on adjusting the skid shoes.

## Track Tension

Over time the track can stretch. Adjust the track tension as follows (See Fig. 6-6):

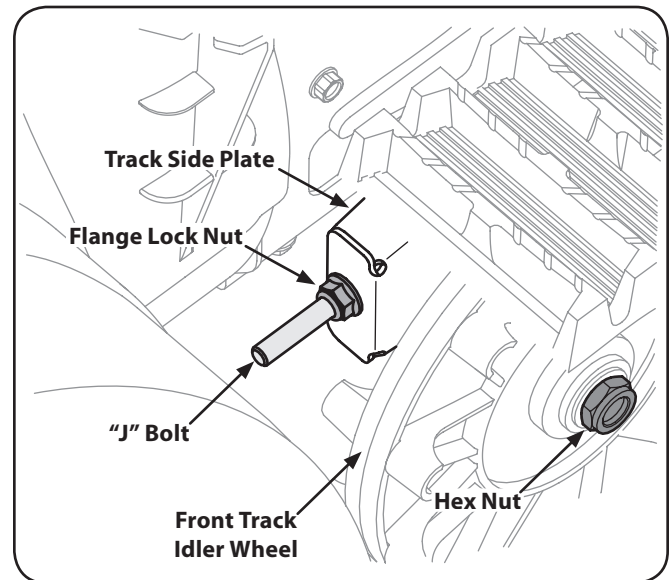

Figure 6-6

1. Loosen the hex nuts on the front track idler wheels on each side of the snow thrower.
2. Tighten the flange lock nut on the front of the track side plate. This pulls the "J" bolts attached to the axle and tightens the tracks.
3. Tighten the hex nuts on the front track idler wheels.

## Drive Control

When the drive control is released and in the disengaged “up” position, the cable should have very little slack. It should NOT be tight.

**NOTE:** If excessive slack is present in the drive cable or if the snow thrower’s drive is disengaging intermittently during operation, the cable may be in need of adjustment.

Check the adjustment of the drive control as follows:

1. With the drive control released, push the snow thrower gently forward. The unit should roll freely.
2. Engage the drive control and gently attempt to push the snow thrower forward. The tracks should not turn. The unit should not roll freely.
3. With the drive control released, move the shift lever back and forth between the R2 position and the F6 position several times. There should be no resistance in the shift lever.

If any of the above tests failed, the drive cable is in need of adjustment. Proceed as follows:

1. To readjust the drive, loosen the hex jam nut on the auger control cable “Z” fitting.
2. Thread the ferrule without turning the cable onto the “Z” fitting until there is no slack in the cable. See Fig. 6-7. Do not overtighten the cable. Hold the flats on the ferrule with pliers and tighten the jam nut against the ferrule.

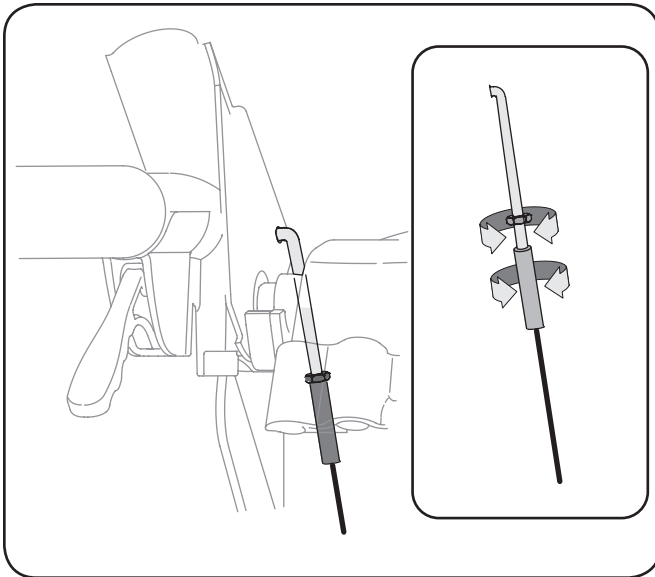

Figure 6-7

3. Rotate the coupling end of the cable counterclockwise to provide more slack or clockwise to decrease the slack in the cable.
4. Retighten the hex jam nut. See Fig. 6-7.
5. Check the adjustment of the drive control as described above to verify proper adjustment has been achieved.

## Chute Directional Control

To adjust the chute control rod, proceed as follows:

1. Remove the cotter pin from the hole closest to the chute assembly on the chute rotation assembly.
2. Pull out the chute control rod until the hole in it lines up with the second hole in the chute rotation assembly. See Fig. 6-8.

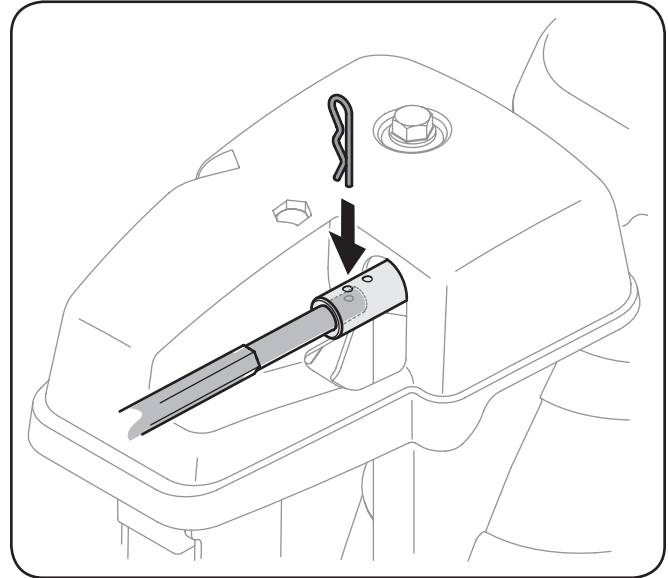

Figure 6-8

3. Reinsert the cotter pin through this hole and the chute control rod. See Fig. 6-8.

## Off-Season Storage

If the snow thrower will not be used for 30 days or longer, follow the storage instructions below.

1. Run the engine until the fuel tank is empty and it stops due to lack of fuel. Do not attempt to pour fuel from the engine.
2. Lubricate the machine as instructed earlier in this section.
3. Store in a clean, dry area.
4. If storing the snow thrower in an unventilated area, rustproof the machine using a light oil or silicone to coat the snow thrower.
5. Clean the exterior of the engine and the snow thrower.

**NOTE:** Refer to the Engine Operator’s Manual for information on storing your engine.

## Belt Replacement

### Auger Belt

**NOTE:** It is not necessary to remove both belts in order to change either one. If changing just one belt, be certain to check the condition of the other belt.

1. Allow the engine to run until it is out of fuel. Do not attempt to pour fuel from the engine. Remove the key to avoid unintended starting.
2. Remove the plastic belt cover at the front of the engine by removing the two self-tapping screws. See Fig. 7-1.

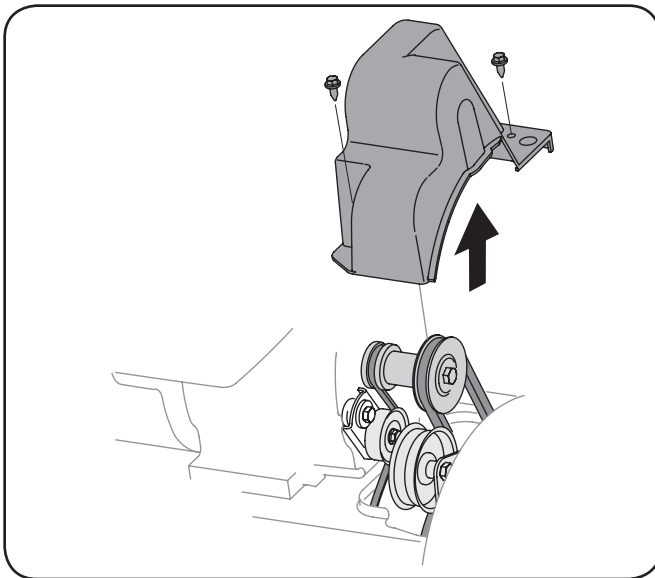

**Figure 7-1**

3. Tip the snow thrower up and forward so that it rests on its auger housing.

4. Remove the frame cover from the underside of the snow thrower by removing the self-tapping screws which secure it. See Fig. 7-2.

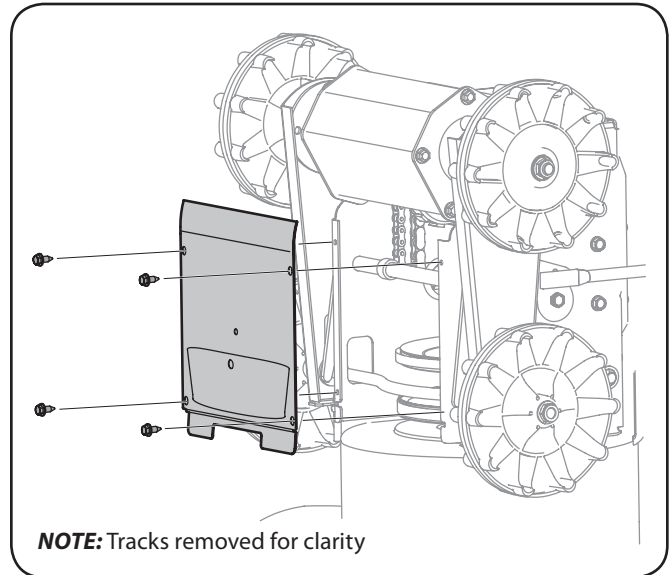

**Figure 7-2**

5. Roll the auger belt off the engine pulley. See Fig. 7-3.

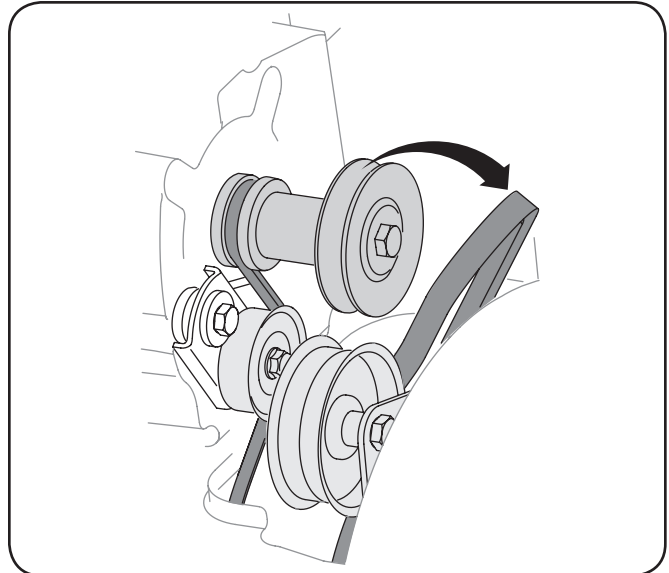

**Figure 7-3**

- Unhook the idler spring from the hex bolt on the auger housing. See Fig. 7-4.

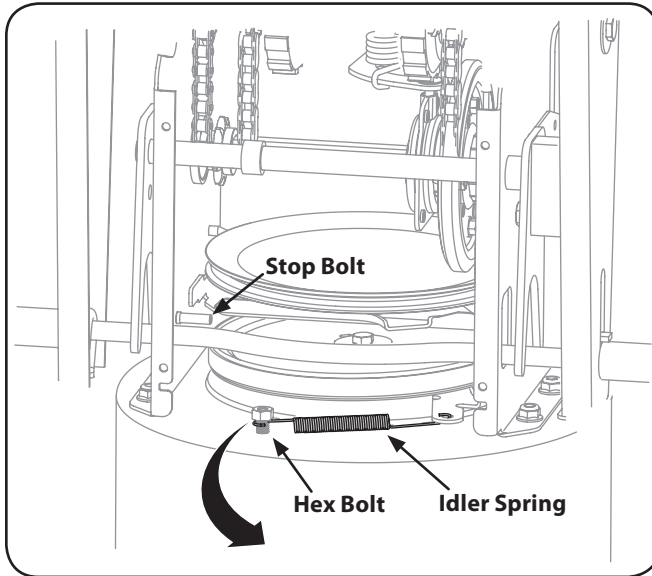

**Figure 7-4**

- Lift the auger belt from the auger pulley, and slip belt between the support bracket and the auger pulley. See Fig. 7-5.

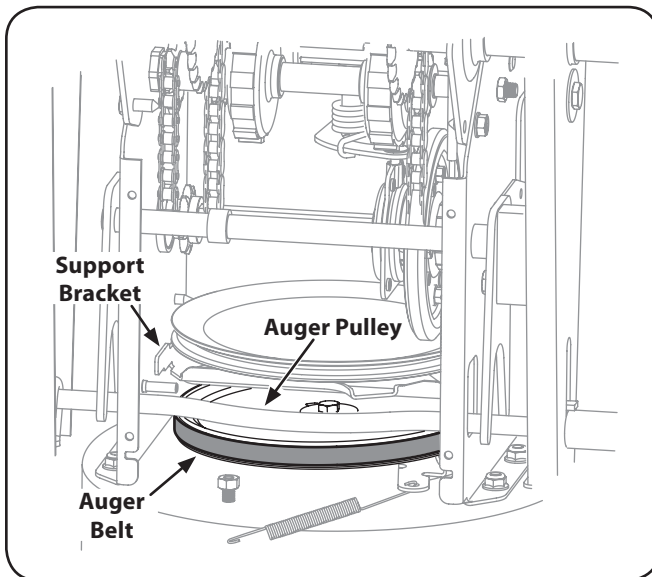

**Figure 7-5**

- Replace auger drive belt by following instructions in reverse order.
- Repeat the Auger Control Test on page 11.

## Drive Belt

To remove and replace your snow thrower's drive belt, proceed as follows:

- To prevent spillage, remove all fuel from tank by running engine until it stops. Do not attempt to pour fuel from the engine.
- Remove the plastic belt cover on the front of the engine by removing the two self-tapping screws. Ref. Fig. 7-1.
- Carefully pivot the snow thrower up and forward so that it rests on the auger housing.
- Remove the frame cover from the underside of the snow thrower by removing self-tapping screws which secure it. Ref. Fig. 7-2.
- To remove the belt from the pulleys proceed as follows:
  - Roll the auger belt off the engine pulley.
  - Pivot the idler pulley toward the right. See Fig. 7-6.
  - Lift the drive belt off engine pulley.

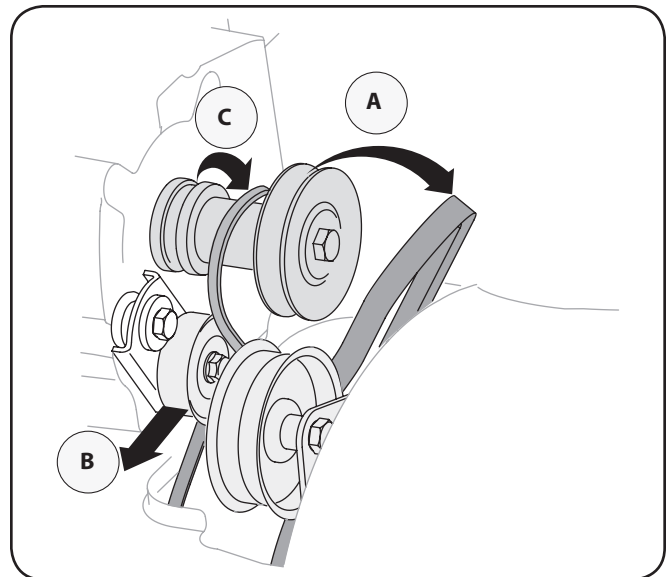

**Figure 7-6**

- Back out the stop bolt until the support bracket rests on the auger pulley. See Fig. 7-4.

- Slip the drive belt off the pulley and between friction wheel and drive pulley. See Fig. 7-7.

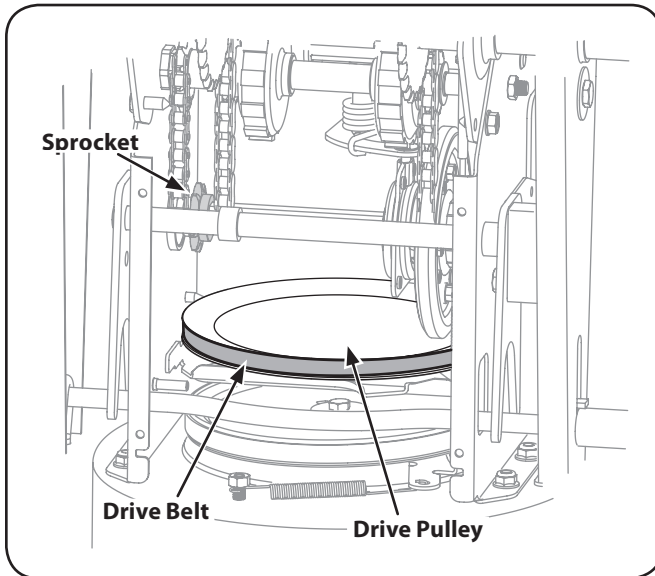

**Figure 7-7**

- Remove and replace belt in the reverse order.  
**NOTE:** Engaging the drive control will ease re-assembly of the belt.
- Reinstall the stop bolt.

## Friction Wheel Removal

The rubber on the friction wheel is subject to wear and should be checked after 25 hours of operation, and periodically thereafter. Replace the friction wheel rubber if any signs of wear or cracking are found.

- Allow the engine to run until it is out of fuel. Do not attempt to pour fuel from the engine.
- Tip the snow thrower up and forward, so that it rests on the housing.
- Remove the self-tapping screws from the frame cover underneath the snow thrower.
- Using a  $\frac{3}{4}$ " wrench to hold the gear shaft, remove the hex bolt and bell washer on the left end of the gear shaft. See Fig. 7-8 and 7-9.

**NOTE:** Tracks removed for clarity

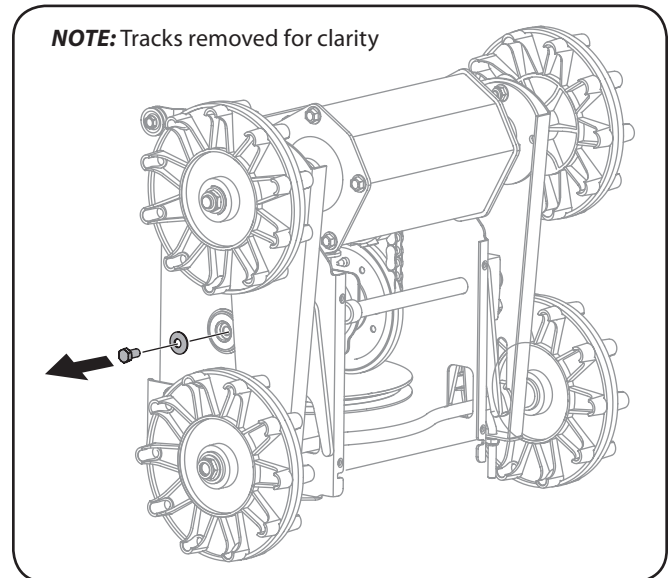

**Figure 7-8**

- Move the gear shaft to the right and slide the friction wheel assembly from the shaft. See Fig. 7-9.

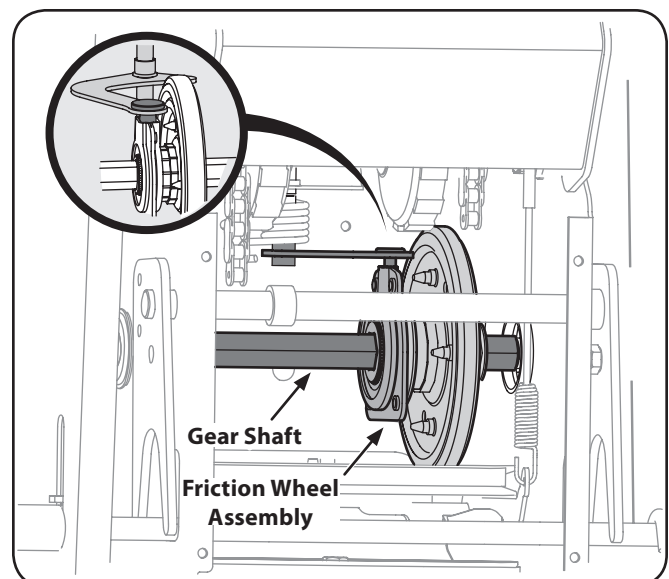

**Figure 7-9**

6. If replacing the entire assembly, put the new friction wheel assembly in place and follow the steps in reverse to re-assemble. Repeat the drive control test on page 18. If you only want to replace the friction wheel rubber, continue with step 7.

**NOTE:** Make sure to install the gear shaft through the sprocket shown in Fig. 7-7. If the sprocket fell from the snow thrower while removing the hex shaft, place the sprocket on the hex shaft. Position the hex hub of the sprocket toward the friction wheel when sliding the sprocket onto the shaft. See Fig. 7-7.

7. Remove the four screws from the friction wheel assembly. See Fig. 7-10.

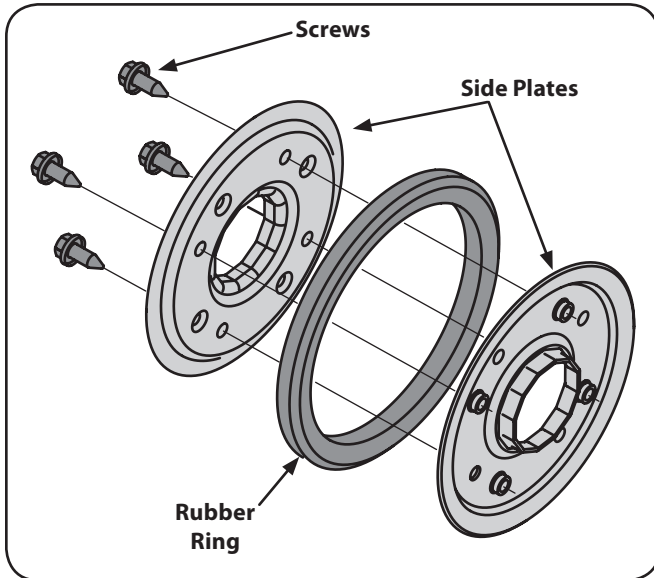

Figure 7-10

8. Remove the friction wheel rubber from between the friction wheel plates.
9. Reassemble new friction wheel rubber to the friction wheel plates and hub, tightening the four screws in rotation and with equal force (between 6 ft.-lbs. and 9 ft.-lbs.).

**NOTE:** When reassembling the friction wheel assembly, make sure that the rubber ring is centered and seated properly between the side plates. Tighten each screw only one rotation before turning the wheel clockwise and proceeding with the next screw. Repeat this process several times to ensure the plates are secured with equal force (between 6 ft.-lbs and 9 ft.-lbs).



**NOTE:** Make sure the shift lever pin is in place in the bearing housing. See Fig. 7-9 inset.

10. Position the friction wheel assembly up onto the pin of the shift rod assembly, and slide the shaft through the assembly. See Fig. 7-9. Reassemble in reverse order.

**NOTE:** Make sure to install the gear shaft through the sprocket shown in Fig. 7-7. If the sprocket fell from the snow thrower while removing the hex shaft, place the sprocket on the hex shaft. Position the hex hub of the sprocket toward the friction wheel when sliding the sprocket onto the shaft. See Fig. 7-7.

11. Repeat the drive control test on page 18.

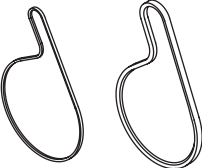
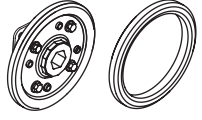
Problem	Cause	Remedy
Engine fails to start	<ol style="list-style-type: none"> <li>1. Fuel tank empty, or stale fuel.</li> <li>2. Blocked fuel line.</li> <li>3. Choke not in the RUN position.</li> <li>4. Faulty spark plug.</li> <li>5. Key not in ignition switch on engine.</li> <li>6. Spark plug wire disconnected.</li> <li>7. Primer button not being used properly.</li> </ol>	<ol style="list-style-type: none"> <li>1. Fill tank with clean, fresh gasoline. Fuel becomes stale after thirty days.</li> <li>2. Clean the fuel line.</li> <li>3. Move choke control to RUN position</li> <li>4. Clean, adjust gap or replace.</li> <li>5. Insert the key fully into the switch.</li> <li>6. Connect spark plug wire.</li> <li>7. Refer to the Engine Operator's Manual.</li> </ol>
Engine running erratically/ inconsistent RPM (hunting or surging)	<ol style="list-style-type: none"> <li>1. Engine running on CHOKE.</li> <li>2. Fuel line blocked or stale fuel.</li> <li>3. Water or dirt in fuel system.</li> <li>4. Carburetor out of adjustment.</li> <li>5. Over-governed engine.</li> </ol>	<ol style="list-style-type: none"> <li>1. Move choke control to RUN position.</li> <li>2. Clean fuel line and fill tank with fresh clean, gasoline.</li> <li>3. Run engine until it stops. Refill with fresh fuel.</li> <li>4. Contact an authorized service center.</li> <li>5. Contact an authorized service center.</li> </ol>
Loss of power	<ol style="list-style-type: none"> <li>1. Spark plug wire loose.</li> <li>2. Gas cap vent hole plugged.</li> </ol>	<ol style="list-style-type: none"> <li>1. Connect and tighten spark plug wire.</li> <li>2. Remove ice and snow from gas cap. Be certain vent hole is clear.</li> </ol>
Excessive vibration	<ol style="list-style-type: none"> <li>1. Loose parts or damaged auger.</li> </ol>	<ol style="list-style-type: none"> <li>1. Stop the engine immediately and disconnect the spark plug wire. Tighten all bolts and nuts. If vibration continues, have the snow thrower serviced by an authorized service dealer.</li> </ol>
Snow Thrower fails to propel itself	<ol style="list-style-type: none"> <li>1. Drive control cable in need of adjustment.</li> <li>2. Drive belt loose or damaged.</li> <li>3. Friction wheel worn.</li> </ol>	<ol style="list-style-type: none"> <li>1. Adjust drive control cable. Refer to Maintenance &amp; Adjustments Section.</li> <li>2. Replace drive belt. Refer to the Service Section.</li> <li>3. Replace the friction wheel.</li> </ol>
Snow Thrower fails to discharge snow	<ol style="list-style-type: none"> <li>1. Chute assembly clogged.</li> <li>2. Shear pin(s) sheared.</li> <li>3. Foreign object lodged in auger.</li> <li>4. Auger control cable in need of adjustment.</li> <li>5. Auger belt loose or damaged.</li> </ol>	<ol style="list-style-type: none"> <li>1. Stop engine and disconnect spark plug wire. Clean chute and inside of auger housing with clean-out tool or a stick.</li> <li>2. Replace shear pin(s).</li> <li>3. Stop engine immediately and disconnect spark plug wire. Remove object from auger.</li> <li>4. Adjust auger control cable. Refer to the Maintenance &amp; Adjustments Section.</li> <li>5. Refer to Service Section.</li> </ol>
Chute fails to easily rotate 180 degrees	<ol style="list-style-type: none"> <li>1. Chute assembled incorrectly.</li> </ol>	<ol style="list-style-type: none"> <li>1. Unassemble chute control and reassemble as directed in the Assembly section.</li> </ol>

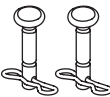
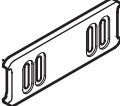
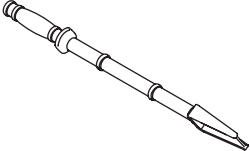
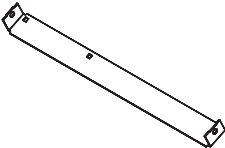
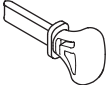
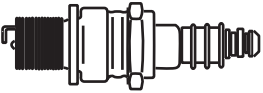
Component	Part Number and Description
	929-0071A      Extension Cord, 110V
	954-04050      Auger Drive Belt 954-04260      Wheel Drive Belt
	684-04159      Friction Wheel Assembly 935-04054      Friction Wheel Rubber
	725-1629      Lamp, 12 Volt
	738-04124A      Shear Pin, 1.50 714-04040      Bow-tie Cotter Pin
	731-06931      Skid Shoe, Polymer
	931-2643      Chute Clean-out Tool
	790-00148      Stainless Steel Shave Plate, 26" 790-00121      Shave Plate, 26"
	731-05632      Key
	951-10292      Spark Plug

Contact your Cub Cadet dealer to order replacement parts or a complete Parts Manual (have your full model number and serial number ready). Parts Manual downloads are also available free of charge at [www.cubcadet.com](http://www.cubcadet.com).

The following attachments and accessories are available for your Cub Cadet snow thrower. Contact your Cub Cadet dealer for information regarding compatibility, price and availability (have your full model number and serial number ready).

<b>Model Number</b>	<b>Description</b>
OEM-390-679	Drift Cutter Kit
OEM-390-995	Snow Thrower Protective Cover
490-241-0010	Polymer Skid Shoe Kit
490-241-0013	Snow Thrower Maintenance Kit





---

## CUB CADET LLC MANUFACTURER'S LIMITED WARRANTY FOR SNOW THROWERS

The limited warranty set forth below is given by Cub Cadet LLC with respect to new merchandise purchased and used in the United States, its possessions and territories, and by MTD Products Limited with respect to new merchandise purchased and used in Canada and/or its territories and possessions.

**For non-commercial use:** Cub Cadet warrants this product (excluding *Normal Wear Parts*, as described below) against defects in material and workmanship for a period of three (3) years from the date of original retail purchase or lease.

**For commercial uses and applications:** Cub Cadet warrants this product (excluding *Normal Wear Parts*, as described below) against defects in material and workmanship for a period of one (1) year from the date of original retail purchase or lease.

"Cub Cadet" will, at its option, repair or replace, free of charge, any part found to be defective in materials or workmanship. This limited warranty shall only apply if this product has been operated and maintained in accordance with the Operator's Manual furnished with the product, and has not been subject to misuse, abuse, neglect, accident, improper maintenance, alteration, vandalism, theft, fire, water, or damage because of other peril or natural disaster. Damage resulting from the installation or use of any part, accessory or attachment not approved by Cub Cadet for use with the product(s) covered by this manual will void your warranty as to any resulting damage.

*Normal Wear Parts* are warranted to be free from defects in material and workmanship for a period of thirty (30) days from the date of purchase. Normal wear parts include, but are not limited to items such as: belts, skid shoes, shave plates and tires.

**HOW TO OBTAIN SERVICE:** Warranty service is available, WITH PROOF OF PURCHASE, through your local authorized service dealer. To locate the dealer in your area:

### **In the U.S.A.**

To locate the dealer in your area, check your Yellow Pages, or contact Cub Cadet LLC at P.O. Box 361131, Cleveland, Ohio 44136-0019, or call 1-877-282-8684, or log on to our Web site at [www.cubcadet.com](http://www.cubcadet.com).

### **In Canada**

Contact MTD Products Limited, Kitchener, ON N2G 4J1, or call 1-800-668-1238 or log on to our Web site at [www.mtdcanada.com](http://www.mtdcanada.com).

This limited warranty does not provide coverage in the following cases:

- a. Routine maintenance items such as lubricants, filters, blade sharpening, tune-ups, brake adjustments, clutch adjustments, deck adjustments, and normal deterioration of the exterior finish due to use or exposure.

- b. Cub Cadet does not extend any warranty for products sold or exported outside of the United States and/or Canada, and their respective possessions and territories, except those sold through Cub Cadet's authorized channels of export distribution.
- c. Replacement parts that are not genuine Cub Cadet parts.
- d. Service completed by someone other than an authorized service dealer.
- e. Transportation charges and service calls.

**No implied warranty, including any implied warranty of merchantability of fitness for a particular purpose, applies after the applicable period of express written warranty above as to the parts as identified. No other express warranty, whether written or oral, except as mentioned above, given by any person or entity, including a dealer or retailer, with respect to any product, shall bind Cub Cadet. During the period of the warranty, the exclusive remedy is repair or replacement of the product as set forth above.**

**The provisions as set forth in this warranty provide the sole and exclusive remedy arising from the sale. Cub Cadet shall not be liable for incidental or consequential loss or damage including, without limitation, expenses incurred for substitute or replacement lawn care services or for rental expenses to temporarily replace a warranted product.**

Some states do not allow the exclusion or limitation of incidental or consequential damages, or limitations on how long an implied warranty lasts, so the above exclusions or limitations may not apply to you.

In no event shall recovery of any kind be greater than the amount of the purchase price of the product sold. **Alteration of safety features of the product shall void this warranty.** You assume the risk and liability for loss, damage, or injury to you and your property and/or to others and their property arising out of the misuse or inability to use the product.

This limited warranty shall not extend to anyone other than the original purchaser or to the person for whom it was purchased as a gift.

**HOW STATE LAW RELATES TO THIS WARRANTY:** This limited warranty gives you specific legal rights, and you may also have other rights that vary in different jurisdictions.

**IMPORTANT:** Owner must present Original Proof of Purchase to obtain warranty coverage.

**Cub Cadet LLC, P.O. BOX 361131 CLEVELAND, OHIO 44136-0019; Phone: 1-877-282-8684  
MTD Canada Limited - KITCHENER, ON N2G 4J1; Phone 1-800-668-1238**