

Cub Cadet.

OPERATOR'S MANUAL

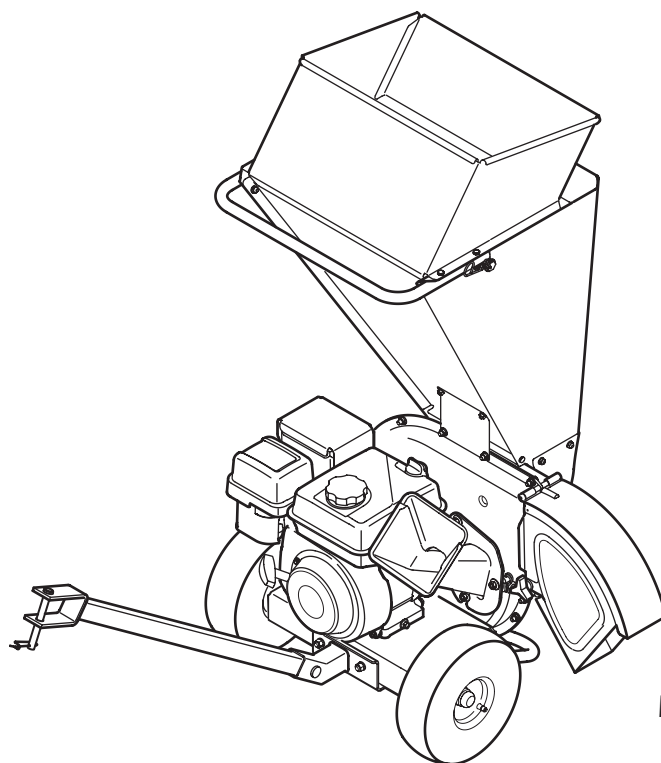

Model Series CS 2210

Chipper Shredder — Model Series CS 2210 & CS 3210

⚠ WARNING

**READ AND FOLLOW ALL SAFETY RULES AND INSTRUCTIONS IN THIS MANUAL
BEFORE ATTEMPTING TO OPERATE THIS MACHINE.
FAILURE TO COMPLY WITH THESE INSTRUCTIONS MAY RESULT IN PERSONAL INJURY.**

CUB CADET LLC, P.O. BOX 361131 CLEVELAND, OHIO 44136-0019

Thank You

Thank you for purchasing a Chipper Shredder manufactured by Cub Cadet. It was carefully engineered to provide excellent performance when properly operated and maintained.

Please read this entire manual prior to operating the equipment. It instructs you how to safely and easily set up, operate and maintain your machine. Please be sure that you, and any other persons who will operate the machine, carefully follow the recommended safety practices at all times. Failure to do so could result in personal injury or property damage.

All information in this manual is relative to the most recent product information available at the time of printing. Review this manual frequently to familiarize yourself with the machine, its features and operation. Please be aware that this Operator's Manual may cover a range of product specifications for various models. Characteristics and features discussed and/or illustrated in this manual may not be applicable to all models. Cub Cadet reserves the right to change product specifications, designs and equipment without notice and without incurring obligation.

If you have any problems or questions concerning the machine, phone your local Cub Cadet dealer or contact us directly. Cub Cadet's Customer Support telephone numbers, website address and mailing address can be found on this page. We want to ensure your complete satisfaction at all times.

Throughout this manual, all references to *right* and *left* side of the machine are observed from the operating position

The engine manufacturer is responsible for all engine-related issues with regards to performance, power-rating, specifications, warranty and service. Please refer to the engine manufacturer's Owner's/Operator's Manual, packed separately with your machine, for more information.

Table of Contents

Safe Operation Practices	3	Service	14
Assembly & Set-Up	7	Troubleshooting	16
Controls & Features	9	Replacement Parts	17
Operation	10	Back Cover	20
Maintenance & Adjustment	12		

Record Product Information

Before setting up and operating your new equipment, please locate the model plate on the equipment and record the information in the provided area to the right. This information will be necessary, should you seek technical support via our web site, Customer Support Department, or with a local authorized service dealer.

MODEL NUMBER

--	--	--	--	--	--	--	--	--	--	--

SERIAL NUMBER

--	--	--	--	--	--	--	--	--	--	--

Customer Support

If you have difficulty assembling this product or have any questions regarding the controls, operation, or maintenance of this machine, you can seek help from the experts. Choose from the options below:

- ◇ Visit us on the web at www.cubcadet.com
- ◇ Call a Customer Support Representative at (800) 965-4CUB
- ◇ Locate your nearest Cub Cadet Dealer at (877) 282-8684
- ◇ Write us at Cub Cadet • P.O. Box 361131 • Cleveland, OH • 44136-0019



WARNING: This symbol points out important safety instructions which, if not followed, could endanger the personal safety and/or property of yourself and others. Read and follow all instructions in this manual before attempting to operate this machine. Failure to comply with these instructions may result in personal injury. When you see this symbol. **HEED ITS WARNING!**

CALIFORNIA PROPOSITION 65



WARNING: Engine Exhaust, some of its constituents, and certain vehicle components contain or emit chemicals known to State of California to cause cancer and birth defects or other reproductive harm.



DANGER: This machine was built to be operated according to the safe operation practices in this manual. As with any type of power equipment, carelessness or error on the part of the operator can result in serious injury. This machine is capable of amputating fingers, hands, toes and feet and throwing debris. Failure to observe the following safety instructions could result in serious injury or death.

Training

1. Read, understand, and follow all instructions on the machine and in the manual(s) before attempting to assemble and operate. Keep this manual in a safe place for future and regular reference and for ordering replacement parts.
2. Be familiar with all controls and their proper operation. Know how to stop the machine and disengage them quickly.
3. Never allow children under 16 years of age to operate this machine. Children 16 and over should read and understand the instructions and safe operation practices in this manual and on the machine and be trained and supervised by an adult.
4. Never allow adults to operate this machine without proper instruction.
5. Keep bystanders, pets, and children at least 75 feet from the machine while it is in operation. Stop machine if anyone enters the area.
6. Never run an engine indoors or in a poorly ventilated area. Engine exhaust contains carbon monoxide, an odorless and deadly gas.
7. Do not put hands and feet near rotating parts or in the feeding chambers and discharge opening. Contact with the rotating impeller can amputate fingers, hands, and feet.

8. Never attempt to unclog either the feed intake or discharge opening, remove or empty bag, or inspect and repair the machine while the engine is running. Shut the engine off and wait until all moving parts have come to a complete stop. Disconnect the spark plug wire and ground it against the engine.

Preparation

1. Thoroughly inspect the area where the equipment is to be used. Remove all rocks, bottles, cans, or other foreign objects which could be picked up or thrown and cause personal injury or damage to the machine.
2. Always wear safety glasses or safety goggles during operation and while performing an adjustment or repair, to protect your eyes. Thrown objects which ricochet can cause serious injury to the eyes.
3. Wear sturdy, rough-soled work shoes and close-fitting slacks and shirts. Loose fitting clothes or jewelry can be caught in movable parts. Never operate this machine in bare feet or sandals. Wear leather work gloves when feeding material in the chipper chute.
4. Before starting, check all bolts and screws for proper tightness to be sure the machine is in safe working condition. Also, visually inspect machine for any damage at frequent intervals.
5. Maintain or replace safety and instructions labels, as necessary.

Safe Handling of Gasoline:

To avoid personal injury or property damage use extreme care in handling gasoline. Gasoline is extremely flammable and the vapors are explosive. Serious personal injury can occur when gasoline is spilled on yourself or your clothes which can ignite. Wash your skin and change clothes immediately.

- a. Use only an approved gasoline container.
- b. Never fill containers inside a vehicle or on a truck or trailer bed with a plastic liner. Always place containers on the ground away from your vehicle before filling.
- c. When practical, remove gas-powered equipment from the truck or trailer and refuel it on the ground. If this is not possible, then refuel such equipment on a trailer with a portable container, rather than from a gasoline dispenser nozzle.
- d. Keep the nozzle in contact with the rim of the fuel tank or container opening at all times until fueling is complete. Do not use a nozzle lock-open device.
- e. Extinguish all cigarettes, cigars, pipes and other sources of ignition.
- f. Never fuel machine indoors.
- g. Never remove gas cap or add fuel while the engine is hot or running. Allow engine to cool at least two minutes before refueling.
- h. Never over fill fuel tank. Fill tank to no more than ½ inch below bottom of filler neck to allow space for fuel expansion.
- i. Replace gasoline cap and tighten securely.
- j. If gasoline is spilled, wipe it off the engine and equipment. Move unit to another area. Wait 5 minutes before starting the engine.
- k. To reduce fire hazards, keep machine free of grass, leaves, or other debris build-up. Clean up oil or fuel spillage and remove any fuel soaked debris.
- l. Never store the machine or fuel container inside where there is an open flame, spark or pilot light as on a water heater, space heater, furnace, clothes dryer or other gas appliances.

Operation

1. Do not put hands and feet near rotating parts or in the feeding chambers and discharge opening. Contact with the rotating impeller can amputate fingers, hands, and feet.
2. Before starting the machine, make sure the chipper chute, feed intake, and cutting chamber are empty and free of all debris.
3. Thoroughly inspect all material to be shredded and remove any metal, rocks, bottles, cans, or other foreign objects which could cause personal injury or damage to the machine.

4. If it becomes necessary to push material through the shredder hopper, use a small diameter stick. Do not use your hands or feet.
5. If the impeller strikes a foreign object or if your machine should start making an unusual noise or vibration, immediately shut the engine off. Allow the impeller to come to a complete stop. Disconnect the spark plug wire, ground it against the engine and perform the following steps:
 - a. Inspect for damage.
 - b. Repair or replace any damaged parts.
 - c. Check for any loose parts and tighten to assure continued safe operation.
6. Do not allow an accumulation of processed material to build up in the discharge area. This can prevent proper discharge and result in kickback of material through the feed opening.
7. Do not attempt to shred or chip material larger than specified on the machine or in this manual. Personal injury or machine damage could result.
8. Never attempt to unclog either the feed intake or discharge opening while the engine is running. Shut the engine off, wait until all moving parts have stopped, disconnect the spark plug wire and ground it against the engine before clearing debris.
9. Never operate without the shredder hopper, chipper chute, or chute deflector properly attached to the machine. Never empty or change discharge bag while the engine is running.
10. Keep all guards, deflectors and safety devices in place and operating properly.
11. Keep your face and body back and to the side of the chipper chute while feeding material into the machine to avoid accidental kickback injuries.
12. Never operate this machine without good visibility or light.
13. Do not operate this machine on a paved, gravel or non-level surface.
14. Do not operate this machine while under the influence of alcohol or drugs.
15. Muffler and engine become hot and can cause a burn. Do not touch.
16. Never pick up or carry machine while the engine is running.
17. If situations occur which are not covered in this manual, use care and good judgement. Contact Customer Support for assistance and the name of the nearest service dealer.

Maintenance & Storage

1. Never tamper with safety devices. Check their proper operation regularly.
2. Check bolts and screws for proper tightness at frequent intervals to keep the machine in safe working condition. Also, visually inspect machine for any damage and repair, if needed.

3. Before cleaning, repairing, or inspecting, stop the engine and make certain the impeller and all moving parts have stopped. Disconnect the spark plug wire and ground it against the engine to prevent unintended starting.
4. Do not change the engine governor settings or overspeed the engine. The governor controls the maximum safe operating speed of the engine.
5. Maintain or replace safety and instruction labels, as necessary.
6. Follow this manual for safe loading, unloading, transporting, and storage of this machine.
7. Never store the machine or fuel container inside where there is an open flame, spark or pilot light such as a water heater, furnace, clothes dryer, etc.
8. Allow machine to cool at least 5 minutes before storing.
9. Always refer to the operator's manual for proper instructions on off-season storage.
10. If the fuel tank has to be drained, do this outdoors.
11. Observe proper disposal laws and regulations for gas, oil, etc. to protect the environment.
12. According to the Consumer Products Safety Commission (CPSC) and the U.S. Environmental Protection Agency (EPA), this product has an *Average Useful Life* of seven (7) years, or 60 hours of operation. At the end of the *Average Useful Life* have the machine inspected annually by an authorized service dealer to ensure that all mechanical and safety systems are working properly and not worn excessively. Failure to do so can result in accidents, injuries or death.

Do not modify engine

To avoid serious injury or death, do not modify engine in any way. Tampering with the governor setting can lead to a runaway engine and cause it to operate at unsafe speeds. Never tamper with factory setting of engine governor.

Notice Regarding Emissions

Engines which are certified to comply with California and federal EPA emission regulations for SORE (Small Off Road Equipment) are certified to operate on regular unleaded gasoline, and may include the following emission control systems: Engine Modification (EM), Oxidizing Catalyst (OC), Secondary Air Injection (SAI) and Three Way Catalyst (TWC) if so equipped.

Spark Arrestor







WARNING: This machine is equipped with an internal combustion engine and should not be used on or near any unimproved forest-covered, brushcovered or grass-covered land unless the engine's exhaust system is equipped with a spark arrestor meeting applicable local or state laws (if any).

If a spark arrestor is used, it should be maintained in effective working order by the operator. In the State of California the above is required by law (Section 4442 of the California Public Resources Code). Other states may have similar laws. Federal laws apply on federal lands.

A spark arrestor for the muffler is available through your nearest engine authorized service dealer or contact the service department, P.O. Box 361131 Cleveland, Ohio 44136-0019.

Safety Symbols

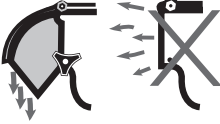
This page depicts and describes safety symbols that may appear on this product. Read, understand, and follow all instructions on the machine before attempting to assemble and operate.

Symbol	Description
	READ THE OPERATOR'S MANUAL(S) Read, understand, and follow all instructions in the manual(s) before attempting to assemble and operate
	WARNING— ROTATING BLADES Keep hands out of inlet and discharge openings while machine is running. There are rotating blades inside
	BYSTANDERS Keep bystanders, pets, and children at least 75 feet from the machine while it is in operation. Stop machine if anyone enters the area.
	WARNING— THROWN DEBRIS Never operate without the chute deflector properly attached to the machine.
	EYE PROTECTION Always wear safety glasses or safety goggles when operating this machine.



WARNING: Your Responsibility—Restrict the use of this power machine to persons who read, understand and follow the warnings and instructions in this manual and on the machine.

SAVE THESE INSTRUCTIONS!

Contents of Carton

- One Chipper Shredder
- One Operator's Manual
- One Engine Operator's Manual
- One Tow Bar
- One Bag
- One Safety Glasses
- One Bottle of Oil

Assembly

NOTE: This unit is shipped without gasoline or oil in the engine. Fill up gasoline and oil as instructed in the accompanying engine manual BEFORE operating your chipper shredder.

Chipper Chute (Model Series CS 3210 Only)

For shipping reasons, the unit is crated with its chipper chute in a raised position. To pivot it downward, proceed as follows:

1. Pull the spring latch upward.
2. Gently pivot the chipper chute down until it clicks into the lock rod. See Fig. 3-1.

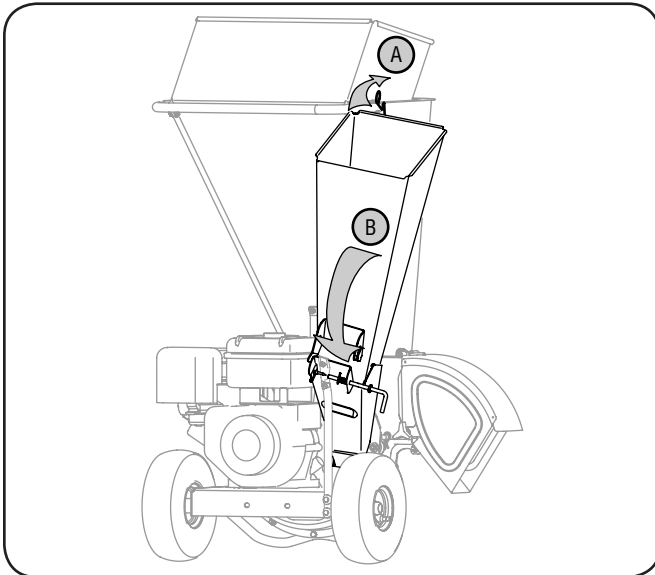

Figure 3-1



WARNING: Never operate the chipper shredder with the chipper chute in the raised position. Doing so may result in property damage or serious injury to the operator or bystanders.

Bag

To attach the bag:

1. Place the opening of the bag completely over the chute deflector. See Fig. 3-2.

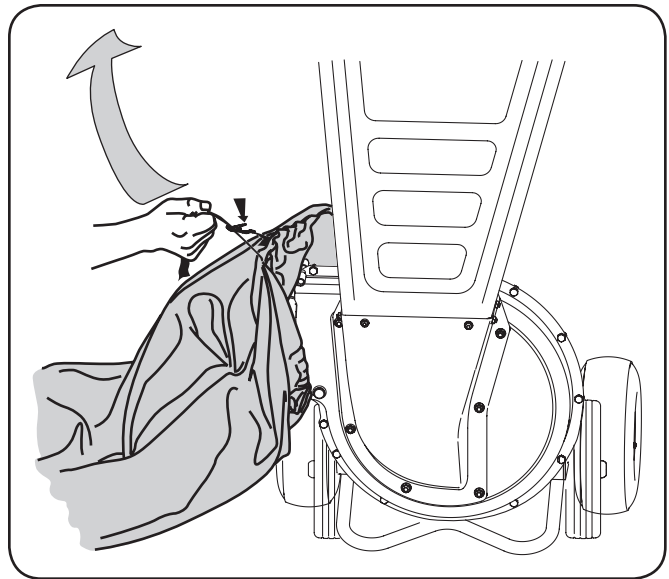

Figure 3-2

2. Position the bag so that the wing knobs which secure the chute deflector to the impeller housing are completely covered.
3. Pull on the draw-strap until the bag is tight around chute deflector opening.

Tow Bar

To attach the tow bar:

1. Remove the spring pin and clevis pin from the end of the tow bar receiver. See Fig. 3-3.

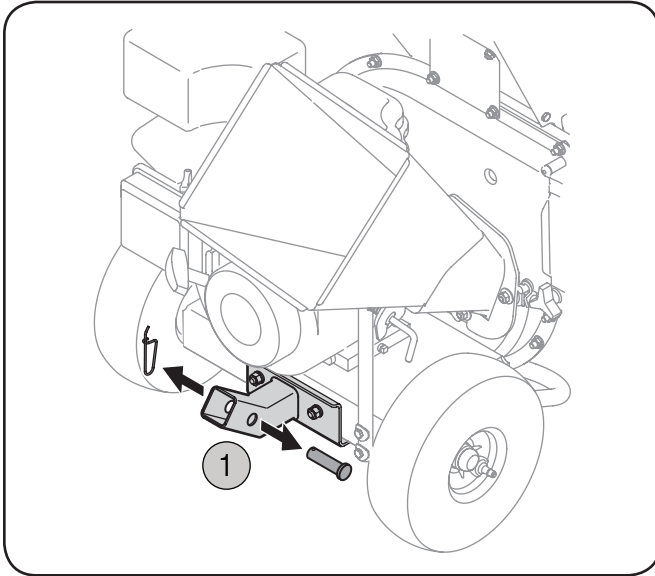

Figure 3-3

2. Insert the tow bar into the receiver.
3. Reinsert the clevis pin through aligning holes in both the tow bar and the receiver.
4. Fasten with the spring pin to secure. See Fig. 3-4.

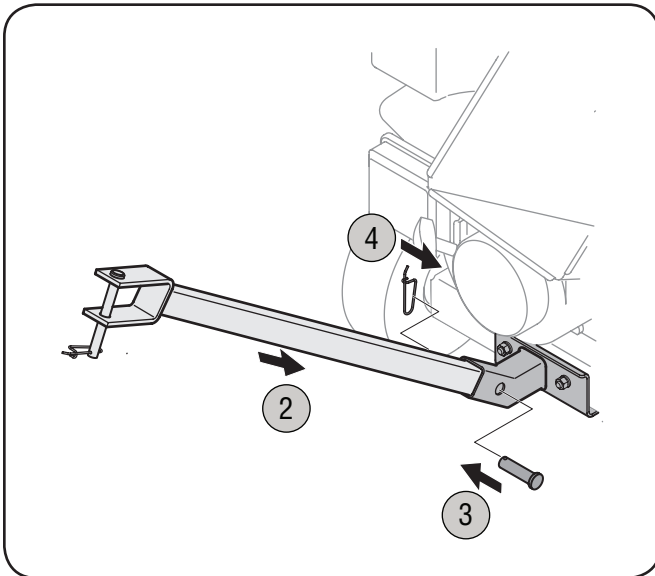

Figure 3-4

Set-Up

Gas and Oil Fill-Up

Refer to the separate engine owner's manual for additional engine information.

1. Add oil provided before starting unit for the first time out of the box.
2. Service the engine with gasoline as instructed in the separate engine owner's manual.



WARNING: Use extreme care when handling gasoline. Gasoline is extremely flammable and the vapors are explosive. Never fuel the machine indoors or while the engine is hot or running. Extinguish cigarettes, cigars, pipes and other sources of ignition.



WARNING: Never fill fuel tank indoors with engine running or until the engine has been allowed to cool for at least two minutes after running.

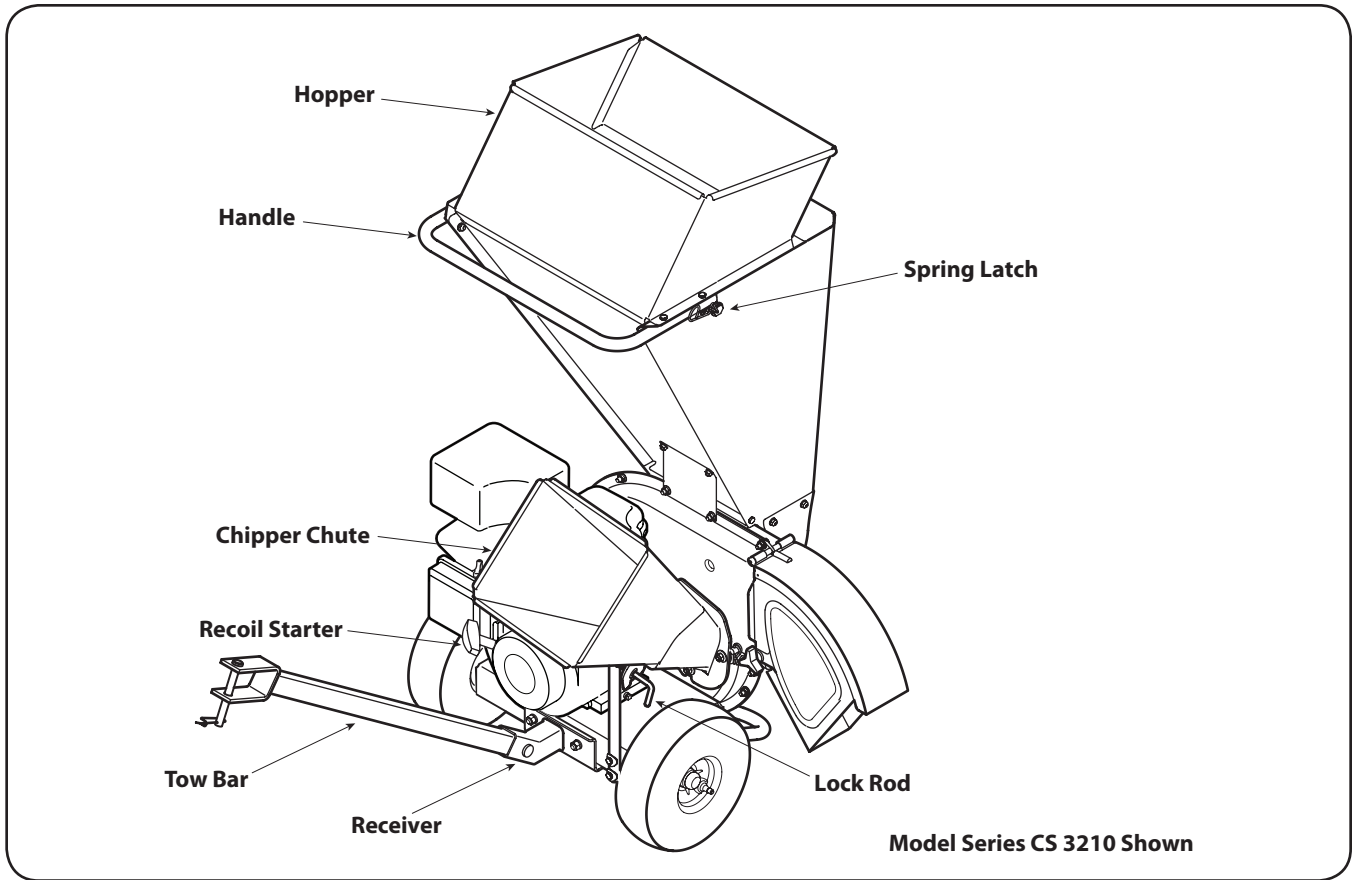

Figure 4-1

Chipper Chute

Branches up to two inches (model series CS 2210) or three inches (model series CS 3210) in diameter may be fed into the chipper chute for chipping.

Hopper

Leaves, twigs, and branches up to 1/2-inch in diameter may be placed into the hopper for shredding. See Fig. 4-1.

IMPORTANT: Never place branches with a diameter greater than 1/2-inch in the hopper. Doing so can result in serious damage to your unit's shredder blade, flails or impeller.

Tow Bar

Use the tow bar to tow the chipper shredder behind a tractor to a job site.

Handle

Use the handle when manually transporting the chipper shredder.

Recoil Starter

The recoil starter is located on the engine. Pull the recoil starter to start engine.

Engine Controls

See the engine Owner/Operator manual packed with your unit for the location and function of the controls on the engine.

Spring Latch (Model Series CS 3210 Only)

The spring latch is located on the top of the hopper. It is used to release or lock the chipper chute in a raised position for storage or for transporting. See Fig. 4-1.



WARNING: Never operate the chipper shredder with the chipper chute in the raised position. Use the spring latch to lower the chipper chute into the operating position before starting the engine.

Lock Rod (Model Series CS 3210 Only)

The lock rod is located on the chipper chute support. It is used to release or lock the chipper chute in a lowered position for operation.



WARNING: The operation of any chipper shredder can result in foreign objects being thrown into the eyes, which can damage your eyes severely. Always wear the safety glasses provided with this unit or eye shields before chipping or shredding and while performing any adjustments or repairs.

Starting Engine

IMPORTANT: Because this manual covers several different model units, different starting instructions may apply to your particular engine. Some engines may have a fuel petcock, some may not. Some engines may have On/Off switches, other may not. Some units will utilize a choke system, while others will require priming. These factors depend on what make and model engine comes with your particular unit. For these reasons, please refer to the Engine Operator's Manual for the correct starting procedure.

Basic Starting Procedure:

1. Attach spark plug wire to spark plug. Make certain the metal cap on the end of the spark plug is fastened securely over metal tip on the spark plug.
2. Open fuel shut-off valve (if equipped) and make sure the On/Off switch is in the On position (if equipped).
3. Move choke control lever to CHOKE position, if equipped. See Fig. 5-1. If the unit has a primer, prime the motor as instructed in the Engine Operator's Manual.

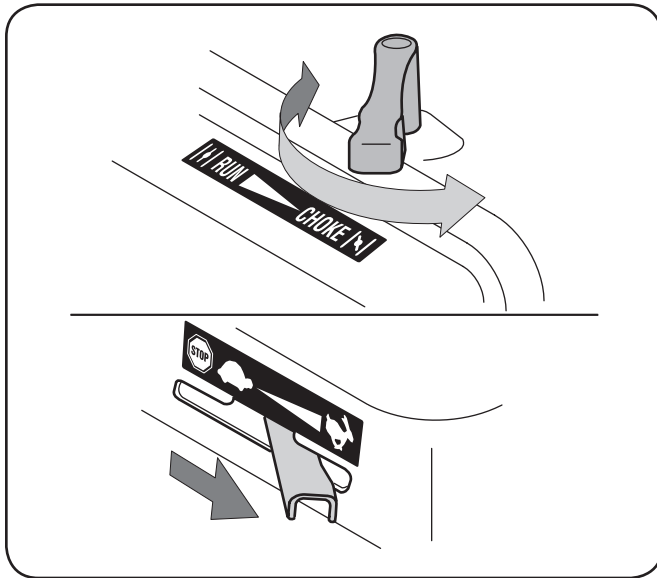

Figure 5-1

NOTE: A warm engine may not require choking or priming.

4. Move throttle control lever to FAST position (if equipped). See Fig. 5-1.
5. Grasp starter handle and pull rope out slowly until engine reaches start of compression cycle (rope will pull slightly harder at this point).

NOTE: A "clanking" noise may be heard when pulling the starter rope. It is completely normal and does NOT indicate a malfunction of any kind.

6. Pull rope with a rapid, continuous, full arm stroke. Keep a firm grip on starter handle. Let rope rewind slowly.
7. Repeat the previous steps until engine starts. When engine starts, move choke control gradually to RUN position until the engine is running smoothly.



WARNING: Never run the engine indoors or in a poorly ventilated area. Engine exhaust contains carbon monoxide, an odorless and deadly gas.

Stopping Engine

1. Move throttle control lever to STOP position (if equipped) or push rocker switch to OFF. See Fig. 5-2.

NOTE: See your Engine Operator's Manual packed with your unit for more detailed instructions.

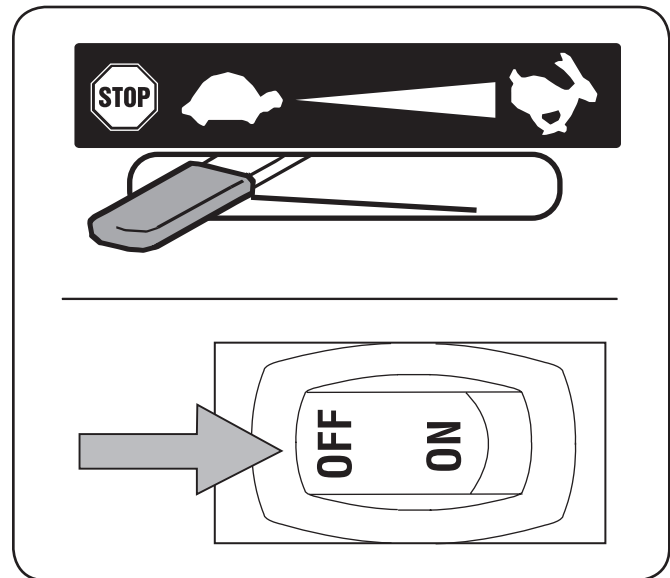

Figure 5-2



CAUTION: Never stop the engine by moving the choke lever into the CHOKE position. Backfire, fire or engine damage could result.

Shredding

Yard waste such as leaves and pine needles can be placed in the hopper for shredding. After material has been processed by the shredder blade and flails, it will be forced out of the chute deflector, and, if attached, into a debris collection bag.

Observe the following guidelines when shredding yard debris:

- Never attempt to shred material other than normal yard debris (leaves, twigs, pine cones, etc.).
- Avoid shredding fibrous plants such as tomato vines until they are thoroughly dried out. Fresh vines do not shred well and tend to wrap themselves around the impeller and flails.
- Place reasonable amounts of debris into the hopper at a time. Do not overload the hopper.
- Allow the material in the hopper to be drawn into the blades and shredded before adding additional debris to the hopper. Failure to do so may result in a clogged hopper, clogged chute deflector or a stalled engine.
- Avoid placing twigs longer than 24 inches into the hopper. Twigs longer than 24 inches may result in a clogged hopper.

IMPORTANT: Never place branches with a diameter greater than 1/2-inch in the hopper. Doing so can result in serious damage to the unit's shredder blade, flails or impeller.

Clearing the Hopper

Should the hopper become clogged with debris during operation, proceed as follows:

1. Grasp the handle with both hands and gently agitate the chipper shredder to help loosen debris, drawing it into the impeller.

If the clog does not clear, proceed as follows:

1. Stop engine.
2. Use your hands to remove any debris found near the top of the hopper.
3. Use a branch (or other available device, i.e. broomstick) to dislodge debris located toward the base of the hopper.
4. Restart engine.

NOTE: If you're unable to pull the starter rope as a result of accumulated debris near the impeller, follow instructions under the heading Cleaning the Reduction Chamber in the "Maintenance & Adjustments" section of this manual.

Chipping



WARNING: Never operate the chipper shredder without chipper chute lowered into the operating position.

Branches up to two inches (model series 410) or three inches (model series 420) in diameter can be fed into the chipper chute. Observe the following guidelines when chipping branches:

- Keep both hands firmly on the branch as you feed it into the chipper chute.
- Never feed more than one branch into the chipper chute at a time.
- Never feed anything other than branches (or wood) into the chipper chute.
- Apply intermittent pressure (force, in short pulses) while feeding larger branches into the chipper chute, to avoid bogging or stalling the engine.

IMPORTANT: Never feed branches with a diameter greater than two (2) inches (Model Series 410) or three (3) inches (model series 420) into the chipper chute. Doing so can result in serious damage to your unit's chipper blades, flails or impeller.

NOTE: For best performance, always operate the unit with sharp chipper blades. If a noticeable loss in performance is encountered while chipping branches, the chipper blades should be replaced.

Emptying the Bag

1. Stop engine.
2. Squeeze the locking buckle to release the bag's draw-strap before loosening it from the chute deflector. See Fig. 5-3.

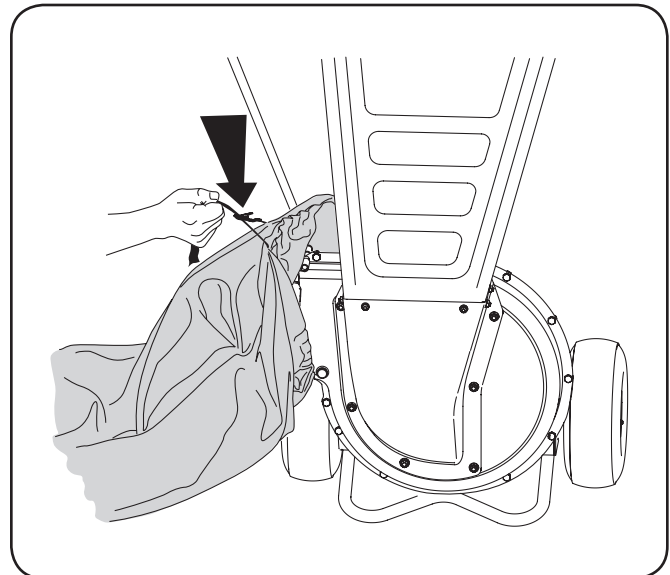

Figure 5-3

3. Empty the bag and reattach to the chute deflector opening. Refer to the "Set-Up & Adjustments" section of this manual.

Maintenance

General Recommendations

- Always observe safety rules when performing any maintenance.
- The warranty on this chipper shredder does not cover items that have been subjected to operator abuse or negligence. To receive full value from warranty, operator must maintain the equipment as instructed here.
- Changing of engine-governed speed will void engine warranty.
- All adjustments should be checked at least once each season.
- Periodically check all fasteners and make sure these are tight.



WARNING: Always stop engine, disconnect spark plug, and ground against engine before, cleaning, lubricating, or performing any type of maintenance on your machine.

Lubrication

1. Lubricate the chipper chute hinge with light oil once a season.
2. Lubricate the pivot points on the chute deflector with light oil once a season.
3. Follow the separate engine manual packed with your unit for engine lubrication instructions.

Equipment Care

- Clean the chipper shredder thoroughly after each use.
- Wash bag periodically with water. Allow to dry thoroughly in shade.
- If the reduction chamber becomes clogged, remove and clean as instructed below.

NOTE: Cleaning with a forceful spray of water is not recommended as it could contaminate the fuel system.

Engine Care

Refer to the Maintenance section of the Engine Operator's manual packed with your unit. Read and follow instructions carefully.

- Check engine oil level before each use as instructed in the separate engine manual.
- Clean or replace air cleaner every 25 hours under normal conditions. Clean every few hours under extremely dusty conditions. To service the air cleaner, refer to the engine manual.
- The spark plug should be cleaned and the gap reset once a season. Check engine manual for correct plug type and gap specifications.
- Clean engine regularly with a cloth or brush. Keep the top of the engine clean to permit proper air circulation. Remove all grass, dirt, and combustible debris from muffler area.

Cleaning The Reduction Chamber



WARNING: The impeller's shredder blade and chipper blades are sharp. Wear leather work gloves to protect your hands when cleaning out the reduction chamber.

If the reduction chamber becomes clogged with debris, the shredder screen can be pivoted upward so that you can clean the surrounding area. To do so, proceed as follows:

1. Stop engine, disconnect spark plug, and make certain the chipper shredder has come to a complete stop.



WARNING: The muffler and surrounding area will be hot if the engine has been running. Use caution and protect your hands if working near the muffler.

2. If attached, remove debris bag. Remove the two wing knobs on either side of the chute deflector and pivot the chute deflector upward. See Fig. 6-1A.

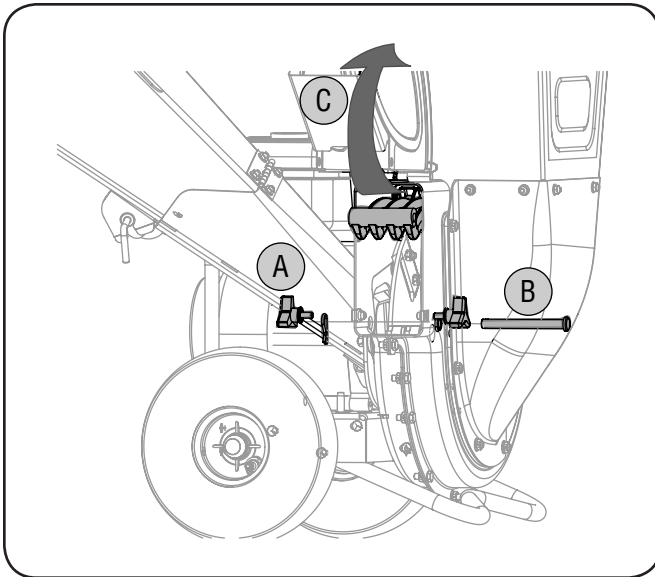

Figure 6-1

3. Remove the hairpin clip from the clevis pin which extends through the housing and shredder screen. See Fig. 6-1B. Remove clevis pin.
4. Pivot the shredder screen upward. See Fig. 6-1C. Clean the surrounding area by scraping away debris.
5. Confirm that the spark plug wire is disconnected and away from spark plug. Pull on the starter rope two-to-three times to purge any remaining debris from the reduction chamber.
6. When the area is cleaned, pivot the shredder screen downward and re-secure with the clevis pin and hairpin clip removed earlier.
7. Reattach the debris collection bag to the chute deflector, if desired.

Blade Care

Chipper Blades



WARNING: The impeller's chipper blades are sharp. Wear leather work gloves to protect your hands.

1. Stop engine, disconnect spark plug, and make certain the chipper shredder has come to a complete stop.
2. Pivot the shredder screen upward as instructed under the heading Cleaning the Reduction Chamber.
3. Remove the chipper chute support brace from the frame by removing the two hex bolts and saddle washers which secure it. See Fig. 7-1A.

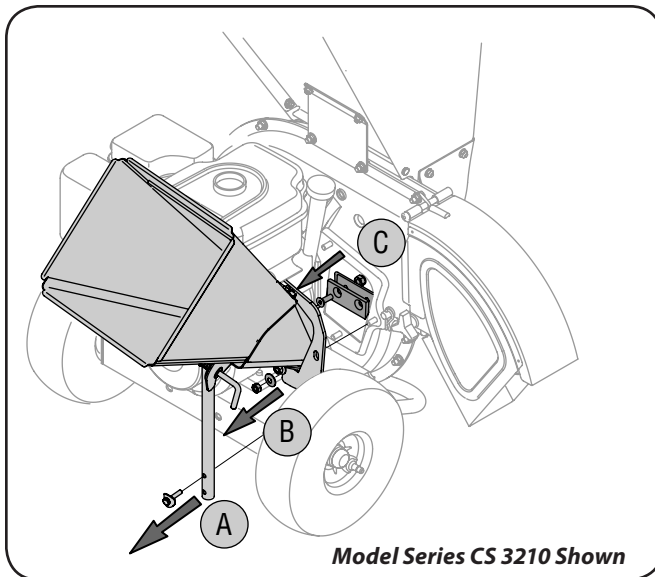

Figure 7-1

4. Remove the chipper chute by removing three hex nuts and washers which secure it to the impeller housing. See Fig. 7-1B.
5. Rotate the impeller by hand until one of the two chipper blades is visible through the impeller housing opening.
6. Remove the blade by removing the internal hex screws, lock washers and hex nuts which secure it to the impeller. See Fig. 7-1C. Retain the hardware.

NOTE: Use a 3/16" hex key (Allen) wrench on the outside of the blade and a 1/2" box (or socket) wrench on the inside of the impeller. Hold the Allen wrench stationary and rotate the box (or socket) wrench to loosen the nut.

7. Install a replacement blade (Part No. 742-0544) with the hardware removed earlier or sharpen.

IMPORTANT: When sharpening the blade, protect hands by using gloves. Follow the original angle of grind and make sure to remove an equal amount from each blade.

8. To replace the other blade, rotate the impeller to expose the second blade and repeat the steps above.

NOTE: Make certain blades are reassembled with the sharp edge outward (toward the chipper chute). Torque hardware to between 20 ft.-lbs and 25 ft.-lbs.

Shredder Blade



WARNING: The shredder blade is sharp. Wear leather work gloves to protect your hands.

1. Stop engine, disconnect spark plug, and make certain that all moving parts have come to a complete stop.
2. Remove the two flange nuts (and hex bolts) which secure the hopper support bracket to the impeller housing. Retain the hardware. See Fig. 7-2.

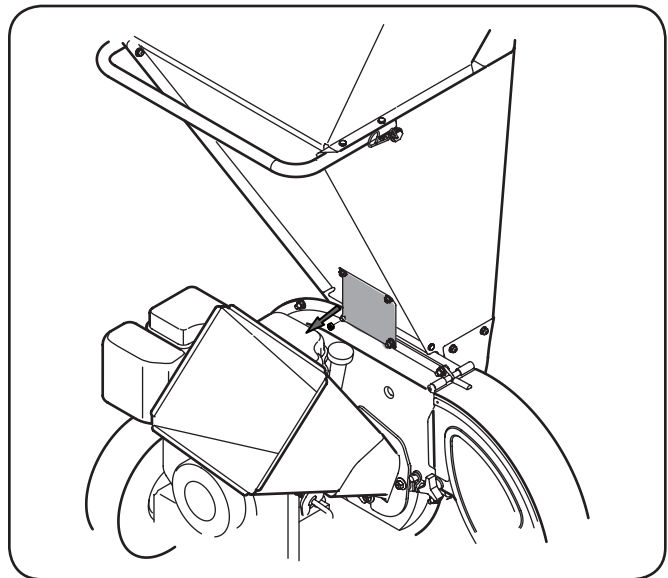

Figure 7-2

3. Pivot the shredder screen upward as instructed under the heading Cleaning the Reduction Chamber.

- Remove six flange nuts which secure hopper inlet guide to impeller housing. See Fig. 7-3A.

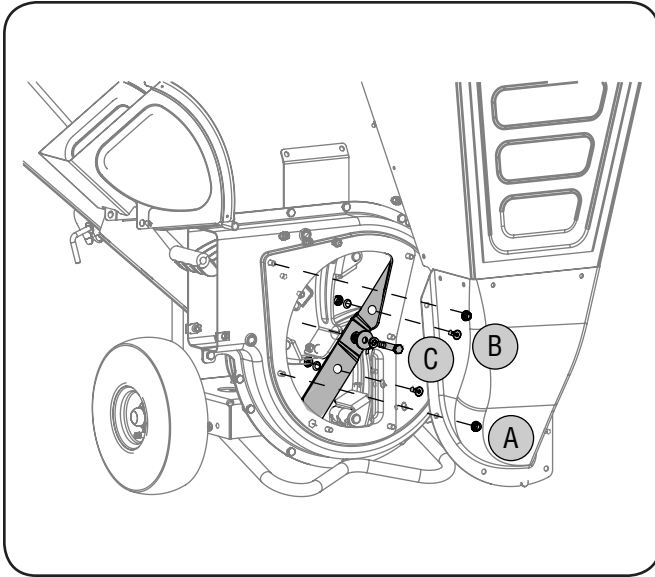

Figure 7-3

- Carefully separate the hopper assembly from the impeller housing and set it aside.
- Insert a piece of wood into the chute deflector opening to stabilize the impeller and prevent it from rotating when removing the shredder blade.

- Remove the two internal hex screws, hex lock nuts, and lock washers which secure the shredder blade to the impeller. See Fig. 7-3B.

NOTE: Use a 3/16" hex key (Allen) wrench on the outside of the shredder blade and a 1/2" box (or socket) wrench on the inside of the shredder blade. Hold the Allen wrench stationary and rotate the box (or socket) wrench to loosen the nut.

- Remove the hex bolt, lock washer, and flat washer to completely free shredder blade. See Fig. 7-3C.

IMPORTANT: If sharpening the blade for reuse, follow the original angle of grind as a guide. Make certain each cutting edge receives an equal amount of grinding to prevent an unbalanced blade. Remove metal from the heavy side until it is balanced evenly.

IMPORTANT: When reassembling the blade, tighten center bolt to between 45 ft.-lbs and 58 ft.-lbs and the two out bolts to between 20 ft.-lbs and 25 ft.-lbs.

Off-Season Storage

- Allow the unit to run and clear out all debris for a short time before shutting the unit down before storage.
- When storing the chipper shredder in an unventilated or metal storage shed, care should be taken to rustproof the non-painted surfaces. Using a light oil or silicone, coat the equipment, especially any springs, bearings, and cables.
- Remove all dirt from exterior of engine and equipment.
- Follow lubrication recommendations.
- Refer to engine manual for correct engine storage instructions.
- Store equipment in a clean, dry area. Do not store in an area where equipment is present that may use a pilot light or has a component that can create a spark.

Problem	Cause	Remedy
Engine Fails to start	<ol style="list-style-type: none"> 1. Throttle lever not in correct starting position. 2. Spark plug wire disconnected. 3. Choke not in CHOKE position (if equipped). 4. Fuel tank empty or stale fuel. 5. Engine not primed (if equipped). 6. Faulty spark plug. 7. Blocked fuel line. 8. Engine flooded. 	<ol style="list-style-type: none"> 1. Move throttle lever to FAST or START position. 2. Connect wire to spark plug. 3. Move choke lever to CHOKE position. 4. Fill tank with clean, fresh gasoline. 5. Prime engine as instructed in Engine Manual. 6. Clean, adjust gap, or replace. 7. Clean fuel line. 8. Wait a few minutes to restart, but do not prime.
Engine runs erratic	<ol style="list-style-type: none"> 1. Spark plug boot loose. 2. Unit running on CHOKE (if equipped). 3. Blocked fuel line or stale fuel. 4. Low engine RPM. 5. Water or dirt in fuel system. 6. Dirty air cleaner. 7. Carburetor out of adjustment. 	<ol style="list-style-type: none"> 1. Connect and tighten spark plug boot. 2. Move choke lever to OFF position. 3. Clean fuel line; fill tank with clean, fresh gasoline. 4. Always run engine at full throttle. 5. Drain fuel tank. Refill with fresh fuel. 6. Refer to engine manual. 7. See authorized service dealer.
Engine overheats	<ol style="list-style-type: none"> 1. Engine oil level low. 2. Dirty air cleaner. 3. Carburetor not adjusted properly. 	<ol style="list-style-type: none"> 1. Fill crankcase with proper oil. 2. Refer to engine manual. 3. See authorized service dealer.
Occasional skips (hesitates) at high speed	<ol style="list-style-type: none"> 1. Spark plug gap too close. 2. Carburetor idle mixture adjustment improperly set. 	<ol style="list-style-type: none"> 1. Remove spark plug and adjust gap to .030". 2. See authorized service dealer.
Excessive Vibration	<ol style="list-style-type: none"> 1. Loose parts or damaged impeller. 	<ol style="list-style-type: none"> 2. See authorized service dealer.
Unit does not discharge	<ol style="list-style-type: none"> 1. Discharge area clogged. 2. Foreign object lodged in impeller. 3. Low engine RPM. 	<ol style="list-style-type: none"> 1. Stop engine immediately and disconnect spark plug wire. Clean flail screen and inside of discharge opening. 2. Stop engine and disconnect spark plug wire. Remove lodged object. 3. Always run engine at full throttle.
Rate of discharge slows considerably or composition of discharged material changes	<ol style="list-style-type: none"> 1. Low engine RPM. 2. Chipper blade dull. 	<ol style="list-style-type: none"> 1. Always run engine at full throttle. 2. Replace chipper blade or see your authorized service dealer.

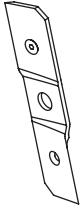
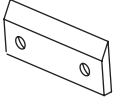
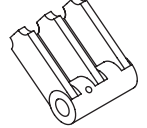
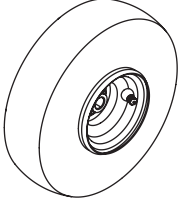
Component	Part Number and Description
	942-04050 Shredder Blade
	942-0544B Chipper Blade
	719-04308 Flail Blade (3 total)
	634-04627 10 x 4.0 Pneumatic Wheel with Bearings

Phone (800) 965-4CUB to order replacement parts or a complete Parts Manual (have your full model number and serial number ready). Parts Manual downloads are also available free of charge at www.cubcadet.com.

CUB CADET LLC
MANUFACTURER'S LIMITED WARRANTY FOR
CHIPPER-SHREDDERS & CHIPPER-SHREDDER VACUUMS

The limited warranty set forth below is given by Cub Cadet LLC with respect to new merchandise purchased and used in the United States, its possessions and territories, and by MTD Products Limited with respect to new merchandise purchased and used in Canada and/or its territories and possessions.

"Cub Cadet" warrants this product (excluding its *Normal Wear Parts* as described below) against defects in material and workmanship for a period of three (3) years commencing on the date of original purchase and will, at its option, repair or replace, free of charge, any part found to be defective in materials or workmanship. This limited warranty shall only apply if this product has been operated and maintained in accordance with the Operator's Manual furnished with the product, and has not been subject to misuse, abuse, commercial use, neglect, accident, improper maintenance, alteration, vandalism, theft, fire, water, or damage because of other peril or natural disaster. Damage resulting from the installation or use of any part, accessory or attachment not approved by Cub Cadet for use with the product(s) covered by this manual will void your warranty as to any resulting damage.

Normal Wear Parts are warranted to be free from defects in material and workmanship for a period of thirty (30) days from the date of purchase. Normal wear parts include, but are not limited to items such as: belts, blades, debris collection bags, wheels and tires.

HOW TO OBTAIN SERVICE: Warranty service is available, WITH PROOF OF PURCHASE, through your local authorized service dealer. To locate the dealer in your area:

In the U.S.A.

To locate the dealer in your area, check your Yellow Pages, or contact Cub Cadet LLC at P.O. Box 361131, Cleveland, Ohio 44136-0019, call 1-877-282-8684, or log on to our Web site at www.cubcadet.com.

In Canada

Contact MTD Products Limited, Kitchener, ON N2G 4J1, call 1-800-668-1238 or log on to our Web site at www.mtdcanada.com.

This limited warranty does not provide coverage in the following cases:

- a. The engine or component parts thereof. These items may carry a separate manufacturer's warranty. Refer to applicable manufacturer's warranty for terms and conditions.
- b. Log splitter pumps, valves, and cylinders have a separate one year warranty.
- c. Routine maintenance items such as lubricants, filters, blade sharpening, tune-ups, brake adjustments, clutch adjustments, deck adjustments, and normal deterioration of the exterior finish due to use or exposure.

- d. Cub Cadet does not extend any warranty for products sold or exported outside of the United States and/or Canada, and their respective possessions and territories, except those sold through Cub Cadet's authorized channels of export distribution.
- e. Replacement parts that are not genuine Cub Cadet parts.
- f. Service completed by someone other than an authorized service dealer.
- g. Transportation charges and service calls.
- h. Cub Cadet does not warrant this product for commercial use.

No implied warranty, including any implied warranty of merchantability of fitness for a particular purpose, applies after the applicable period of express written warranty above as to the parts as identified. No other express warranty, whether written or oral, except as mentioned above, given by any person or entity, including a dealer or retailer, with respect to any product, shall bind Cub Cadet. During the period of the warranty, the exclusive remedy is repair or replacement of the product as set forth above.

The provisions as set forth in this warranty provide the sole and exclusive remedy arising from the sale. Cub Cadet shall not be liable for incidental or consequential loss or damage including, without limitation, expenses incurred for substitute or replacement lawn care services or for rental expenses to temporarily replace a warranted product.

Some states do not allow the exclusion or limitation of incidental or consequential damages, or limitations on how long an implied warranty lasts, so the above exclusions or limitations may not apply to you.

In no event shall recovery of any kind be greater than the amount of the purchase price of the product sold. **Alteration of safety features of the product shall void this warranty.** You assume the risk and liability for loss, damage, or injury to you and your property and/or to others and their property arising out of the misuse or inability to use the product.

This limited warranty shall not extend to anyone other than the original purchaser or to the person for whom it was purchased as a gift.

HOW STATE LAW RELATES TO THIS WARRANTY: This limited warranty gives you specific legal rights, and you may also have other rights that vary in different jurisdictions.

IMPORTANT: Owner must present Original Proof of Purchase to obtain warranty coverage.

Cub Cadet LLC, P.O. BOX 361131 CLEVELAND, OHIO 44136-0019; Phone: 1-877-282-8684
MTD Canada Limited - KITCHENER, ON N2G 4J1; Phone 1-800-668-1238