

# Supplement Sheet

Date: November 20, 2012  
Subject: Lap Bar Hardware  
Model(s): All 2013 RZT

## Contents

Contents of this bag are listed below. Part numbers are shown in parentheses.

- Two Hex Screws (710-1880)
- Two Flat Washers (736-3008)

## Securing the Lap Bars

In addition to the assembly steps found in your RZT's Operator's Manual, follow the steps below to secure the lap bars in place.

1. Pivot the right lap bar upward and fasten it to the mounting bracket with a hex screw and flat washer. Refer to Figure 1-1. Do *not* tighten at this time.
2. Repeat Step 1 on the left lap bar.
3. Pivot the lap bars into the desired operating position.
4. Using a ½-inch wrench, tighten the screw on the right side to secure the lap bar in place.
5. Align the left lap bar with the right lap bar. Tighten the screw on the left side to secure the lap bar in place.



**CAUTION:** Torque the screws down tightly to prevent the lap bars from slipping out of position.

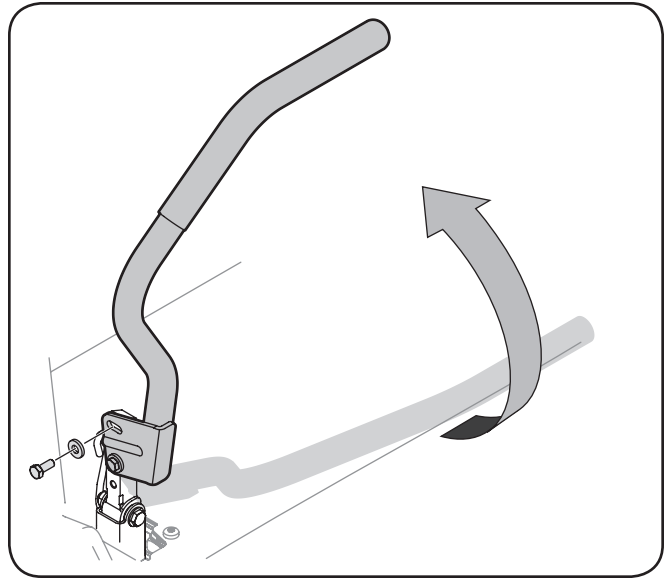

Figure 1-1

---

MTD LLC, P.O. BOX 361131 CLEVELAND, OHIO 44136-0019

---