



# OPERATOR'S MANUAL

## Pony, Pony ES & Pro-Line FRT Tiller

### Record Product Information

Before setting up and operating your new equipment, please locate the model plate and record the information in the area provided to the right. The model plate contains the unit's model and serial numbers. This information will be necessary, should you seek technical support via our web site, Customer Support Department, or with a local authorized service dealer.

### MODEL NUMBER

--	--	--	--	--	--	--	--	--	--	--	--

### SERIAL NUMBER

--	--	--	--	--	--	--	--	--	--	--	--

### Table of Contents

<i>Safe Operation Practices</i> .....	3	<i>Troubleshooting</i> .....	12
<i>Assembly &amp; Set-Up</i> .....	5	<i>Replacement Parts</i> .....	13
<i>Controls &amp; Operation</i> .....	7	<i>Warranty</i> .....	16
<i>Service</i> .....	10		

**⚠ WARNING**

Read and follow all safety rules and instructions in this manual before attempting to operate this machine. Failure to comply with these instructions may result in personal injury.

**⚠ WARNING**

**California Proposition 65**

Engine Exhaust, some of its constituents, and certain vehicle components contain or emit chemicals known to the State of California to cause cancer and birth defects.

**NOTE:** This Operator's Manual covers several models. Features may vary by model. Not all features in this manual are applicable to all models and the model depicted may differ from yours.



# TO THE OWNER

## Thank You

Thank you for purchasing this product. It was carefully engineered to provide excellent performance when properly operated and maintained.

Please read this entire manual prior to operating the equipment. It instructs you how to safely and easily set up, operate and maintain your machine. Please be sure that you, and any other persons who will operate the machine, carefully follow the recommended safety practices at all times. Failure to do so could result in personal injury or property damage.

All information in this manual is relative to the most recent product information available at the time of printing. Review this manual frequently to familiarize yourself with the machine, its features and operation. Please be aware that this Operator's Manual may cover a range of product specifications for various models. Characteristics and features discussed and/or illustrated in this manual may not be applicable to all models. We reserve the right to change product specifications, designs and equipment without notice and without incurring obligation.

If applicable, the power testing information used to establish the power rating of the engine equipped on this machine can be found at [www.opei.org](http://www.opei.org) or the engine manufacturer's web site.

If you have any problems or questions concerning the machine, phone an authorized service dealer or contact us directly. Customer Support telephone number, website address and mailing address can be found on this page. We want to ensure your complete satisfaction at all times.

Throughout this manual, all references to *right* and *left* side of the machine are observed from the operating position.

---

## Customer Support

***Please do NOT return the machine to the retailer or dealer without first contacting the Customer Support Department.***

If you have difficulty assembling this product or have any questions regarding the controls, operation, or maintenance of this machine, want to order replacement parts/attachments/accessories, or want to view an online How-To video; you can seek help from the experts. Have your full model number and serial number ready. Choose from the options below:

- ◇ **Web:** [www.troybilt.com/equipment/troybilt](http://www.troybilt.com/equipment/troybilt)
- ◇ **Phone:** (800) 828-5500
- ◇ **Mail:** Troy-Bilt LLC • P.O. Box 361131 • Cleveland, OH • 44136-0019

# SAFE OPERATION PRACTICES

## ⚠ WARNING

⚠ This symbol points out important safety instructions which, if not followed, could endanger the personal safety and/or property of yourself and others. Read and follow all instructions in this manual before attempting to operate this machine. Failure to comply with these instructions may result in personal injury. When you see this symbol - HEED ITS WARNING!

## ⚠ DANGER

This machine was built to be operated according to the safe operation practices in this manual. As with any type of power equipment, carelessness or error on the part of the operator can result in serious injury. This machine is capable of amputating hands and feet and throwing debris. Failure to observe the following safety instructions could result in serious injury or death.

### Training

1. Read, understand and follow all instructions on the machine and in the manual(s) before attempting to assemble and operate. Keep this manual in a safe place for future and regular reference and for ordering replacement parts.
2. Be familiar with all controls and their proper operation. Know how to stop the machine and disengage it quickly.
3. Never allow children under 14 years of age to operate this machine. Children 14 and over should read and understand the instructions and safe operation practices in this manual and on the machine and be trained and supervised by an adult.
4. Never allow adults to operate this machine without proper instruction.
5. Keep the area of operation clear of all persons, particularly small children and pets. Stop machine if anyone enters the area.

### Preparation

1. Thoroughly inspect the area where the equipment is to be used. Remove all stones, sticks, wire and other foreign objects which could be tripped over and cause personal injury.
2. Wear sturdy, rough-soled work shoes and close fitting slacks and shirt. Loose fitting clothes or jewelry can be caught in moving parts. Never operate this machine in bare feet or sandals.
3. Disengage clutch levers and shift (if provided) into neutral ("N") before starting the engine.
4. Never leave this machine unattended with the engine running.
5. Never attempt to make any adjustments while engine is running, except where specifically recommended in the operator's manual.

### Safe Handling of Gasoline:

1. To avoid personal injury or property damage use extreme care in handling gasoline. Gasoline is extremely flammable and the vapors are explosive. Serious personal injury can occur when gasoline is spilled on yourself or your clothes which can ignite. Wash your skin and change clothes immediately.
  - Use only an approved gasoline container.
  - Never fill containers inside a vehicle or on a truck or trailer bed with a plastic liner. Always place containers on the ground away from your vehicle before filling.
  - When practical, remove gas-powered equipment from the truck or trailer and refuel it on the ground. If this is not possible, then refuel such equipment on a trailer with a portable container, rather than from a gasoline dispenser nozzle.
  - Keep the nozzle in contact with the rim of the fuel tank or container opening at all times until fueling is complete. Do not use a nozzle lock-open device.
  - Extinguish all cigarettes, cigars, pipes and other sources of ignition.
  - Never fuel machine indoors.
  - Never remove gas cap or add fuel while the engine is hot or running. Allow engine to cool at least five minutes before refueling.
  - Never over fill fuel tank. Fill tank to no more than 1/2 inch below bottom of filler neck to allow space for fuel expansion.
  - Replace gasoline cap and tighten securely.
  - If gasoline is spilled, wipe it off the engine and equipment. Move unit to another area. Wait five minutes before starting the engine.
  - To reduce fire hazards, keep machine free of grass, leaves or other debris build-up. Clean up oil or fuel spillage and remove any fuel soaked debris.
  - Never store the machine or fuel container inside where there is an open flame, spark or pilot light as on a water heater, space heater, furnace, clothes dryer or other gas appliances.

### Operation

1. Do not put hands or feet near rotating parts. Contact with the rotating parts can amputate hands and feet.
2. Always wear safety glasses or safety goggles during operation and while performing an adjustment or repair to protect your eyes. Thrown objects which ricochet can cause serious injury to the eyes.
3. For extended use of this product, hearing protection is required.
4. Do not operate machine while under the influence of alcohol or drugs.
5. Never operate this machine without good visibility or light. Always be sure of your footing and keep a firm hold on the handles.

6. Keep bystanders away from the machine while it is in operation. Stop the machine if anyone enters the area.
7. Be careful when tilling in hard ground. The tines may catch in the ground and propel the tiller forward. If this occurs, let go of the handle bars and do not restrain the machine.
8. Exercise extreme caution when operating on or crossing gravel surfaces. Stay alert for hidden hazards or traffic. Do not carry passengers.
9. Never operate the machine at high transport speeds on hard or slippery surfaces.
10. Exercise caution to avoid slipping or falling.
11. Look down and behind and use care when in reverse or pulling machine towards you.
12. Start the engine according to the instructions found in this manual and keep feet well away from the tines at all times.
13. After striking a foreign object, stop the engine, disconnect the spark plug wire and ground against the engine. Thoroughly inspect the machine for any damage. Repair the damage before starting and operating.
14. Disengage all clutch levers (if fitted) and stop engine before you leave the operating position (behind the handles). Wait until the tines come to a complete stop before unclogging the tines or making any adjustments or inspections.
15. Never run an engine indoors or in a poorly ventilated area. Engine exhaust contains carbon monoxide, an odorless and deadly gas.
16. Muffler and engine become hot and can cause a burn. Do not touch.
17. Use caution when tilling near fences, buildings and underground utilities. Rotating tines can cause property damage or personal injury.
18. Do not overload machine capacity by attempting to till soil too deep at too fast of a rate.
19. If the machine should start making an unusual noise or vibration, stop the engine, disconnect the spark plug wire and ground it against the engine. Inspect thoroughly for damage. Repair any damage before starting and operating.
20. Keep all shields, guards and safety devices in place and operating properly.
21. Never pick up or carry machine while the engine is running.
22. Use only attachments and accessories approved by the manufacturer. Failure to do so can result in personal injury.
23. If situations occur which are not covered in this manual, use care and good judgement. Contact Customer Support for assistance and the name of your nearest servicing dealer.

### Maintenance & Storage

1. Keep machine, attachments and accessories in safe working order.
2. Allow a machine to cool at least five minutes before storing. Never tamper with safety devices. Check their proper operation regularly.
3. Check bolts and screws for proper tightness at frequent intervals to keep the machine in safe working condition. Also, visually inspect machine for any damage.
4. Before cleaning, repairing or inspecting, stop the engine and make certain the tines and all moving parts have stopped. Disconnect the spark plug wire and ground it against the engine to prevent unintended starting.
5. Do not change the engine governor settings or over-speed the engine. The governor controls the maximum safe operating speed of engine.
6. Maintain or replace safety and instruction labels, as necessary.
7. Follow this manual for safe loading, unloading, transporting and storage of this machine.
8. Always refer to the Operator's Manual for important details if the machine is to be stored for an extended period.
9. If the fuel tank has to be drained, do this outdoors.
10. Observe proper disposal laws and regulations for gas, oil, etc. to protect the environment.
11. According to the Consumer Products Safety Commission (CPSC) and the U.S. Environmental Protection Agency (EPA), this product has an *Average Useful Life* of seven (7) years, or 130 hours of operation. At the end of the *Average Useful Life* have the machine inspected annually by an authorized service dealer to ensure that all mechanical and safety systems are working properly and not worn excessively. Failure to do so can result in accidents, injuries or death.

# SAFE OPERATION PRACTICES

## Notice Regarding Emissions

Engines which are certified to comply with California and federal EPA emission regulations for SORE (Small Off Road Equipment) are certified to operate on regular unleaded gasoline, and may include the following emission control systems: Engine Modification (EM), Oxidizing Catalyst (OC), Secondary Air Injection (SAI) and Three Way Catalyst (TWC) if so equipped.

## Spark Arrestor

### WARNING



**This machine is equipped with an internal combustion engine and should not be used on or near any unimproved forest-covered, brushcovered or grass-covered land unless the engine's exhaust system is equipped with a spark arrestor meeting applicable local or state laws (if any).**

If a spark arrestor is used, it should be maintained in effective working order by the operator. In the State of California the above is required by law (Section 4442 of the California Public Resources Code). Other states may have similar laws. Federal laws apply on federal lands.

A spark arrestor for the muffler is available through your nearest engine authorized service dealer or contact the service department, P.O. Box 361131 Cleveland, Ohio 44136-0019.

## Safety Symbols

This page depicts and describes safety symbols that may appear on this product. Read, understand and follow all instructions on the machine before attempting to assemble and operate.

Symbol	Description
	<b>READ THE OPERATOR'S MANUAL(S)</b> Read, understand and follow all instructions in the manual(s) before attempting to assemble and operate.
	<b>WARNING— ROTATING TINES</b> Do not put hands or feet near rotating parts. Contact with the rotating parts can amputate hands and feet.

### WARNING

**Your Responsibility — Restrict the use of this power machine to persons who read, understand and follow the warnings and instructions in this manual and on the machine.  
SAVE THESE INSTRUCTIONS!**

# ASSEMBLY & SET-UP

## Contents of Carton

- Tiller
- Handlebar Support
- Handlebar Assembly
- Hardware Pack
- Operator's Manual
- Engine Operator's Manual

**NOTE:** This Operator's Manual covers several garden tiller models. The tiller depicted may differ from yours.

### WARNING

To prevent personal injury or property damage, do not start the engine until all assembly steps are complete and you have read and understand the safety and operating instructions in this manual.

## Recommended Tools for Assembly

- Two 1/2" open-end wrenches
- Block of wood (to support tiller when removing wheels)
- Tire pressure gauge
- Clean oil funnel
- Motor oil. Refer to the Engine Operator's Manual for oil specifications and quantity required.

## Assembly

### Unpacking Instructions

**NOTE:** While unpacking, do not severely bend any of the control cables.

1. The tiller is heavy. You should not attempt to remove it from the shipping platform until instructed to do so.
2. Remove any cardboard inserts and packaging material from the carton. Remove any staples from the bottom of the carton and remove the carton.
3. Cut the large, plastic tie strap that secures the transmission tube to the shipping pallet. Leave the handlebars on top of the tiller to avoid damaging any cables.
4. The hardware bag is inside the literature envelope. Check the contents with the list above.

### Handle

**NOTE:** All references to the right or left side of the tiller are from the operator's position.

1. Remove the knob from the center of the lower end of the handle by rotating it counter-clockwise. See Figure 1.
2. Cut the large, plastic cable ties that secure the handlebar ends to the handlebar mounting tabs on the transmission top cover. Gently lift the handlebar (do not overstretch the attached cables) and place the handlebar cross-brace in front of the curved height adjustment bracket. See Figure 2.
3. With the forward clutch cable on the inside of the handlebar, position the handlebar ends on the outside of the two mounting tabs atop the transmission cover. See inset in Figure 2.

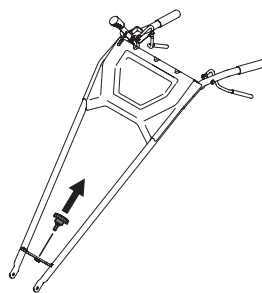

Figure 1

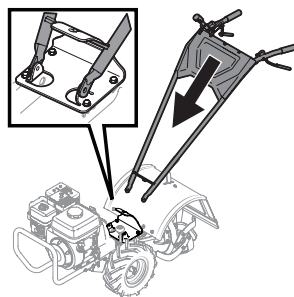

Figure 2

5. Loosely attach the handlebars to the mounting tabs with two shoulder screws (.437 x .268: 5/16 - 18), inserted through two Belleville washers (.450 x 1.0 x .062), then through the lower ends of the handle and the front holes on the bracket. Add flat washers (.349 x .879 x .063) on the ends of each and secure them by threading a hex lock nut (5/16-18) on each end. See Figure 3.
6. Make sure the handlebar cross-brace is under the bracket. Move the handlebars up or down to align the threaded hole in the cross brace with one of the three slots in the curved height adjustment bracket.
7. Thread the height adjustment knob through the washer (.760 x 1.250 x .041) then into the hole in the handlebar cross-brace. See Figure 4.
8. Securely tighten the height adjustment screw.
9. Securely tighten the shoulder screws and hex lock nuts from Step 5 on the ends of the handlebar.
10. To remove the tiller from its shipping platform, first carefully unwrap the wheel gear cable with the attached lever from around the chassis. Move the neutral ENGAGE/DISENGAGE lever to the DISENGAGE position. This allows the wheels to rotate freely.
11. Use the handlebars to roll the tiller off the platform.

**NOTE:** See Controls & Operation section for location and operation instructions.

**NOTE:** Use the DISENGAGE position to move tiller only when the engine is not running. Before starting the engine, the neutral ENGAGE/DISENGAGE lever must be placed in the ENGAGE position (see the Controls & Operation section for details).

### Reverse Clutch Control

1. Carefully unwrap the reverse clutch control cable (red) from its shipping position and route it up the right side handle. Position the cable so that it rests above the small groove on the handle assembly in front of the reverse drive handle. See Figure 5.
2. Insert the cable Z-connector into the slot in the control panel from the inside of the handle outward. See inset in Figure 5.
3. Snap the cable tab into place in the upper hole on the handle cable bracket. See Figure 6.

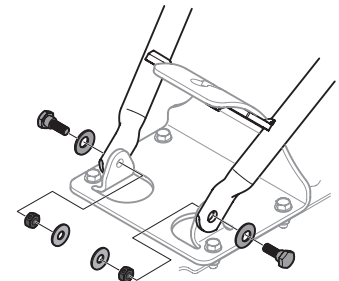

Figure 3

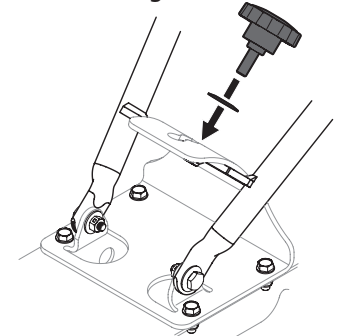

Figure 4

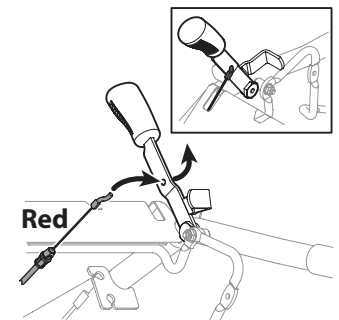

Figure 5

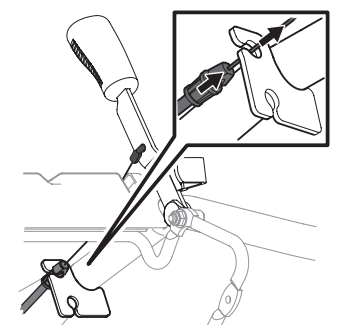

Figure 6

# ASSEMBLY & SET-UP

4. Test the function of the reverse clutch control cable by pulling the knob back and releasing it. The knob should return to its neutral position against the tapered bushing. If it does not return when released contact your local authorized dealer or Customer Support for technical assistance.

## Forward Clutch Cable

1. Carefully free the forward clutch control levers from their shipping position by removing any fasteners (rubber bands, tape, etc.) that may secure the forward clutch control levers during shipping.

**NOTE:** The control handles should hang beneath the handlebars.

2. The forward clutch control cable (black) is hanging loosely near the right-side wheel. Being careful not to kink or stretch the cable, route the cable on top of the lower handle and under the handle panel then insert the Z-connector into the hole at the end of the forward clutch control linkage going from the outside inward. See Figure 7.
3. Snap the cable tab into place in the lower hole on the handle cable bracket. See Figure 8.

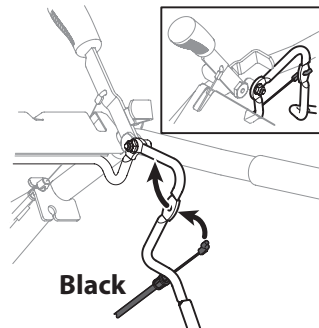

Figure 7

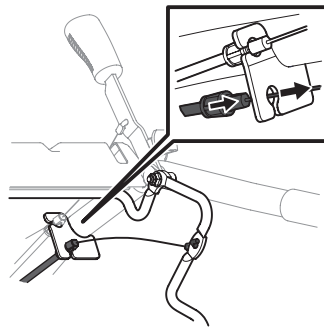

Figure 8

## Installing Emergency Stop Control (IF EQUIPPED)

### ⚠ WARNING

Use extreme caution when reversing or pulling the machine towards you. To avoid getting pinned against a structure, ensure adequate distance before reversing near a wall or fence. For machines with powered reverse drive capability, familiarize yourself with the operation of the Emergency Stop Control. It provides a means of stopping power to the tines and wheel drive in an emergency situation.

1. Locate the emergency stop control wire on the right side of the unit behind the engine.
2. Route the emergency stop control wire up and around the back of the right side handle bar and secure it just under the handlebar pivot, along with the clutch cables using a cable tie. See 1 in Figure 9.

**NOTE:** It will be easier to make adjustments to cable ties and wire positioning if left somewhat loose until all cable ties are positioned as desired.

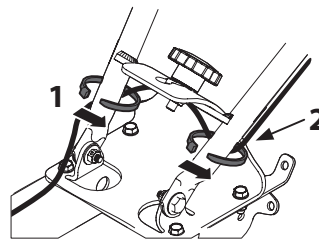

Figure 9

3. Secure the wire with a cable tie on the left side handlebar, just under the handlebar pivot, and route the wire up the left handlebar. See 2 in Figure 9.

**IMPORTANT:** It is necessary to leave enough slack in the wire when cable tying to the lower part of the handlebars to ensure a full range of motion when adjusting the handle height.

4. Secure the wire on the left handlebar with a cable tie just below the handle panel. See Figure 10.
5. Mount the emergency stop control ON/OFF switch onto the left handlebar with the #10-32 : 1.50 hex bolt and 10-32 flange lock nut. See 1 in Figure 11.
6. Secure the wire onto the left handlebar with a cable tie slightly above the handle panel. The wire must be routed along the outer side of the handlebar as shown, making sure that the wire does not interfere with movement of the drive control lever. See 2 in Figure 11.
7. Adjust all positioning of the wire and cable ties as needed before fully tightening the cable ties. Make sure there is a full range of height adjustment for the handlebar.

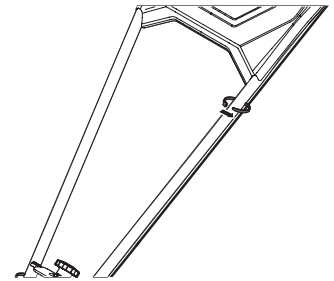

Figure 10

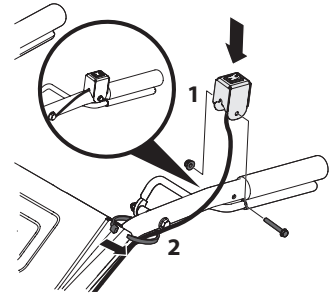

Figure 11

## Set-Up

### Tires

Use a tire pressure gauge to check the air pressure in both tires. Deflate or inflate both tires equally to between 15 PSI and 20 PSI.

**NOTE:** Be sure that both tires are inflated equally or the tiller will pull to one side.

### Gas & Oil Fill-Up

### ⚠ WARNING

Use extreme care when handling gasoline. Gasoline is extremely flammable and the vapors are explosive. Never fuel the machine indoors or while the engine is hot or running. Extinguish cigarettes, cigars, pipes and any other sources of ignition.

Service the engine with gasoline and oil as instructed in the Engine Operator's Manual packed separately with your tiller. Read the instructions carefully.

### Transmission Gear Oil

The transmission was filled with gear oil at the factory. However, be sure to check the oil level at this time to make certain it is correct. See the Service section for instructions on checking and adding transmission gear oil.

# CONTROLS & OPERATION

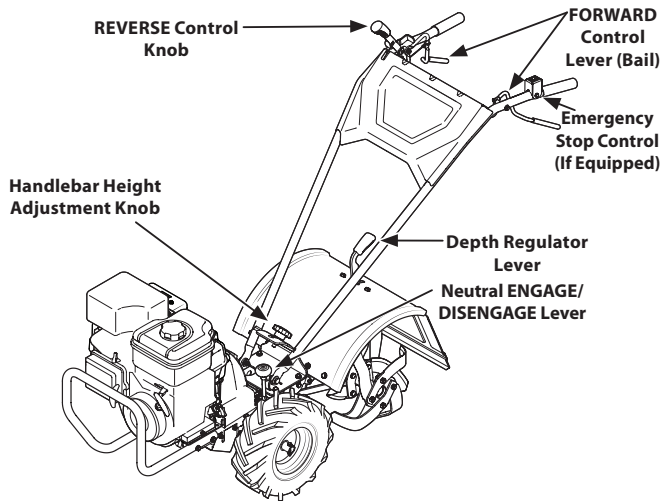

Figure 12

## Controls

**NOTE:** This Operator's Manual covers several garden tiller models. The tiller depicted may differ from yours.

**NOTE:** Refer to the separate Engine Operator's Manual for detailed information on all engine controls.

### Neutral ENGAGE/DISENGAGE Lever

This lever has two positions: ENGAGE and DISENGAGE.

### Forward Control Lever

The two interconnected levers control the engagement of forward drive to the wheels and tines (also known as the bail).

### Reverse Control Knob

The Reverse Control Lever controls the engagement of reverse drive to the wheels and tines.

### Depth Regulator Lever

The Depth Regulator lever controls the tilling depth of the tines.

### Handlebar Height Adjustment Knob

The Handlebar is adjustable to three different height settings.

### Emergency Stop Control (IF EQUIPPED)

The emergency stop control is a switch used to stop the tiller engine and tiller functions from the operator's position in emergency situations.

**NOTE:** Some engine models may also come equipped with an ignition ON/OFF switch. Consult the separate Engine Operator's Manual.

## Operation

### Engine Pre-Start Checklist

Disconnect the spark plug wire from the spark plug. Make the following checks and perform the following services before starting the engine.

1. Read the Safe Operation Practices and Assembly & Set-Up sections in this Operator's Manual.
2. Read the separate Engine Operator's Manual.
3. Check the machine for loose or missing hardware.
4. Check the engine oil level. See Engine Operator's Manual.
5. Check that all safety guards and covers are in place.
6. Check air cleaner and engine cooling system. See Engine Operator's Manual.
7. Attach the spark plug wire to the spark plug.
8. Fill the fuel tank with gasoline according to the directions in the separate Engine Operator's Manual. Follow all the instructions and safety rules carefully.

## ⚠ WARNING

To help prevent serious personal injury or damage to equipment, put both wheels in the WHEEL DRIVE position. Never have wheels in FREEWHEEL position when the engine is running. When the wheels are in FREEWHEEL, they do not hold back the tiller and the tines could propel the tiller rapidly forward or backward. Put the Forward Clutch Bail in neutral (disengaged) position by releasing the lever.

## ⚠ WARNING

Never run the engine indoors or in enclosed, poorly ventilated areas. Engine exhaust contains carbon monoxide, an odorless and deadly gas. Avoid the engine muffler and nearby areas. Temperatures in these areas may exceed 150° F.

### Starting the Engine

1. Complete the Pre-Start Checklist.
2. Put the NEUTRAL ENGAGE/DISENGAGE Lever in the ENGAGE position.
3. Move the Depth Regulator Lever all the way down to the "travel" position, so that the tines clear the ground. To change the depth setting, pull back on the Depth Regulator Lever (A) and lift up or down (B), then release the lever to secure it in the desired position. See Figure 13.
4. Release all controls on the tiller.
5. If equipped with an Emergency Stop Control switch, make sure that the Emergency Stop Control is set to the ON position, represented by the solid line, while attempting to start the engine. See Figure 14.

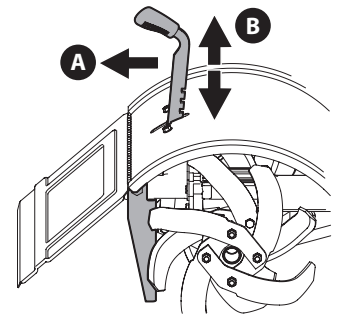

Figure 13

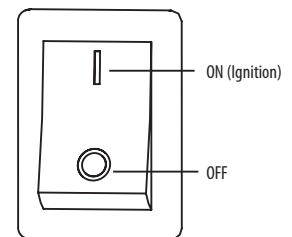

Figure 14

6. Put the Engine Throttle Control Lever in the FAST setting.
7. On engines equipped with a fuel valve, turn the valve to the open position as instructed in the separate Engine Operator's Manual.
8. Choke or prime engine as instructed in the separate Engine Operator's Manual.
9. For recoil (non-electric) starting models:
  - a. Place one hand on the fuel tank to stabilize the tiller when you pull the starter handle.
  - b. Use the recoil starter rope to start the engine as instructed in the separate Engine Operator's Manual. When the engine starts, gradually move the choke lever (on engines so equipped) to the NO CHOKE, CHOKE OFF or RUN position.
  - c. Leave the Engine Throttle Control Lever in the FAST setting.
10. For electric starting models refer to the Engine Operator's Manual for detailed starting instructions.

**NOTE:** Recoil starting works for electric start equipped units as well.

# CONTROLS & OPERATION

## Stopping the Engine

1. To stop the wheels and tines, release the Forward Control Levers or the Reverse Control Knob (whichever control may be engaged).
2. To stop the engine, move the Engine Throttle Control Lever to the "STOP" position.

**NOTE:** Electric start models may also be equipped with a STOP switch. Consult the separate Engine Operator's Manual for detailed starting and stopping instructions.

## Using Emergency Stop Control (IF EQUIPPED)

To stop the running engine using the Emergency Stop Control, move the switch to the OFF position, represented by the circle. See Figure 14.

## Engaging the Drive & Tines

1. For forward motion of the wheels and tines:
  - a. Pull the bail up and hold it against the handlebars. See Figure 15.

**NOTE:** When placing the NEUTRAL ENGAGE/DISENGAGE lever in the ENGAGE position, there may be a delay between pressing the bail and the transmission beginning to drive. This is normal. Though pressing the bail should cause the lever to ENGAGE the unit in drive, to quickly and accurately ENGAGE the transmission into drive gently rock the tiller backward and forward on the wheels. The transmission will click into drive and you will be able to feel the proper drive resistance from the wheels.

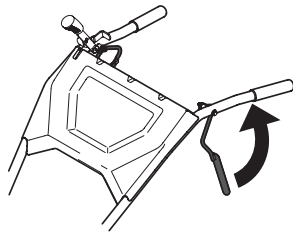

Figure 15

- b. As the tiller drives forward the tines will also rotate, digging into the ground. Walk behind and a little to one side of the tiller. Use a secure, comfortable grip on the handlebars. Let the tiller move ahead at its own pace. See Figure 16. To stop the forward motion of the wheels and tines, release the bail.

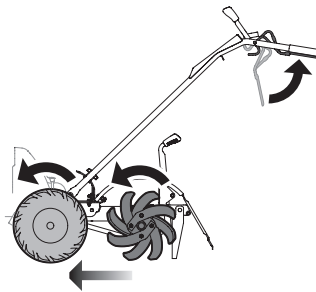

Figure 16

## ⚠ WARNING

Do not push down on the handlebars to try to make the tiller till more deeply. This prevents the wheels from holding the tiller back and can allow the tines to rapidly propel the tiller forward, which could result in loss of control, property damage or personal injury.

2. For reverse motion of the wheels and tines:
  - a. Stop all forward motion before reversing.
  - b. Lift the handlebars until the tines are slightly off the ground and then pull the Reverse Control Knob out to engage the reverse motion. See Figure 17.
  - c. While driving in reverse the tines will also rotate in reverse. See Figure 18.

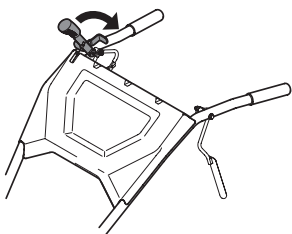

Figure 17

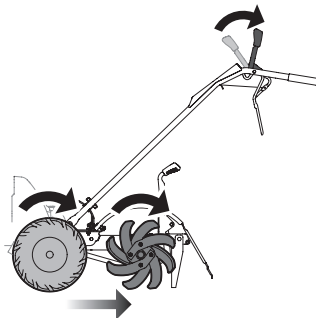

Figure 18

## ⚠ WARNING

Look behind and exercise caution while operating in reverse. Do not attempt to till when in reverse.

- d. To stop the reverse motion, let go of the Reverse Drive Control Knob.

## Turning the Tiller

1. Practice turning the tiller in a level, open area. Be very careful to keep your feet and legs away from the tines.
2. To make a turn, reduce the drive speed and lift the handlebars slightly until the tines are balanced just above the ground.
3. With the tiller balanced, push the handlebars to one side to turn. After completing the turn, slowly lower the tines into the soil and increase the drive speed.

## Clearing the Tines

The tines have a self-clearing feature that cuts down tangling of debris in the tines. However, debris may occasionally become entangled. Follow these procedures to help avoid tangling and to clean the tines, if necessary:

- To reduce tangling, set the depth regulator deep enough to get maximum "chopping" action as the tines chop the material against the ground.
- Try to till under crop residues or cover crops while they are green, moist and tender.
- While power composting, try swaying the handlebars from side to side in a controlled manner (about 6" to 12"). This "fishtailing" action often clears the tines of debris.
- If tangling occurs, lift the tines out of the soil and run the tiller in reverse for a few feet. This reversing action should unwind a good deal of debris.
- If reversing the tiller doesn't clear the debris, it may be necessary to remove the debris by hand.

## ⚠ WARNING

Before clearing the tines by hand, stop the engine, allow all moving parts to stop and disconnect the spark plug wire. Failure to follow this warning could result in personal injury.

## Tilling Tips & Techniques

## ⚠ WARNING

Before tilling, contact your telephone or utilities company and inquire if underground equipment or lines are used on your property. Do not till near buried electric cables, telephone lines, pipes or hoses.

## Let the Tiller Do the Work

- While tilling, relax and let the wheels pull the tiller along while the tines do the digging. Walk on the side that is not yet finished to avoid making footprints in the freshly tilled soil. Lightly, but securely, grip the handlebar with just one hand.
- Avoid pushing down on the handlebars in an attempt to force the tiller to dig deeper. Doing so takes the weight off the powered wheels, causing them to lose traction. Without the wheels helping to hold the tiller back, the tines will attempt to propel the tiller — often causing the tiller to skip rapidly across the ground.
- Sometimes, slight downward pressure on the handlebars will help get through a particularly tough section of sod or unbroken ground, but in most cases this won't be necessary at all.

# CONTROLS & OPERATION

## Tilling Depths

- Avoid trying to dig too deeply too quickly, especially when busting sod or when tilling soil that hasn't been tilled for some time. Use the shallow depth regulator settings — only an inch or two deep — for the first passes through the garden area. With each succeeding pass, adjust the depth regulator to dig an inch or two deeper. Watering the garden area a few days prior to tilling will make tilling easier, as will letting the newly worked soil set for a day or two before making a final, deep tilling pass.
- When cultivating, use very shallow depth settings to prevent injury to plants whose roots often grow close to the surface. If needed, lift up on the handlebars slightly to prevent the tines from digging too deeply. Cultivating on a regular basis not only eliminates weeds, it also loosens and aerates the soil for better moisture absorption and faster plant growth. See Figure 19.

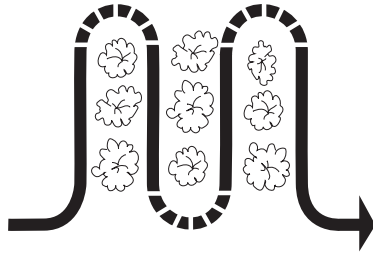

Figure 19

## Avoid Tilling Soggy, Wet Soil

- Tilling wet soil often results in large, hard clumps of soil that can interfere with planting. If time permits, wait a day or two after heavy rains to allow the soil to dry before tilling. Test soil by squeezing it into a ball. If it compresses too easily, it is too wet to till.

## Avoid Making Footprints

- When possible, walk on the untilled side of the machine to avoid making footprints in the freshly tilled soil. Footprints cause soil to compact, which can hamper root penetration and contribute to soil erosion. They can also “plant” unwanted weed seeds back into the freshly tilled ground.

## Choosing Correct Wheel and Tine Speeds

With experience, you will find the tilling depth and tilling speed combination that is best for your garden.

- Set the Engine Throttle Control Lever to a speed that will give the engine adequate power and still allow it to operate at the slowest possible speed until you have achieved your desired tilling depth.
- Selection of the correct engine speed, in relation to the tilling depth, will ensure a sufficient power level to do the job without causing the engine to labor.
- Faster engine speeds may be desirable when making final passes through the seedbed or when cultivating.

## Power Composting

Power composting simply means tilling through all manner of organic matter, such as crop residues, leaves, grass clippings and cover crops, burying them in the soil. This material will decompose during the non-growing season and add important natural nutrients to the soil. It is best to follow the below guidelines when power composting.

### WARNING

When power composting, do not keep the depth regulator lever at a deep setting if the tiller jumps or bucks. If jumping or bucking occurs, move the depth regulator lever down to one of the shallower settings and then slowly increase the tilling depth on later passes. Failure to follow this warning could result in personal injury.

- The first place to begin is with crop residues such as leftover vines, stalks, stems and roots. Power compost these crop residues as soon as they finish bearing. The sooner this is done, the better, as tender green matter is easier to till into the soil. Use the deepest depth regulator setting possible without causing the engine to labor or the tiller to jump ahead.

- Standing cornstalks of reasonable height can be power composted. Pushing over, but not uprooting, cornstalks will often make it easier for your tiller to chop up the stalks. Keep the tines clear of excessive tangling by “fishtailing” or frequently using reverse. Make several passes, then return a few days later to finish off any straggling standers.
- After tilling under crop residues, add more organic matter such as leaves, grass clippings and even kitchen scraps. When tilled into the soil, this organic matter will decompose and add even more important nutrients to the soil.
- After power composting, you may want to plant a “green manure” cover crop to protect the soil during the off-season. You simply grow a crop of clover, alfalfa, buckwheat, peas, beans, rye grass, grain or kale and then till it into the soil prior to the planting season.

## Loading & Unloading the Tiller

### WARNING

Loading and unloading the tiller into a vehicle is potentially hazardous and doing so is not recommended unless absolutely necessary, as this could result in personal injury or property damage. However, if you must load or unload the tiller, follow the below guidelines.

- Before loading or unloading, stop the engine, wait for all parts to stop moving, disconnect the spark plug wire and let the engine and muffler cool. Remove the ignition key on electric start models.
- The tiller is too heavy (over 170 lbs., depending on model) for one person to lift safely. Two or more people should share the load.
- Use sturdy ramps and, with the engine shut off, manually roll the tiller into and out of the vehicle. Two or more people are needed to do this.
- Ramps must be strong enough to support the combined weight of the tiller and any handlers. The ramps should provide good traction to prevent slipping, they should have side rails to guide the tiller along the ramps and they should have a locking device to secure them to the vehicle.
- The handlers should wear sturdy footwear that will help to prevent slipping.
- Position the loading vehicle so that the ramp angle is as flat as possible. The less incline to the ramp, the better. Turn the vehicle's engine off and apply its parking brake.
- When going up ramps, stand in the normal operating position and push the tiller ahead of you. Have a person at each side to turn the wheels.
- When going down ramps, walk backward with the tiller following you. Keep alert for any obstacles behind you. Position a person at each wheel to control the speed of the tiller. Never go down the ramps tiller-first, as the tiller could tip forward.
- Use wooden blocks to place on the downhill side of the wheels if you need to stop the tiller from rolling down the ramp. Also, use the blocks to temporarily keep the tiller in place on the ramps (if necessary), and to chock the wheels in place after the tiller is in the vehicle.
- When the tiller is in the vehicle, prevent it from rolling by engaging the wheels in the WHEEL DRIVE position. Chock the wheels with blocks and securely tie the tiller down.

# SERVICE

## ⚠ WARNING

Before inspecting, cleaning or servicing the machine, shut off the engine, wait for all moving parts to come to a complete stop, wait for the engine to cool, disconnect the spark plug wire and move the wire away from the spark plug. Failure to follow these instructions can result in serious personal injury or property damage.

## Maintenance

### Engine

Refer to the Engine Operator's Manual packed with your tiller for all engine maintenance.

### Tire Pressure

Check the air pressure in both tires. The proper air pressure is printed on the side of the tires. Keep both tires equally inflated to help prevent the machine from pulling to one side.

### Lubrication

After every 10 operating hours, oil or grease the lubrication points shown in Figure 20.

Use a clean lubricating oil (#30 weight motor oil is suitable) and a clean general purpose grease (grease containing a metal lubricant is preferred).

- Remove the wheels, clean the wheel shaft and apply a thin coating of grease to the wheel shaft.
- Grease the back, front and sides of the depth regulator lever.
- Remove the tines and clean the tine shaft. Use a file or sandpaper to gently remove any rust, burrs or rough spots (especially around holes in the shaft). Apply grease to the ends of the shaft before installing the tines.
- Oil the threads on the handlebar height adjustment screws and the handlebar attaching screws.

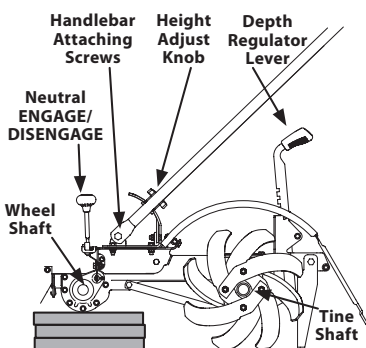

Figure 20

### Hardware

Check for loose or missing hardware after every 10 operating hours and tighten or replace (as needed) before using tiller.

Be sure to check the screws underneath the tiller hood that secure the transmission cover and the Depth Regulator Lever to the transmission.

## Transmission Gear Oil

### Checking the Transmission Gear Oil

Check the transmission gear oil after every 30 hours of operation or whenever you notice any oil leaks. Operating the tiller when the transmission is low on oil can result in severe damage.

1. Check the gear oil level when the transmission is cool. Gear oil will expand in warm operating temperatures and this expansion will provide an incorrect oil level reading.
2. With the tiller on level ground, pull the Depth Regulator Lever all the way up.

3. Remove the hex washer screw (1/4-20 x .500) and flat washer (.28 x .74 x .063) from the left side of the belt cover and the hex washer screw (1/4-20 x .500) from the right side of the belt cover. Remove the belt cover. See Figure 21.

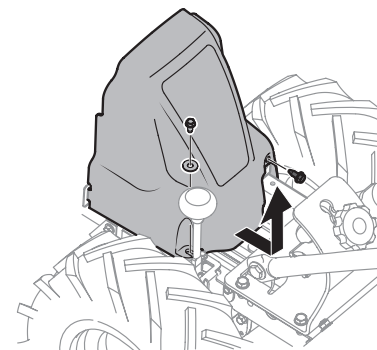

Figure 21

4. Thoroughly clean the area around the transmission cover.
5. Remove the four hex screws (5/16-18 x .75) securing the transmission cover to the drive shaft and remove the cover. Locate the main drive shaft below the cover. See Figure 22.
6. The gear oil level is correct if the gear oil is approximately halfway up the side of the main drive shaft.
7. If the gear oil level is low, add gear oil immediately. If the gear oil level is okay, securely reinstall the transmission cover and reinstall the belt cover.

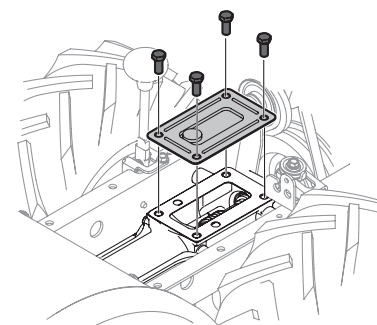

Figure 22

- NOTE:** When reinstalling the belt cover, be sure to engage the bail and hold it so that the drive belt is tight before attempting to reinstall the belt cover. This will enable the belt to fall under the belt keeping mechanism built into the belt cover. Failure to do so could damage the belt and/or belt cover.
8. When adding gear oil, use synthetic 75W 140. You may add gear oil with the transmission cover off, or reinstall the transmission cover and pour through the oil fill hole, located on top of the transmission cover, and secured with a plug.
  9. While checking frequently to avoid overfilling, slowly add gear oil into the oil fill hole until it reaches the halfway point on the drive shaft.

### Changing the Transmission Gear Oil

**NOTE:** Transmission gear oil does not need to be changed unless it has been contaminated with dirt or sand particles.

1. Drain the gasoline from the fuel tank or run the engine until the fuel tank is empty.
2. Drain the oil from the engine.
3. Remove the belt cover and clean and remove the transmission cover as in Steps 3-5 in Checking the Transmission Gear Oil.
4. Remove the left-side wheel by removing the nut and bolt from the wheel axle. See Figure 23.
5. Tilt the left-side wheel shaft into a drain pan and allow the gear oil to drain out through the top of the transmission.

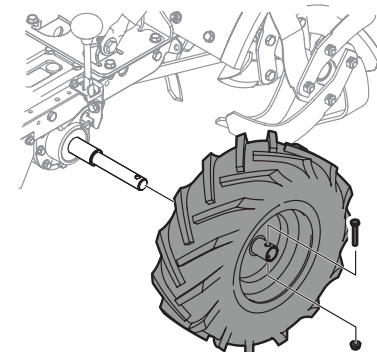

Figure 23

# SERVICE

6. Reinstall the wheel and reinstall the transmission cover.
7. Refill the transmission using synthetic 75W 140. Refill the engine with motor oil and replenish the fuel tank with gasoline.
8. Reinstall the belt cover.

## Off-Season Storage

When the tiller won't be used for an extended period, prepare it for storage as follows:

1. Clean the tiller and engine.
2. Do routine tiller lubrication and check for loose parts and hardware.
3. Protect the engine and perform recommended engine maintenance by following the storage instructions found in the Engine Operator's Manual. Be sure to protect the fuel lines, carburetor and fuel tank from gum deposits by removing fuel or by treating fuel with a fuel stabilizer (follow the engine manufacturer's recommendations).
4. Store the tiller in a clean, dry area.
5. Never store the tiller with fuel in the fuel tank in an enclosed area where gas fumes could reach an open flame or spark, or where ignition sources are present (space heaters, hot water heaters, furnaces, etc.).

## Tines

### Replacing Individual Tines

1. Remove the two nuts that attach a single tine to the screws on the tine assembly. If needed, use penetrating oil to help free the nuts. See Figure 24.
2. When installing a single tine, be sure to position it so that its cutting edge will enter the soil first as the tiller moves forward.

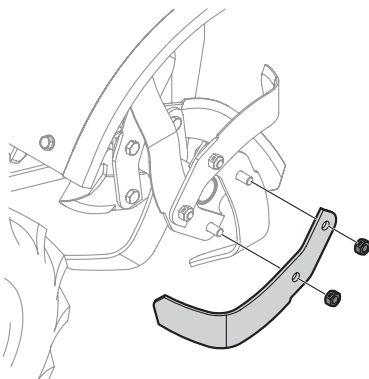

Figure 24

### Removing a Tine Assembly

1. If removing both tine assemblies, mark them "left" and "right" before removal. Doing so will help ensure that the assemblies are reinstalled on the correct sides of the tiller.
2. While not necessary, removing all tines from around the outside of the tine assembly will make accessing the tine assembly hardware easier. See A in Figure 25.
3. Remove the screw and lock nut that secure the tine assembly to the tine shaft. See B in Figure 25. These pieces of hardware run through the center of the tine assembly and the shaft. Pull the tine assembly off the shaft. If necessary, use a rubber mallet to tap the tine assembly outward.
4. Before reinstalling the tine assembly, inspect the tine shaft for rust, rough spots or burrs and file or sand as needed. Then apply a thin coat of grease to the shaft.
5. Install each tine assembly so that the cutting edge of the tines will enter the soil first when the tiller moves forward. Secure the tine assembly to the tine shaft using the screw and lock nut previously removed. Tighten securely.

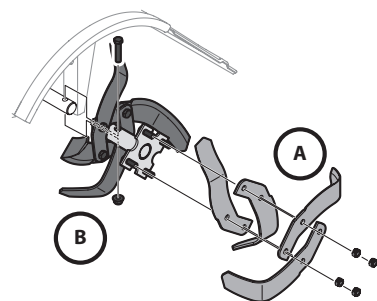



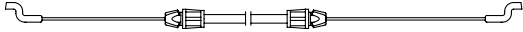
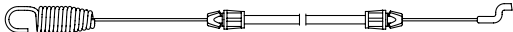





Figure 25

# TROUBLESHOOTING

Problem	Cause	Remedy
<b>Wheels/tines will not turn</b>	<ol style="list-style-type: none"> <li>1. Improper use of controls.</li> <li>2. Worn or broken clutch belt.</li> <li>3. Internal transmission wear or damage.</li> <li>4. Bolt and key loose in transmission pulley.</li> </ol>	<ol style="list-style-type: none"> <li>1. Review Controls &amp; Operation section.</li> <li>2. Contact authorized service dealer.</li> <li>3. Contact authorized service dealer.</li> <li>4. Contact authorized service dealer.</li> </ol>
<b>Tines turn, but wheels don't</b>	<ol style="list-style-type: none"> <li>1. Wheel mounting hardware missing.</li> <li>2. Bolt and key loose in transmission pulley.</li> <li>3. Internal transmission wear or damage.</li> <li>4. Wheel Gear Lever not fully ENGAGED.</li> </ol>	<ol style="list-style-type: none"> <li>1. Replace hardware.</li> <li>2. Tighten bolt; check that key is in place.</li> <li>3. Contact authorized service dealer.</li> <li>4. Ensure lever is ENGAGED and gently rock tiller back and forth.</li> </ol>
<b>Wheels turn, but tines don't</b>	<ol style="list-style-type: none"> <li>1. Tine holder mounting hardware missing.</li> <li>2. Internal transmission wear or damage.</li> </ol>	<ol style="list-style-type: none"> <li>1. Replace hardware.</li> <li>2. Contact authorized service dealer.</li> </ol>
<b>Poor tilling performance</b>	<ol style="list-style-type: none"> <li>1. Worn tines.</li> <li>2. Improper Depth Regulator setting.</li> <li>3. Incorrect throttle setting.</li> <li>4. Belt(s) slipping.</li> </ol>	<ol style="list-style-type: none"> <li>1. See Service section.</li> <li>2. See Controls &amp; Operation section.</li> <li>3. See Controls &amp; Operation section.</li> <li>4. Contact an authorized service dealer.</li> </ol>

# REPLACEMENT PARTS

Problem	Cause	
	754-04091	Reverse Drive Belt, 3L x 29.125
	754-04090	Forward Drive Belt, 4L x 25.375
	742-04223 742-04224	Bolo Tine (LH), 12" Bolo Tine (RH), 12"
	634-04232	Wheel, 13 x 5 x 6
	746-04414A	Reverse Cable
	746-04413A	Forward Cable
	710-05289	Screw, 1/4-20 : 1.5 (Wheel Mount)
	712-04064	Flange Lock Nut, 1/4-20 (Wheel Mount)
	710-0347	Hex Screw, 3/8-16 : 1.75 (Tine Assembly)
	712-04065	Flange Lock Nut, 3/8-16 (Tine Assembly)

Phone (800) 828-5500 to order replacement parts or a complete Parts Manual (have your full model number and serial number ready). Parts Manual downloads are also available at [www.troybilt.com](http://www.troybilt.com).

## NOTES

## NOTES

# MANUFACTURER'S LIMITED WARRANTY FOR



The limited warranty set forth below is given by Troy-Bilt LLC with respect to new merchandise purchased and used in the United States and/or its territories and possessions, and by MTD Products Limited with respect to new merchandise purchased and used in Canada and/or its territories and possessions (either entity respectively, "Troy-Bilt").

This warranty is in addition to any applicable emissions warranty provided with your product.

"Troy-Bilt" warrants this product (excluding its *Belts*, *Transmission* and *Attachments* as described below) against defects in material and workmanship for a period of two (2) years commencing on the date of original purchase and will, at its option, repair or replace, free of charge, any part found to be defective in materials or workmanship. This limited warranty shall only apply if this product has been operated and maintained in accordance with the Operator's Manual furnished with the product, and has not been subject to misuse, abuse, commercial use, neglect, accident, improper maintenance, alteration, vandalism, theft, fire, water, or damage because of other peril or natural disaster. Damage resulting from the installation or use of any part, accessory or attachment not approved by Troy-Bilt for use with the product(s) covered by this manual will void your warranty as to any resulting damage.

*Belts* are warranted to be free from defects in material and workmanship for a period of thirty (30) days from the date of purchase.

*Transmission* — Troy-Bilt warrants the transmission (including all gears, shafts and housings) against defects in material and workmanship for the life of the tiller, to the original purchaser only, commencing on the date of original purchase or lease.

*Attachments* — Troy-Bilt warrants attachments for this product against defects in material and workmanship for a period of one (1) year, commencing on the date of the attachment's original purchase or lease. Attachments include, but are not limited to items such as: grass collectors and mulch kits.

**HOW TO OBTAIN SERVICE:** Warranty service is available, WITH PROOF OF PURCHASE, through your local authorized service dealer. To locate the dealer in your area:

## In the U.S.A.

Check your Yellow Pages, or contact Troy-Bilt LLC at P.O. Box 361131, Cleveland, Ohio 44136-0019, or call 1-866-840-6483, 1-330-558-7220 or log on to our Web site at [www.troybilt.com](http://www.troybilt.com).

## In Canada

Contact MTD Products Limited, Kitchener, ON N2G 4J1, or call 1-800-668-1238 or log on to our Web site at [www.mtdcanada.com](http://www.mtdcanada.com).

This limited warranty does **not** provide coverage in the following cases:

- a. The engine or component parts thereof. These items may carry a separate manufacturer's warranty. Refer to applicable manufacturer's warranty for terms and conditions.

- b. Log splitter pumps, valves, and cylinders have a separate one-year warranty.
- c. Routine maintenance items such as lubricants, filters, blade sharpening, tune-ups, brake adjustments, clutch adjustments, deck adjustments, and normal deterioration of the exterior finish due to use or exposure.
- d. Service completed by someone other than an authorized service dealer.
- e. Troy-Bilt does not extend any warranty for products sold or exported outside of the United States and/or Canada, and their respective possessions and territories, except those sold through Troy-Bilt's authorized channels of export distribution.
- f. Replacement parts that are not genuine Troy-Bilt parts.
- g. Transportation charges and service calls.
- h. Troy-Bilt does not warrant this product for commercial use.

**No implied warranty, including any implied warranty of merchantability or fitness for a particular purpose, applies after the applicable period of express written warranty above as to the parts as identified. No other express warranty, whether written or oral, except as mentioned above, given by any person or entity, including a dealer or retailer, with respect to any product, shall bind Troy-Bilt. During the period of the warranty, the exclusive remedy is repair or replacement of the product as set forth above.**

**The provisions as set forth in this warranty provide the sole and exclusive remedy arising from the sale. Troy-Bilt shall not be liable for incidental or consequential loss or damage including, without limitation, expenses incurred for substitute or replacement lawn care services or for rental expenses to temporarily replace a warranted product.**

Some states do not allow the exclusion or limitation of incidental or consequential damages, or limitations on how long an implied warranty lasts, so the above exclusions or limitations may not apply to you.

In no event shall recovery of any kind be greater than the amount of the purchase price of the product sold. **Alteration of safety features of the product shall void this warranty.** You assume the risk and liability for loss, damage, or injury to you and your property and/or to others and their property arising out of the misuse or inability to use the product.

This limited warranty shall not extend to anyone other than the original purchaser or to the person for whom it was purchased as a gift.

**HOW STATE LAW RELATES TO THIS WARRANTY:** This limited warranty gives you specific legal rights, and you may also have other rights which vary from state to state.

**IMPORTANT:** Owner must present Original Proof of Purchase to obtain warranty coverage.

**Troy-Bilt LLC, P.O. BOX 361131 CLEVELAND, OHIO 44136-0019; Phone: 1-866-840-6483, 1-330-558-7220  
MTD Canada Limited - KITCHENER, ON N2G 4J1; Phone 1-800-668-1238**