

Cub Cadet

OPERATOR'S MANUAL

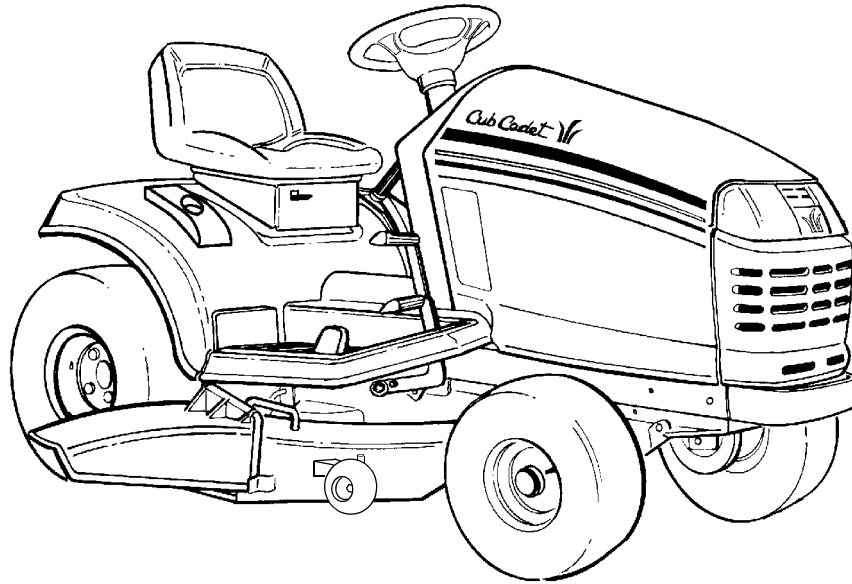

SERIES 2000

TRACTOR

Model Number

GT 2186-44

w/44" Mower Deck

IMPORTANT: READ SAFETY RULES AND INSTRUCTIONS CAREFULLY

Warning: This unit is equipped with an internal combustion engine and should not be used on or near any unimproved forest-covered, brush-covered or grass-covered land unless the engine's exhaust system is equipped with a spark arrester meeting applicable local or state laws (if any). If a spark arrester is used, it should be maintained in effective working order by the operator. In the State of California the above is required by law (Section 4442 of the California Public Resources Code). Other states may have similar laws. Federal laws apply on federal lands. A spark arrester for the muffler is available through your nearest engine authorized service dealer or contact the service department, P.O. Box 361131 Cleveland, Ohio 44136-0019.

CUB CADET LLC P.O. BOX 361131 CLEVELAND, OHIO 44136-0019 [www.cubcadet.com]

KOHLER CO.
FEDERAL AND CALIFORNIA EMISSION CONTROL SYSTEMS
LIMITED WARRANTY
SMALL OFF-ROAD EQUIPMENT ENGINES

The U.S. Environmental Protection Agency (EPA), the California Air Resources Board (CARB), and Kohler Co. are pleased to explain the Federal and California Emission Control Systems Warranty on your small off-road equipment engine (herein engine). For California, engines produced in 1995 and later must be designed, built and equipped to meet the state's stringent anti-smog standards. In other states, 1997 and later model year engines must be designed, built and equipped, to meet the U.S. EPA regulations for small non-road engines. The engine must be free from defects in materials and workmanship which cause it to fail to conform with U.S. EPA standards for the first two years of engine use from the date of sale to the ultimate purchaser. Kohler Co. must warrant the emission control system on the engine for the period of time listed above, provided there has been no abuse, neglect or improper maintenance.

The emission control system may include parts such as the carburetor or fuel injection system, the ignition system, and catalytic converter. Also included are the hoses, belts and connectors and other emission related assemblies.

Where a warrantable condition exists, Kohler Co. will repair the engine at no cost, including diagnosis (if the diagnostic work is performed at an authorized dealer), parts and labor.

MANUFACTURER'S WARRANTY COVERAGE

Engines produced in 1995 or later are warranted for two years in California. In other states, 1997 and later model year engines are warranted for two years. If any emission related part on the engine is defective, the part will be repaired or replaced by Kohler Co. free of charge.

OWNER'S WARRANTY RESPONSIBILITIES

- (a) The engine owner is responsible for the performance of the required maintenance listed in the owner's manual. Kohler Co. recommends that you retain all receipts covering maintenance on the engine. But Kohler Co. cannot deny warranty solely for the lack of receipts or for your failure to assure that all scheduled maintenance was performed.
- (b) Be aware, however, that Kohler Co. may deny warranty coverage if the engine or a part has failed due to abuse, neglect, improper maintenance or unapproved modifications.
- (c) For warranty repairs, the engine must be presented to a Kohler Co. service center as soon as a problem exists. Call 1-800-544-2444, or access our web site at: www.kohlerengines.com, for the names of the nearest service centers. The warranty repairs should be completed in a reasonable amount of time, not to exceed 30 days.

If you have any questions regarding warranty rights and responsibilities, you should contact Kohler Co. at 1-920-457-4441 and ask for an Engine Service representative.

COVERAGE

Kohler Co. warrants to the ultimate purchaser and each subsequent purchaser that the engine will be designed, built and equipped, at the time of sale, to meet all applicable regulations. Kohler Co. also warrants to the initial purchaser and each subsequent purchaser, that the engine is free from defects in material and workmanship which cause the engine to fail to conform with applicable regulations for a period of two years.

Engines produced in 1995 or later are warranted for two years in California. For 1997 and later model years, EPA requires manufacturers to warrant engines for two years in all other states. These warranty periods will begin on the date the engine is purchased by the initial purchaser. If any emission related part on the engine is defective, the part will be replaced by Kohler Co. at no cost to the owner. Kohler Co. is liable for damages to other engine components caused by the failure of a warranted part still under warranty.

Kohler Co. shall remedy warranty defects at any authorized Kohler Co. engine dealer or warranty station. Warranty repair work done at an authorized dealer or warranty station shall be free of charge to the owner if such work determines that a warranted part is defective.

Listed below are the parts covered by the Federal and California Emission Control Systems Warranty. Some parts listed below may require scheduled maintenance and are warranted up to the first scheduled replacement point for that part. The warranted parts are:

- Oxygen sensor (if equipped)
- Intake manifold (if equipped)
- Exhaust manifold (if equipped)
- Catalytic muffler (if equipped)
- Fuel metering valve (if equipped)
- Spark advance module (if equipped)
- Crankcase breather
- Ignition module(s) with high tension lead
- Gaseous fuel regulator (if equipped)
- Electronic control unit (if equipped)
- Carburetor or fuel injection system
- Fuel lines (if equipped)
- Air filter, fuel filter, and spark plugs (only to first scheduled replacement point)

LIMITATIONS

This Emission Control System Warranty shall not cover any of the following:

- (a) repair or replacement required because of misuse or neglect, improper maintenance, repairs improperly performed or replacement not conforming to Kohler Co. specifications that adversely affect performance and/or durability and alterations or modifications not recommended or approved in writing by Kohler Co.,
- (b) replacement of parts and other services and adjustments necessary for required maintenance at and after the first scheduled replacement point,
- (c) consequential damages such as loss of time, inconvenience, loss of use of the engine or equipment, etc.,
- (d) diagnosis and inspection fees that do not result in eligible warranty service being performed, and
- (e) any add-on or modified part, or malfunction of authorized parts due to the use of add-on or modified parts.

MAINTENANCE AND REPAIRS REQUIREMENTS

The owner is responsible for the proper use and maintenance of the engine. Kohler Co. recommends that all receipts and records covering the performance of regular maintenance be retained in case questions arise. If the engine is resold during the warranty period, the maintenance records should be transferred to each subsequent owner. Kohler Co. reserves the right to deny warranty coverage if the engine has not been properly maintained; however, Kohler Co. may not deny warranty repairs solely because of the lack of repair maintenance or failure to keep maintenance records.

Normal maintenance, replacement or repair of emission control devices and systems may be performed by any repair establishment or individual; however, **warranty repair must be performed by a Kohler authorized service center**. Any replacement part or service that is equivalent in performance and durability may be used in non-warranty maintenance or repairs, and shall not reduce the warranty obligations of the engine manufacturer.

CONTENTS

Section	Page	Section	Page
Emission Control Systems Warranty ...	2	VI Off-Season Storage	45
Tractor and Deck Preparation.....	3	VII Mowing.....	46
Safe Operation Practices	4	Optional Equipment and Accessories .	47
Product Graphics	7	Maintenance Chart.....	48
To The Owner	8	Trouble Shooting.....	49
Calling Service Information.....	8	Lubrication Table	51
Recording Model & Serial Number	8	Lubrication Guides	52
I Controls and Indicators.....	9	Slope Gauge	55
II Operation	14	Specifications.....	57
III Adjustments	18	Warranty — Commercial Use	58
IV Maintenance	23	Warranty — Residential Use.....	59
V Mower Deck.....	33	Maintenance Parts Chart	60

TRACTOR AND DECK PREPARATION

A. ATTACHING THE CHUTE DEFLECTOR



WARNING

Do not operate the mower deck without the chute deflector installed and in its down position.

1. Remove the hex cap screws, bell washers and hex nuts installed in the deck at the chute opening.
2. Position the hinge bracket of the deflector assembly to align with the holes in deck. Insert the hex cap screws from the underside of the deck and secure with the bell washers and hex nuts. Note: the crowned (rounded) surface of the washers go toward the hex nuts.

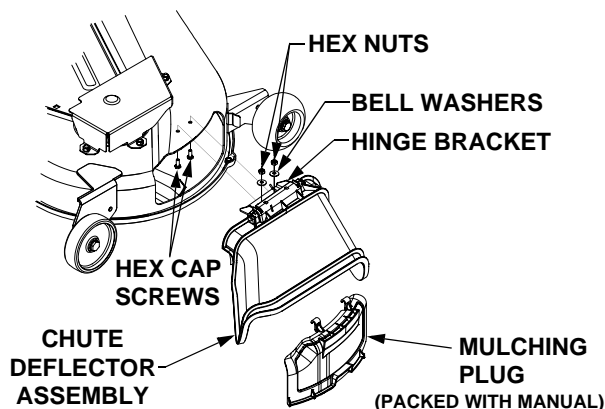

3. Refer to **SECTION V-MOWER DECK** when installing the mulching plug.

B. LIFT ASSIST SPRING

The RH lift assist spring may have been received in the manual bag, or may have been installed at the factory.

If the spring is NOT installed, the RH lift assist **rod** on the tractor is secured to the pigtail hook with a rubber band for shipment. From beneath the right rear fender, remove the rubber band from the rod and pigtail hook.

If the lift assist spring is not installed, refer to **INSTALLING LIFT ASSIST SPRING** in **SECTION V** (page 33) for installation instructions.

C. CONNECT THE BATTERY



WARNING

Battery posts, terminals and related accessories contain lead and lead compounds. **Wash hands after handling.**

The tractor is shipped with an activated sealed battery, with the positive battery cable factory connected. The negative cable must be connected.

Note: Make sure the ignition switch is in the "OFF" position before attaching the battery cables.

1. Pull the protective cap off the negative terminal of the battery, and remove the hex cap screw and nut from the free end of the negative battery cable.
2. Connect the negative battery cable (heavy black) and ground wire (green) to negative terminal (—) of the battery using the hex cap screw and nut.
3. Slide the black terminal cover over the negative terminal of the battery.



WARNING

- The engine exhaust, some of its constituents, and certain vehicle components contain or emit chemicals known to the State of California to cause cancer, birth defects or other reproductive harm.
- This unit is equipped with an internal combustion engine and should not be used on or near any unimproved forest-covered, brush-covered, or grass-covered land unless the engine's exhaust system is equipped with a spark arrester meeting applicable local or state laws (if any). If a spark arrester is used, it should be maintained in effective working order by the operator.
- In the State of California, the above is required by law (Section 4442 of the California Public Resources Code). Other States may have similar laws. Federal laws apply to federal lands. A spark arrester muffler is available at your nearest engine authorized service center.

IMPORTANT

SAFE OPERATION PRACTICES



THIS SYMBOL POINTS OUT IMPORTANT SAFETY INSTRUCTIONS WHICH, IF NOT FOLLOWED, COULD ENDANGER THE PERSONAL SAFETY AND/OR PROPERTY OF YOURSELF AND OTHERS. READ AND FOLLOW ALL INSTRUCTIONS IN THIS MANUAL BEFORE ATTEMPTING TO OPERATE YOUR UNIT. FAILURE TO COMPLY WITH THESE INSTRUCTIONS MAY RESULT IN PERSONAL INJURY. WHEN YOU SEE THIS SYMBOL—  **HEED ITS WARNING.**



DANGER

Your lawn mower was built to be operated according to the rules for safe operation in this manual. As with any type of power equipment, carelessness or error on the part of the operator can result in injury. This lawn mower is capable of amputating hands and feet or throwing objects. Failure to observe the following safety instructions could result in serious injury or death.



I. GENERAL OPERATION

1. Read, understand and follow all instructions in the manual and on the machine before starting. Keep this manual in a safe place for future and regular reference.
2. Only allow responsible individuals familiar with the instructions to operate the machine. Know the controls and how to stop the machine quickly.
3. Do not put hands or feet under the cutting deck or near rotating parts.
4. Clear the area of objects such as rocks, toys, wire, etc. which could be picked up and thrown by the blades. A small object may have been overlooked and could be accidentally thrown by the mower in any direction and cause injury to you or a bystander. To help avoid a thrown objects injury, keep children, animals, bystanders and helpers at least 75 feet from the mower while it is in operation. Always wear safety glasses with side shields or safety goggles during operation or while performing an adjustment or repair, to protect eyes from foreign objects. Stop the blades when crossing gravel drives, walks or roads.
5. Be sure the area is clear of other people before mowing. Stop machine if anyone enters the area.
6. Never carry passengers.
7. Disengage the blades before shifting into reverse and backing up. Always look down and behind before and while backing.
8. Be aware of the mower and attachment discharge direction and do not point it at anyone. Do not operate the mower without either the entire grass catcher or the chute guard in place.
9. Slow down before turning. Operate the machine smoothly. Avoid erratic operation and excessive speed.
10. Never leave a running machine unattended. Always turn off the blades, place the transmission in neutral, set the parking brake, stop the engine and remove key before dismounting.
11. Turn off blades when not mowing.
12. Stop the engine and wait until the blades come to a complete stop before (a) removing the grass catcher or unclogging chute, or (b) making any repairs, adjusting or removing any grass or debris.

13. Mow only in daylight or good artificial light.
14. Do not operate the machine while under the influence of alcohol or drugs.
15. Watch for traffic when operating near or crossing roadways.
16. Use extra care when loading or unloading the machine into a trailer or truck. This unit should not be driven up or down a ramp onto a trailer or truck under power because the unit could tip over, causing serious personal injury. The unit must be pushed manually on a ramp to load or unload properly.
17. Never make a cutting height adjustment while the engine is running if the operator must dismount to do so.
18. Wear sturdy, rough-soled work shoes and close-fitting slacks and shirts. Do not wear loose fitting clothes or jewelry. They can be caught in moving parts. Never operate a unit in bare feet, sandals or sneakers.
19. Check overhead clearance carefully before driving under power lines, wires, bridges or low hanging tree branches, before entering or leaving buildings, or in any other situation where the operator may be struck or pulled from the unit, which could result in serious injury.
20. Disengage all attachment clutches, thoroughly depress the brake pedal and shift into neutral before attempting to start the engine.
21. Your mower is designed to cut normal residential grass of a height no more than 10". Do not attempt to mow through unusually tall, dry grass (e.g. pasture) or piles of dry leaves. Debris may build up on the mower deck or contact the engine exhaust presenting a potential fire hazard.
22. Use only accessories approved for this machine by *Cub Cadet*. Read, understand and follow all instructions provided with the approved accessory.

II. SLOPE OPERATION

Slopes are a major factor related to loss of control and tip-over accidents, which can result in severe injury or death. **All** slopes require extra caution. If you cannot back up the slope or if you feel uneasy on it, do not mow it.

For your safety, use the slope gauge included as part of this manual to measure slopes before operating this unit on a sloped or hilly area. If the slope is greater than 15° as shown on the slope gauge, do not operate this unit on that area or serious injury could result.

DO:

Mow up and down slopes, not across.

Remove obstacles such as rocks, limbs, etc.

Watch for holes, ruts or bumps. Uneven terrain could overturn the machine. **Tall grass can hide obstacles.**

Use slow speed. Choose a low enough gear so that you will not have to stop or shift while on the slope. Always keep the machine in gear when going down slopes to take advantage of engine braking action.

Follow the manufacturer's recommendations for wheel weights or counterweights to improve stability.

Use extra care with grass catchers or other attachments. These can change the stability of the machine.

Keep all movement on the slopes **slow** and **gradual**. Do not make sudden changes in speed or direction. Rapid engagement or braking could cause the front of the machine to lift and rapidly flip over backwards, which could cause serious injury.

Avoid starting or stopping on a slope. If the tires lose traction, disengage the blades and proceed slowly **straight** down the slope.

DO NOT:

Do not turn on slopes unless necessary; then, turn slowly and gradually downhill, if possible.

Do not mow near drop-offs, ditches or embankments. The mower could suddenly turn over if a wheel is over the edge of a cliff or ditch, or if an edge caves in.

Do not mow on wet grass. Reduced traction could cause sliding.

Do not try to stabilize the machine by putting your foot on the ground.

Do not use the grass catcher on steep slopes.

III. CHILDREN

Tragic accidents can occur if the operator is not alert to the presence of children. Children are often attracted to the machine and the mowing activity. **Never** assume that children will remain where you last saw them.

1. Keep children out of the mowing area and in watchful care of an adult other than the operator.
2. Be alert and turn the machine off if children enter the area.
3. Before and when backing up, look behind and **down** for small children.
4. Never carry children, even with the blades off. They may fall off and be seriously injured or may interfere with safe machine operation.

5. Never allow children under 14 years old to operate the machine. Children 14 years and over should only operate the machine under close parental supervision and proper instruction.
6. Use extra care when approaching blind corners, shrubs, trees or other objects that may obscure your vision of a child or other hazard.
7. Remove the key when the machine is left unattended to prevent unauthorized operation.



IV. SERVICE

1. Use extreme care in handling gasoline and other fuels. They are extremely flammable and the vapors are explosive.
 - a. Use only an approved container.
 - b. Never remove fuel cap or add fuel with the engine running. Allow the engine to cool at least two minutes before refueling.
 - c. Replace the fuel cap securely and wipe off any spilled fuel before starting the engine as it may cause a fire or explosion.
 - d. Extinguish all cigarettes, cigars, pipes and other sources of ignition.
 - e. Never refuel the machine indoors because fuel vapors will accumulate in the area.
 - f. Never store the fuel container or machine inside where there is an open flame or spark, such as a gas hot water heater, space heater or furnace.
2. Never run a machine inside a closed area.
3. To reduce fire hazard, keep the machine free of grass, leaves or other debris build-up. Clean up oil or fuel spillage. Allow the machine to cool at least 5 minutes before storing.
4. Before cleaning, repairing or inspecting, make certain the blade and all moving parts have stopped. Disconnect the spark plug wire, and keep the wire away from the spark plug to prevent accidental starting.
5. Check the blade and engine mounting bolts at frequent intervals for proper tightness. Also visually inspect blades for damage (e.g., excessive wear, bent, cracked). Replace with blades which meet original equipment specifications.
6. Keep all nuts, bolts and screws tight to be sure the equipment is in safe working condition.
7. Never tamper with safety devices. Check their proper operation regularly. Use all guards as instructed in this manual.
8. After striking a foreign object, stop the engine, remove the wire from the spark plug and thoroughly inspect the mower for any damage. Repair the damage before restarting and operating the mower.
9. Grass catcher components are subject to wear, damage and deterioration, which could expose moving parts or allow objects to be thrown. For your safety protection, frequently check the components and replace with manufacturer's recommended parts when necessary.
10. Mower blades are sharp and can cut. Wrap the blades or wear gloves, and use extra caution when servicing blades.
11. Check brake operation frequently. Adjust and service as required.
12. Muffler, engine and belt guards become hot during operation and can cause a burn. Allow to cool down before touching.
13. Do not change the engine governor settings or overspeed the engine. Excessive engine speeds are dangerous.
14. Observe proper disposal laws and regulations. Improper disposal of fluids and materials can harm the environment and the ecology.
 - a. Prior to disposal, contact your local Environmental Protection Agency to determine the proper method for disposing of the waste. Recycling centers are established to properly dispose of materials in an environmentally safe fashion.
 - b. Use proper containers when draining fluids. Do not use food or beverage containers that may mislead someone into drinking from them. Properly dispose of the containers immediately following the draining of fluids.
 - c. DO NOT pour oil or other fluids into the ground, down a drain or into a stream, pond, lake, or other body of water. Observe Environmental Protection Agency regulations when disposing of oil, fuel, coolant, brake fluid, filters, batteries, tires and other harmful waste.
15. We do not recommend the use of a pressure washer or garden hose to clean your unit. They may cause damage to electrical components; spindles; pulleys; bearings; or the engine. The use of water will result in shortened life and reduce serviceability.



WARNING - YOUR RESPONSIBILITY: Restrict the use of this power machine to persons who read, understand and follow the warnings and instructions in this manual and on the machine.

PRODUCT GRAPHICS

Keep product safety graphics (decals) clean. Replace any safety graphic that is damaged, destroyed, miss-

ing, painted over or can no longer be read. Replacement safety graphics are available through your dealer.

STARTING INSTRUCTIONS

1. BE FAMILIAR WITH CONTROLS BEFORE STARTING ENGINE AND OPERATING.
2. SET CHOKE, MOVE THROTTLE TO MID POSITION AND DEPRESS BRAKE PEDAL.
3. TURN KEY TO THE START POSITION.
4. AFTER ENGINE STARTS OPEN CHOKE.

STOPPING INSTRUCTIONS

1. DISENGAGE PTO AND SET PARKING BRAKE.
2. MOVE THROTTLE CONTROL TO MID POSITION AND TURN KEY OFF.

WARNING

- AVOID SERIOUS INJURY OR DEATH.
- READ OPERATOR'S MANUAL AND ALL WARNING LABELS BEFORE USING MACHINE.
- GO UP AND DOWN SLOPES, NOT ACROSS.
- AVOID SUDDEN TURNS.
- DO NOT OPERATE UNIT WHERE IT COULD SLIP OR TIP.
- IF MACHINE STOPS GOING UPHILL, STOP PTO AND BACK DOWN HILL SLOWLY.
- DO NOT MOW WHEN CHILDREN OR OTHERS ARE AROUND.
- NEVER CARRY CHILDREN.
- LOOK DOWN AND BEHIND BEFORE AND WHILE BACKING.
- KEEP SAFETY DEVICES (GUARDS, SHIELDS, AND SWITCHES) IN PLACE AND WORKING.
- REMOVE OBJECTS THAT COULD BE THROWN BY THE BLADES.
- KNOW LOCATION AND FUNCTION OF ALL CONTROLS.
- BE SURE THE BLADES AND THE ENGINE ARE STOPPED BEFORE PLACING HANDS OR FEET NEAR BLADES.
- BEFORE LEAVING OPERATOR'S POSITION, DISENGAGE PTO, ENGAGE BRAKE LOCK, SHUT OFF ENGINE AND REMOVE KEY.

GENERAL SAFETY INSTRUCTIONS WARNING – LOCATED ON RIGHT SIDE OF RUNNING BOARD

DANGER

AVOID SERIOUS INJURY OR DEATH

- KEEP HANDS AND FEET AWAY FROM ROTATING PARTS.
- REMOVE OBJECTS THAT CAN BE THROWN BY THE BLADE IN ANY DIRECTION, WEAR SAFETY GLASSES.
- DO NOT MOW WHEN CHILDREN OR OTHERS ARE AROUND. NEVER CARRY CHILDREN.
- USE EXTRA CAUTION ON SLOPES. DO NOT MOW SLOPES GREATER THAN 15° MOW UP AND DOWN, NOT ACROSS. AVOID SUDDEN TURNS, USE LOW GEAR.

MAX 15°

READ OPERATOR'S MANUAL. KEEP SAFETY DEVICES WORKING.

SAFETY GRAPHIC – LOCATED ON LEFT SIDE OF MOWER DECK

DANGER

KEEP HANDS AND FEET AWAY. DO NOT OPERATE MOWER UNLESS CHUTE DEFLECTOR OR ENTIRE GRASS CATCHER IS IN ITS PROPER PLACE.

ASSEMBLE CHUTE DEFLECTOR TO THIS UNIT BEFORE OPERATING.

DEFLECTOR and SAFETY GRAPHIC – LOCATED ON RIGHT SIDE OF DECK

TO REDUCE THE RISK OF INJURY, DO NOT OPERATE MOWER UNLESS DISCHARGE CHUTE COVER OR GRASS CATCHER IS IN ITS PROPER PLACE.

DANGER

KEEP HANDS and FEET AWAY

HANDS AND FEET SAFETY GRAPHIC – LOCATED ON DEFLECTOR CHUTE

CAUTION

- UNDER SPRING TENSION
- HOLD LEVER SECURELY
- REFER TO OPERATOR'S MANUAL

SAFETY GRAPHIC – LOCATED ON LEFT SIDE OF DECK

TO THE OWNER

This Operator's Manual is an important part of your new tractor. The information contained in this manual has been prepared in detail to help you better understand the features, correct operation, adjustments, and maintenance of your tractor. The performance and dependability of this tractor rely greatly on the manner in which it is operated and maintained. Therefore, it is recommended that all operators of the tractor carefully read this manual and fully understand its operation. Also keep the manual available for reference to ensure proper operation, and that maintenance procedures are performed as scheduled to assure the tractor's optimal mechanical condition.

NOTE: All references to *LEFT*, *RIGHT*, *FRONT*, and *REAR*, unless specifically stated otherwise, indicate that relative position on the tractor when facing forward while seated in the operator's seat.

CAUTION: DO NOT tow your Model GT 2186 tractor. Towing may damage the transmission. Place the tractor on a LEVEL SURFACE before pulling the transmission release lever to the disengaged position.

Your local authorized *Cub Cadet* dealer is interested in the performance you receive from your tractor, and with the maintenance needed to ensure the satisfactory operation of your tractor. The dealer has trained service personnel familiar with the latest servicing information, is equipped with the latest tools, and has a complete line of genuine *Cub Cadet* service parts which assure proper fit and high quality.

CALLING SERVICE INFORMATION

The engine manufacturer is responsible for all engine-related issues with regards to performance, power-rating, and specifications.

If you have difficulties with the tractor and/or equipment; have any questions regarding the operation or maintenance of this equipment; or desire additional information not found in this manual, contact your nearest authorized *Cub Cadet* dealer. If you need assistance in locating a dealer in your area, contact the Customer Dealer Referral Line by calling:

1-877-282-8684

Or you may contact Cub Cadet via the internet by logging on to our Web Site at:

www.cubcadet.com

To obtain top performance and assure economical operation, the tractor should be inspected by your authorized dealer periodically or at least once a year, depending on its hours of use. Before calling your dealer, make sure that you have your model number(s) and manufacturing date available for the dealer.

RECORDING MODEL AND SERIAL NUMBER INFORMATION

Product identification plates are provided for major components of your tractor. The numbers on these plates are important if your tractor should require dealer service, or if you need additional information on your tractor. Prior to using your tractor for the first time, record the numbers from the identification plates in the appropriate spaces provided below.

The chassis model plate, showing the factory model number and Mfg. Date (See Figure 1) can be found on the underside of the seat mounting base. Pivot the seat forward to locate the decal.

The engine serial number decal (See Figure 2) is located on the engine blower housing.

Hood Model _____ Factory Model No. _____ Mfg. Date _____

Delivery Date _____ Engine Model/Spec. No. _____ Engine Serial No. _____

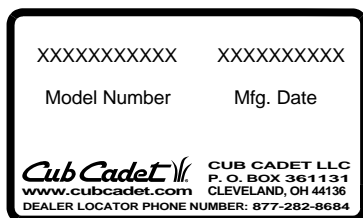

Figure 1

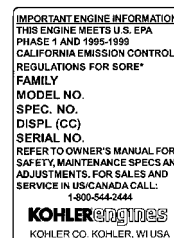
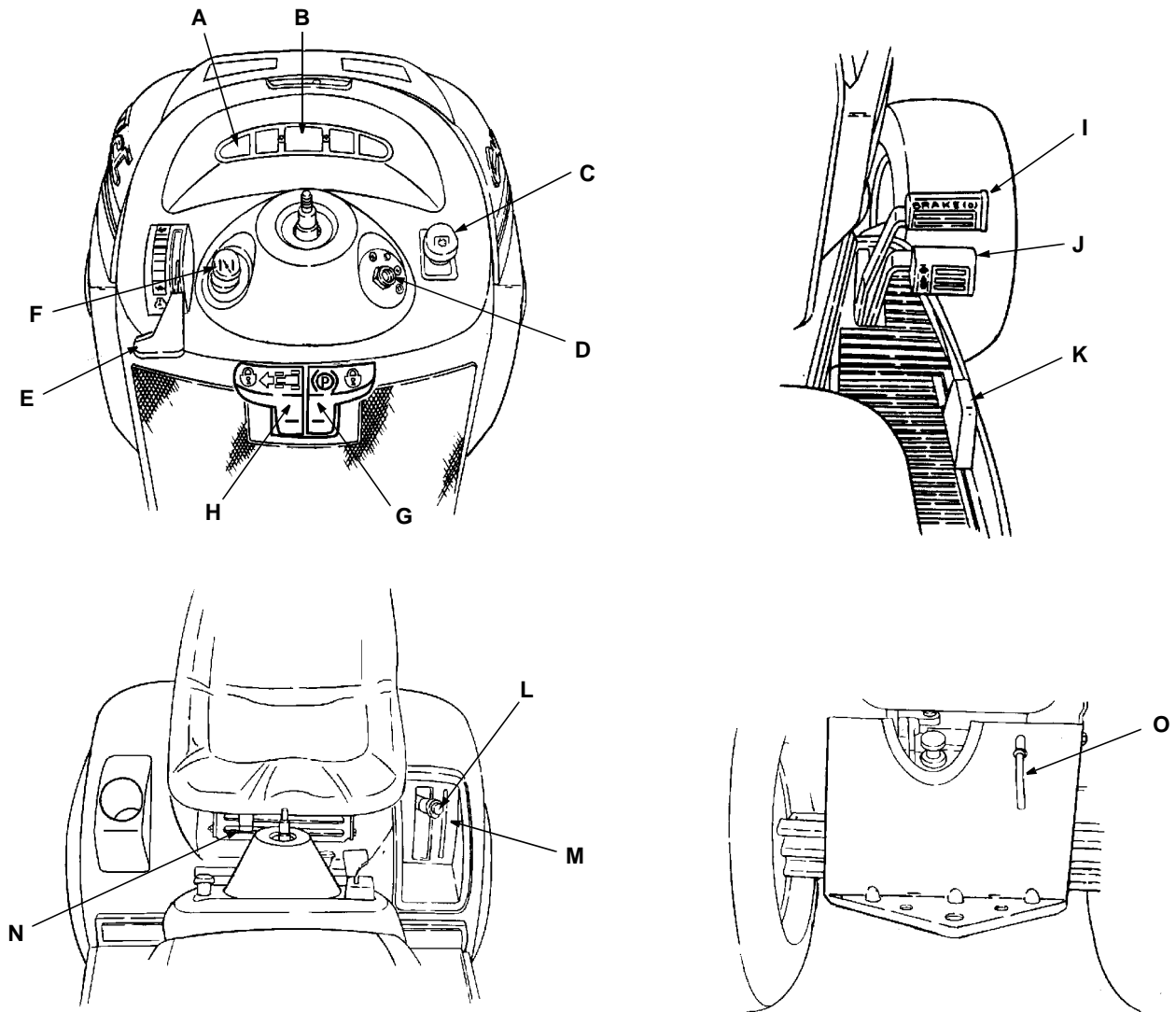

Figure 2

SECTION I. CONTROLS AND INDICATORS

Your Cub Cadet Tractor has been safety engineered. This section gives a brief description of the function and location of the various controls and indicators.

Thoroughly acquaint yourself with all the controls and indicators before attempting to start or operate the tractor.



- A. Low Oil Indicator
- B. Hour Meter
- C. Power Take-Off (PTO) Control Switch
- D. Ignition/Light Switch
- E. Throttle Control Lever
- F. Choke Control
- G. Brake Pedal Lock
- H. Cruise Control Lever

- I. Brake Pedal
- J. Forward Control Pedal
- K. Reverse Control Pedal
- L. Lift Handle
- M. Lift Height Indicator
- N. Seat Adjustment Lever
- O. Transmission Release Lever
- P. Fuses (Not Shown)
- Q. Safety Interlock Switches (Not Shown)

Figure 3

A. LOW OIL INDICATOR

This indicator will illuminate when the engine oil level is low. If this indicator illuminates, stop the tractor immediately and check the engine oil level. If the oil level is within the operating range, but the light remains on, contact your *Cub Cadet* dealer.



CAUTION

Operating the tractor with low oil level or pressure could result in severe engine damage.

B. HOUR METER

The hour meter operates whenever the ignition key is in the "ON" position. Record the actual hours of tractor operation to ensure all maintenance procedures are completed according to the schedule in this manual.

C. POWER TAKE-OFF (PTO) CONTROL SWITCH

The power take-off control switch operates the front electric PTO clutch. Pull the switch knob to engage ("RUN"), or push the knob to disengage ("OFF") the PTO clutch.

D. IGNITION/LIGHT SWITCH



WARNING

To prevent accidental starting and/or battery discharge, remove the key from the ignition switch when the tractor is not in use.

The combination lights and ignition switch is a four position switch. (See Figure 4)

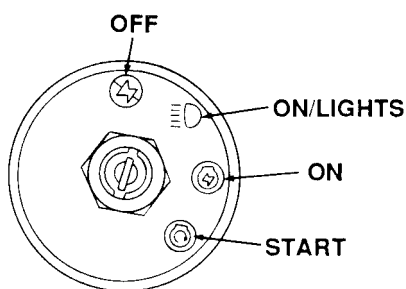

Figure 4

E. THROTTLE CONTROL LEVER

This lever controls the speed of the engine. When set in a given position, the control cable will maintain a uniform engine speed.



NOTE

When using power take-off operated equipment, best performance is achieved with the throttle lever in the "FAST" position.



This symbol shows slow position.



This symbol shows fast position.

F. CHOKE CONTROL

The choke control is operated manually. Pull the knob out to choke the engine; push the knob in to open the choke.

G. BRAKE PEDAL LOCK



WARNING

The hydrostatic transmission will not hold the tractor on a hill. Normal internal leakage in the transmission will allow the tractor to roll downhill. To avoid an accident and/or possible injury, engage the brake pedal lock.

The brake lock lever, located in the center of the dash panel below the steering wheel, is identified with the (P) symbol. Always engage the brake pedal lock when dismounting the tractor. To engage the brake pedal lock, depress the brake pedal and push down on the brake pedal lock lever. Hold the lever down while releasing the brake pedal. The lever should lock in the down position.

H. CRUISE CONTROL LEVER

The cruise control lever, located in the center of the dash panel below the steering wheel, is identified with the  symbol. This lever can be used to maintain a desired "foot free" **forward speed** in areas where constant speed changes are not required. Refer to **Section II- OPERATION** for instructions on how to use this feature.

I. BRAKE PEDAL

The brake pedal is located at the front of the right running board above the forward control pedal. Press down to stop the tractor and disengage the cruise control. The brake pedal must be fully depressed to activate the safety interlock switch when starting the tractor.

J. FORWARD CONTROL PEDAL

The forward control pedal is located at the front of the right running board below the brake pedal. Slowly press down on the pedal to start moving forward. The forward ground speed of the tractor is directly affected by the distance the pedal is depressed.

K. REVERSE CONTROL PEDAL



WARNING

Check behind the tractor to be sure the area is clear of people, pets or obstacles. Use a slower speed to maintain control of the tractor when traveling in reverse.

The reverse control pedal is located in the right front running board rearward of the the brake and forward control pedals. Press the pedal downward to move in reverse.

L. LIFT HANDLE

The lift handle is located in the left fender and is used to raise and lower equipment used with the tractor. The equipment can be set in any of six positions by depressing the top button on the handle, moving the handle to the desired position, then releasing the button. It may be necessary to push or pull slightly on the handle to depress the button. There is a lift assist spring which reduces the effort needed to lift attachments. To adjust spring tension refer to **ADJUSTMENTS** in Section III.

M. LIFT HEIGHT INDICATOR

The lift height indicator is located in the left fender and indicates the height of the deck attachment when installed.

N. SEAT ADJUSTMENT LEVER

The seat adjustment lever (see Figure 5) is used to move the seat forward or rearward into one of five positions. See **ADJUSTING THE SEAT** in Section III.

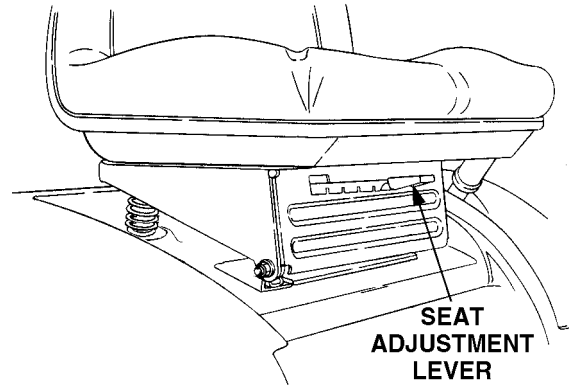

Figure 5

O. TRANSMISSION RELEASE LEVER

The transmission release lever is located at the back of the tractor in the rear drawbar. This lever disconnects the hydro transmission pump from the rear axle to allow the unit to be pushed a short distance by hand.

To disengage the transmission, pull back on the lever until its locking flange is visible outside the drawbar, then lift the lever up into the slot and release. To re-engage the transmission, pull back on the lever, drop out of the slot and release.

P. FUSES

The fuses are located under the hood between the indicator lamps and the hour meter (see Figure 6). Fuses are installed to protect the tractor's electrical circuitry and components from damage caused by excessive amperage.

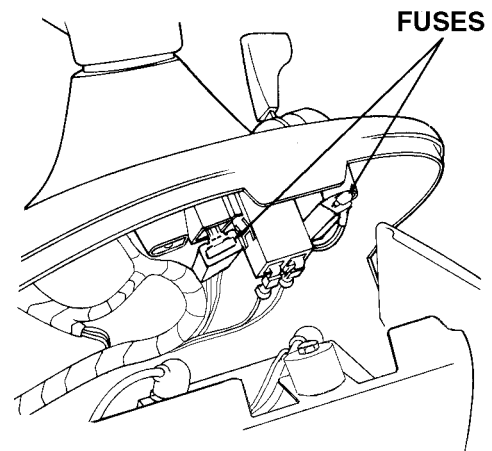

Figure 6

Q. SAFETY INTERLOCK SWITCHES

This tractor is equipped with a safety interlock system for the protection of the operator. If the interlock system should ever malfunction, do not operate the tractor. Contact your authorized *Cub Cadet* Dealer. The safety interlock system prevents the engine from cranking or starting unless the brake pedal is fully depressed, and the PTO switch is in the "OFF" position.

The safety interlock system will automatically shut off the engine if the operator leaves the seat before engaging the brake lock.

The safety interlock system will automatically shut off the engine if the operator leaves the seat with the PTO in the "RUN" position, regardless of whether the brake lock is engaged. The PTO switch must be moved to the "OFF" position to restart the engine.

The safety interlock system will automatically shut off the PTO if the *reverse control pedal* is depressed with the PTO in the "RUN" position. To re-engage the PTO, release the reverse control pedal, move the PTO switch to the "OFF" position, then again pull the switch to the "RUN" position.

FUEL TANK

The fuel tank is located under the rear fender. The filler cap is in the center/rear of the fender (see Figure 7).

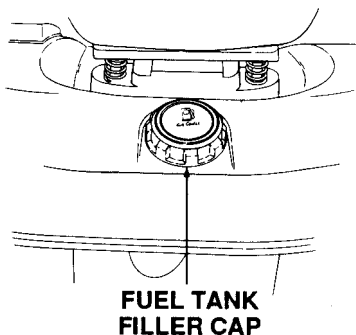

Figure 7

HOOD AND SIDE PANELS

The tractor hood is arranged to swing up and forward for easy access to the engine compartment (see Figure 8). Whenever engine maintenance is required, the side panels can be removed.



WARNING

If the engine has been recently run, the engine, muffler and surrounding metal surfaces will be hot and can cause burns to the skin. Allow the tractor to cool and use caution when removing the side panels.

To remove either the right or left side panel, refer to Figure 8 and proceed as follows:

1. Engage the brake lock and raise the hood.
2. Loosen, but do not remove, the rear wing nut and upper front wing nut.
3. Grasp the side panel just behind the grille and pull outward to release the side panel from the tapered bushings on the grille.
4. Slide the side panel forward and out of the groove in the dash panel.

To install either the right or left side panel, refer to Figure 8 and proceed as follows:

1. Slide the rear of panel into the groove in the dash panel.
2. Position the notch of the rear side panel tab on the threads of the bulkhead rod, between the bulkhead and wing nut.
3. Press the slots of the front side panel flange onto the tapered retainers, between the retainers and the grille.
4. Tighten the rear and upper front wing nuts and close the hood.

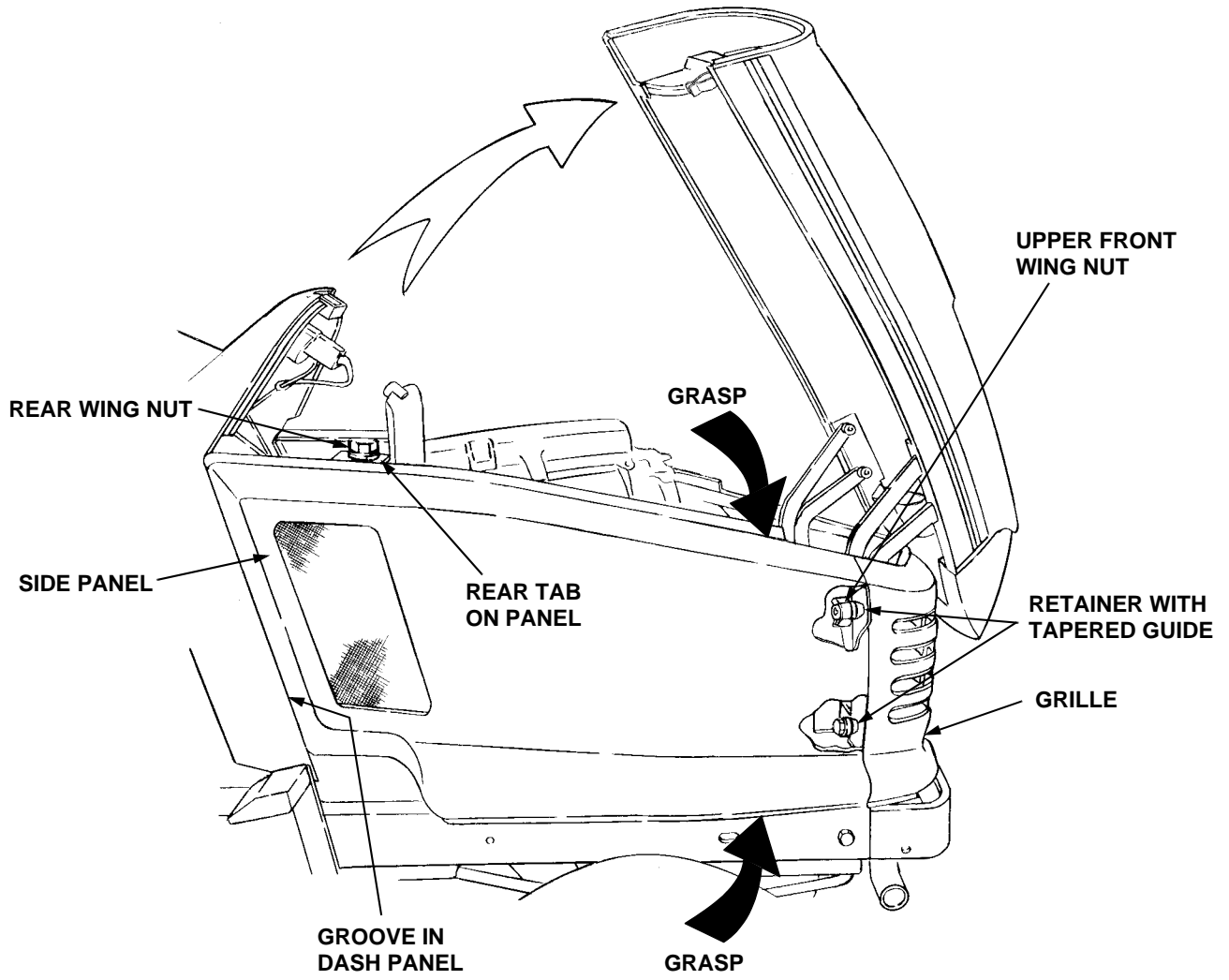

Figure 8

SECTION II. OPERATION



WARNING

RECEIVE INSTRUCTION - Read the operator's manual. Learn to operate this machine SAFELY. Don't risk INJURY or DEATH.

1. Before starting the engine or beginning operation, be familiar with the controls. The operator must be seated, the PTO switch in the "OFF" position and the brake pedal fully depressed.
2. Keep all shields in place. Keep away from moving parts.
3. NO RIDERS! Keep all people and pets a safe distance away. Look behind to both sides before backing up.
4. DO NOT direct the mower discharge at people.
5. Avoid slopes. Tractors can be rolled over.
6. Before leaving the operator's seat: Shut off the PTO, engage the brake pedal lock, shut off the engine and remove the ignition key. Wait for all movement to stop before servicing or cleaning.
7. Do not fill the fuel tank when the engine is running or while the engine is hot. Tighten the fuel cap securely.

BEFORE OPERATING YOUR TRACTOR

1. Before you operate the tractor, study this manual carefully. It has been prepared to help you operate and maintain your tractor with utmost efficiency.
2. Familiarize yourself with the operations of all the instruments and controls.
3. This engine is certified to operate on unleaded gasoline. For best results, fill the fuel tank with only clean, fresh, unleaded gasoline with a pump sticker octane rating of 87 or higher. In countries using the Research method, it should be 90 octane minimum.

Unleaded gasoline is recommended because it leaves less combustion chamber deposits. Lead-ed gasoline may be used in areas where unleaded is not available and exhaust emissions are not regulated. Be aware however, that the cylinder head may require more frequent service.

Gasohol (up to 10% ethyl alcohol, 90% unleaded gasoline by volume) is an approved fuel. Other gasoline/alcohol blends are not approved.

Methyl Tertiary Butyl Ether (MTBE) and unleaded gasoline blends (up to a maximum of 15% MTBE by volume) are approved fuels. Other gasoline/ether blends are not approved.

4. Check the engine and transmission oil levels.
5. Clean the air cleaner element if necessary.
6. Check the tire inflation pressures.
7. Adjust the seat for operator's maximum comfort, visibility and for maintaining complete control of the tractor.
8. Remove the side panels and clean any accumulated grass and debris from the engine air inlet screen. Also clean the dash air intake screen, grille and side panels to ensure adequate cooling.
9. Refer to the various sections of the Owner's Manual for additional information.

STARTING THE ENGINE



WARNING

For personal safety, the operator must be sitting in the tractor seat when starting the engine.



WARNING

This unit is equipped with a safety interlock system designed for the protection of the operator. Do not operate the tractor if any part of the interlock system is malfunctioning. Periodically check the functions of the interlock system for proper operation as described below:

- The safety interlock system prevents the engine from cranking or starting unless the brake pedal is fully depressed and the PTO clutch engagement switch is in the "OFF" position.

- The safety interlock system will automatically shut off the engine if the operator leaves the seat before engaging the brake pedal lock.
- The safety interlock system will automatically disengage the PTO if the reverse control pedal is pressed down with the PTO in the “RUN” position. To re-engage the PTO, release the reverse control pedal, move the PTO switch into the “OFF” position and then engage the PTO while seated.
- The safety interlock system will automatically shut off the tractor engine if the operator leaves the seat with the PTO in the “RUN” position.

1. Operator must be sitting in the tractor seat.
2. Pull choke control knob to full choke position. Less choking may be necessary due to variations in temperature, grade of fuel, etc. Little or no choking will be needed when the engine is warm.
3. Place the throttle midway between the “SLOW” and “FAST” position.
4. Place the PTO switch in the “OFF” position.
5. Fully depress the brake pedal.
6. Turn the ignition key clockwise to the “START” position and release it as soon as the engine starts; however, do not crank the engine continuously for more than 10 seconds at a time. If the engine does not start within this time, turn the key “OFF” and wait a minute to allow the engine’s starter motor to cool, then try again.
7. After the engine starts, slowly release the brake pedal. As the engine warms up, gradually push the choke control knob all the way in. Do not use the choke to enrich the fuel mixture, except as necessary to start the engine.

STOPPING THE ENGINE



CAUTION

Remove the key from the ignition switch to prevent accidental starting or battery discharge if the equipment is left unattended.

Place the PTO switch in the “OFF” position. Move the throttle control lever between the “MID” and “FAST” positions. Wait a moment to allow the engine speed to stabilize, then turn the ignition key to the “OFF” position. Remove the key from the ignition switch.

TRACTOR BREAK-IN PROCEDURE



CAUTION

Never operate a new engine immediately under full load. Break it in carefully as shown in the table below.

Period	Engine Throttle Control Lever Position			Load
	½	¾	Full	
1st hour		X		None
2 hour	X		X	Light drawbar load or Mowing with tractor at slow speed
3rd through 13th hour		X	X	Medium draw- bar load or Normal mowing

COLD WEATHER STARTING



WARNING

Engine exhaust gases are dangerous. Do not run the engine in a confined area such as a storage building any longer than is necessary. Immediately move the tractor outdoors.



WARNING

For personal safety, the operator must be sitting in the tractor seat before starting the tractor.

When starting the engine at temperatures near or below freezing, ensure the correct viscosity motor oil is used in the engine and the battery is fully charged. Start the engine as follows:

1. Pull the choke all the way out to full choke position.
2. Move the throttle control lever to midway between the “SLOW” and “FAST” position.
3. Place the PTO switch in the “OFF” position.
4. Fully depress the brake pedal.

5. Turn the ignition key to the "START" position and hold until the engine starts; however, do not crank the engine continuously for more than 10 seconds at a time. Once the engine starts, gradually adjust the choke as needed to keep the engine running until warmed up, then push the choke control all the way in.

NOTE

If the engine fails to start after several attempts, the engine may become flooded. If this happens, wait a minute to allow the starter motor to cool. Move the throttle control to the "SLOW" position, push the choke in all the way and momentarily crank the engine to help clear the cylinders. With the throttle control in the "SLOW" position and the choke all the way in, turn the ignition key to the "START" position while slowly pulling the choke out to a position that will allow the engine to start. Gradually adjust the choke as needed to keep the engine running until warmed up, then push the choke control all the way in.

DRIVING THE TRACTOR

CAUTION

Avoid sudden starts, excessive speed and sudden stops.

CAUTION

Do not leave the seat of the tractor without disengaging the PTO, depressing the brake pedal and engaging the brake pedal lock. If leaving the tractor unattended, also turn the ignition key off and remove the key.

NOTE

When using power take-off operated equipment, best performance is achieved with the throttle lever in the "FAST" position.

1. Depress the brake pedal to release the brake pedal lock and let the pedal up. Move the throttle lever to the position where the engine operates best for the load to be handled.
2. Driving with forward or reverse pedals.

CAUTION

Do not use the forward or reverse control pedals to change the direction of travel when the tractor is in motion. Use the brake pedal to bring the tractor to a stop before depressing either the forward or reverse control pedal.

- a. To move forward, slowly depress the forward control pedal until the desired speed is achieved.
 - b. To move in reverse, check that the area behind is clear then fully depress the reverse control pedal.
3. Using the cruise control lever.

NOTE

The cruise control feature can only be operated in the forward direction.

- a. Slowly depress the forward control pedal until the desired speed is achieved.
- b. Lightly push the cruise control lever downward as far as possible and hold in this position.
- c. While continuing to hold the cruise lever down, lift your foot from the forward control pedal (you should feel the cruise latch engage).
- d. If properly engaged, the cruise lever and forward control pedal should lock in the down position, and the tractor will maintain the same forward speed.
- e. Disengage the cruise control using one of the following methods:
 - Depress the brake pedal to disengage the cruise control and stop the tractor.
 - Lightly depress the forward control pedal.
 - Lift the cruise control lever upward.

NOTE

Although not recommended, depressing the reverse pedal will also disengage the cruise control.

- f. To change to the reverse direction when operating with cruise control, depress the brake pedal to disengage the cruise control and stop the tractor; then depress the reverse control pedal.

DRIVING ON SLOPES

Refer to the SLOPE GAUGE on page 55 to help determine slopes where you may not operate safely.



WARNING

Do not mow on inclines with a slope in excess of 15 degrees (a rise of approximately 2-1/2 feet every 10 feet). The tractor could overturn and cause serious injury.



WARNING

Operate the tractor up and down slopes, never across slopes. Always drive up or down the face of a slope. Do not drive so that the tractor may tip over sideways.

Before operating the tractor on any slope, walk the slope to look for possible hazards such as rocks, mounds, ruts, stumps or other surface irregularities which could cause the tractor to be upset.

Back the tractor with implement up the steepest portion of each slope you intend to work. If the tractor cannot negotiate the slope in reverse, the slope is too steep to be worked.

Avoid turns when driving on a slope. If a turn must be made, turn **down** the slope. Turning up a slope greatly increases the chance of a roll over.

Avoid stopping when driving up a slope. If it is necessary to stop while driving up a slope, start up smoothly and carefully to reduce the possibility of flipping the tractor over backward.

STOPPING THE TRACTOR



CAUTION

Always engage the brake pedal lock, push the PTO switch to the "OFF" position, lower the equipment and shut off the engine before dismounting. Never try to start the engine while standing on the ground.

Fully depress the brake pedal to bring the tractor to a complete stop (and disengage the cruise control), engage the brake pedal lock, disengage the PTO, turn the ignition switch to "OFF" and remove the key from the switch before dismounting.

OPERATING THE POWER TAKE-OFF (PTO) CLUTCH

Before operating the new clutch under load (mowing grass, etc.), perform the following break-in procedure:

1. Start and run the engine a few minutes to warm up.
2. With the mowing deck, snow thrower, etc. installed and the engine running at approximately 50% throttle, engage and disengage the clutch at ten second intervals (ten seconds ON-ten seconds OFF) five times. The engine choke may have to be pulled out slightly to accomplish this.
3. Increase the engine speed to 75% throttle and again engage and disengage the PTO clutch at ten second intervals five times.
4. Make certain the PTO is disengaged and stop the engine.

Operate the PTO clutch as follows:

1. Move the throttle control lever to approximately the mid throttle position.
2. Pull the PTO switch to the "RUN" position.
3. Advance the throttle lever to the operating speed (full engine speed).
4. The operator must remain in the tractor seat at all times. If the operator should leave the seat without turning off the power take-off switch, the tractor's engine will shut off.
5. The PTO clutch cannot be operated when the tractor is driving in the reverse direction. The PTO switch must be in the "OFF" position when the reverse control pedal is depressed, or the PTO clutch will automatically disengage. To re-engage the PTO clutch, release the reverse control pedal, move the PTO switch to the "OFF" position, then again pull the switch to the "RUN" position.

DRAWBAR

Drawbar type equipment must be hitched to the tractor only at the hitch hole in the drawbar (See Figure 9).

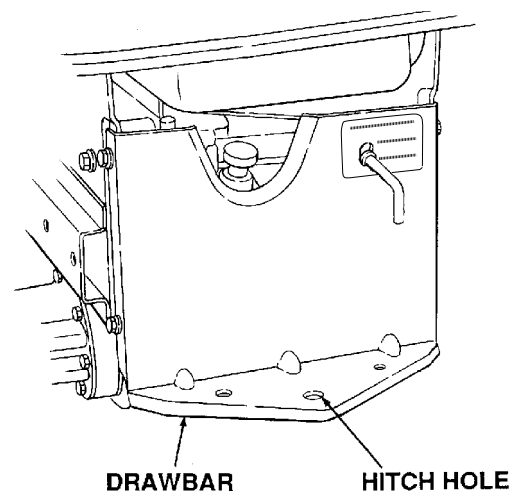

Figure 9

SECTION III. ADJUSTMENTS

This section contains adjustment information for the Model GT 2186 tractor. Adjustment information for the 44-inch deck is located in Section V – Mower Deck beginning on page 33.

ADJUSTING THE SEAT



WARNING

Do not adjust the seat when the tractor is moving. Adjusting the seat while the tractor is moving could cause the operator to lose control of the tractor.

Before starting the tractor, adjust the seat forward or rearward to the most comfortable driving position. To reposition the seat, move the seat adjustment lever (see Figure 10) upward and slide the seat forward or rearward. Release the adjustment lever when the seat is comfortably positioned. Gently rock the seat forward or rearward to be sure the seat is locked in place.

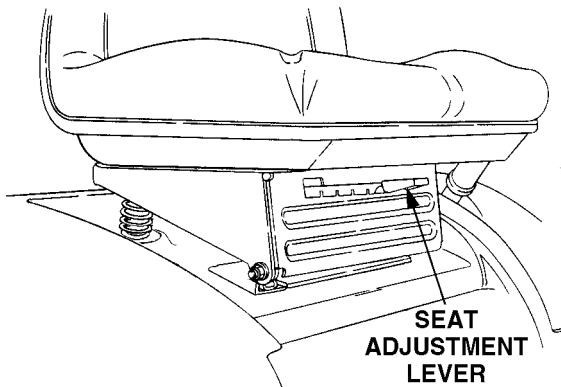

Figure 10

ADJUSTING THE BRAKES

During normal operation of this tractor, the brakes are subject to wear and will need periodic examination and adjustment.

To check the brake adjustment, position the tractor on a firm and level surface. Stop the tractor engine and remove the ignition key. Pull and lock the transmission release lever in the “TRANSMISSION RELEASED” position. Perform the following checks:

1. Engage the brake pedal lock. If the tractor can be pushed forward or rearward, the braking force must be increased.
2. Release the brake pedal lock. If the tractor cannot be pushed forward or rearward, the braking force must be decreased.

To adjust the braking force, refer to Figure 11 and proceed as follows:

1. Place the tractor on a level surface with the brake pedal lock disengaged. Stop the tractor engine and remove the ignition key.
2. While working from the underside of the tractor, facing the threaded end of the rod:
 - Remove the internal cotter pin from the brake rod adjustment ferrule and disconnect the ferrule from the brake cam.
 - Loosen the hex jam nut from against the ferrule.

To increase the braking force—

Turn the ferrule clockwise (inward) one full turn at a time until the ferrule can be inserted into the brake cam while applying a **minimal tension** on the spring.

To decrease the braking force—

Turn the ferrule counterclockwise (outward) one full turn at a time until the ferrule can be inserted into the brake cam while applying a **minimal tension** on the spring.

3. Turn the ferrule counterclockwise (outward) one full turn to release the slight spring tension. Tighten the jam nut against the ferrule, then insert the ferrule into the brake cam and secure with the internal cotter pin.

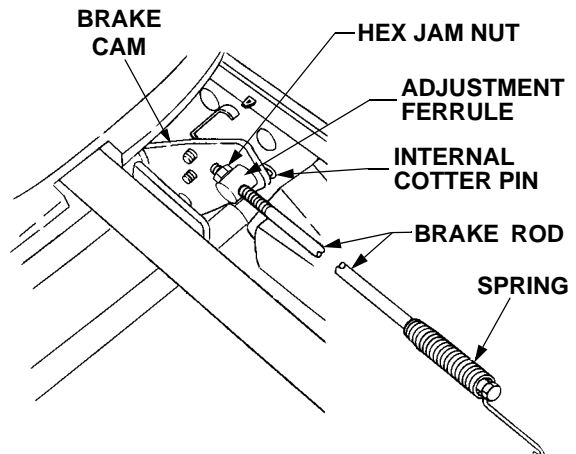

Figure 11. Viewed from top (fender off).

Recheck the brake adjustment to ensure proper brake operation before operating the tractor. If brake rod adjustment does not correct the problem, see your authorized *Cub Cadet* dealer.

WHEEL ALIGNMENT

The front wheels should toe-in approximately 1/8 to 1/4 inch, as measured across dimensions A and B shown in Figure 12.

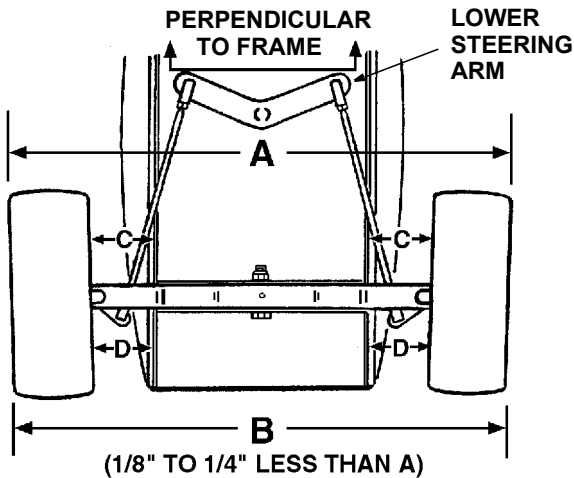

Figure 12. Viewed from beneath the tractor.

FRONT WHEEL ADJUSTMENT



WARNING

Place the tractor on a firm and level surface.

To adjust the toe-in, proceed as follows:

1. Check the lower steering arm to ensure it is perpendicular to the tractor frame (See Figure 12).
2. Place a mark at the same spot on both front wheels; preferably the inner bead flange of the wheel rims.
3. Rotate the wheels to position the marks at the front *horizontal* diameter of the wheels, then measure the distance between the marks and the bottom edges of the tractor frame channels (See measurement D in Figure 12). These two measurements should be equal.
4. While holding the steering arms to prevent the steering knuckles from moving, rotate the marks to the rear *horizontal* diameter. Measure the distance between the marks and the frame (See measurement C in Figure 12). Measurement D should be approximately 1/16 to 1/8 inch less than measurement C on each side of the tractor.

5. Disconnect the front ball joints from the steering arms by removing the hex lock nuts (Refer to Figure 13). Manually move each wheel to achieve the required toe-in *and* equal D measurements.
6. Loosen the jam nuts from the ball joints (See Figure 13).

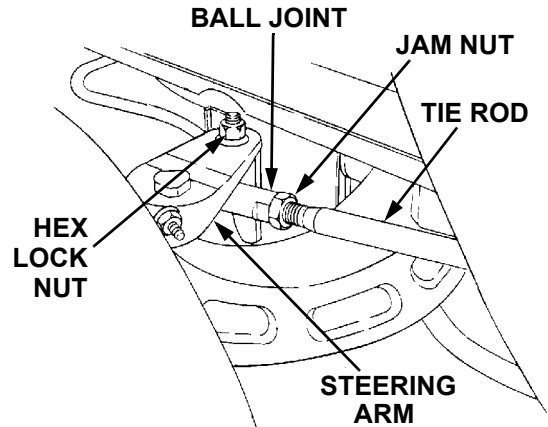

Figure 13

7. Making sure not to move the lower steering arm or either wheel, turn the ball joint in or out on each tie rod as necessary to align with the hole in each steering arm.
8. Reinstall the ball joints in the steering arms and secure with the hex lock nuts. Tighten the jam nuts against the ball joints.

PIVOT BAR ADJUSTMENT



CAUTION

The tractor should be checked every 50 hours of operation for play between the frame axle channel and the pivot axle.

Check and adjust the pivot axle as follows:

1. Raise the front of the tractor and set it on jack stands, so the front wheels are suspended above the ground.



CAUTION

For safety, block the rear wheels to prevent the tractor from rolling and tipping or sliding the jack stands.

- Pivot the ends of the axle up and down to check for binding. If the axle is binding, loosen the lock nuts (See Figure 14) until binding is eliminated.

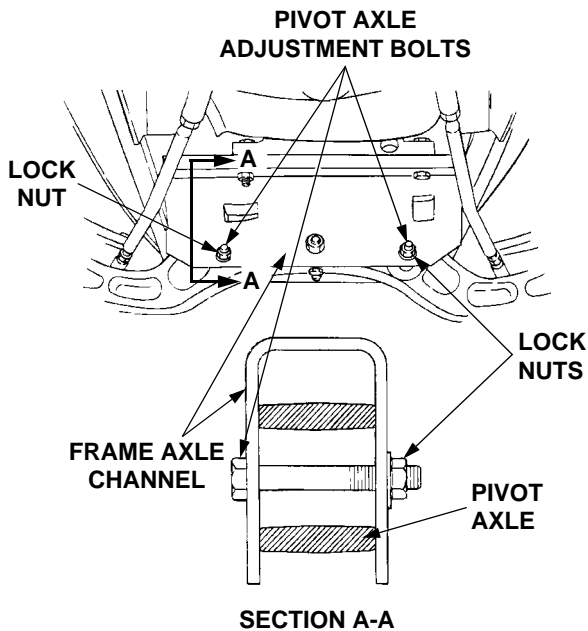

Figure 14

- Grasping the ends of the pivot axle, attempt to move each end of the axle forward and rearward to check for side play between the axle and frame channel. If play is present, gradually tighten the lock nuts until play is minimized.
- Repeat steps 2 and 3 until minimum play without binding is achieved.
- Raise the front of the tractor, remove the jack stands, and lower the tractor to the ground. Remove the blocks from the rear wheels.

HYDROSTATIC NEUTRAL ADJUSTMENT

The following adjustments will be necessary if the tractor creeps forward or rearward when neither the forward nor reverse pedals are depressed.

Checking the Transmission Neutral Setting

To check and adjust the transmission neutral setting, proceed as follows:

- Drive the tractor for approximately 5-10 minutes to warm up the transmission, then stop the engine and engage the parking brake.



WARNING

Place the tractor on a firm and level surface and chock the front wheels before raising the rear wheels from the ground. Use jack stands to support the rear of the tractor when raised.

- Raise the rear of the tractor, so that the rear tires are at least one inch above the surface, and set it on jack stands. Make certain the jack stands are positioned to balance the tractor and prevent tipping.



WARNING

The operator presence safety circuit will stop the engine if the seat is empty when the brake pedal is released. If an assistant is seated when adjusting the neutral setting, use extreme caution to prevent the tractor from tipping or rolling. Similar precautions should be taken with any other method of over-riding the safety circuit, such as placing a weight in the seat. Never operate the tractor with the safety circuit disabled.

- Carefully start the tractor engine and release the parking brake. Observe both rear wheels for rotation in either direction.
- If wheel rotation is observed, adjust the neutral setting as follows:
 - Disconnect the rear control rod from the control arm by removing the hairpin cotter from the pivot sleeve (Refer to Figure 15).
 - If wheel rotation stops when the rod is disconnected, check and readjust the control rod per the instructions below.
 - If wheel rotation continues, loosen the locknut securing the hex cap screw and centering spacer to the neutral bracket (See Figure 15).
 - If the rotation is in the *forward* direction, slide the centering spacer rearward until the wheels just begin to rotate in the *reverse* direction. Then slowly slide the spacer slightly forward until wheel rotation stops.
 - If the rotation is in the *reverse* direction, slowly slide the centering spacer slightly forward until rotation stops.
 - Carefully tighten the hex cap screw and locknut, making certain the centering spacer does not move.
 - Stop the engine and **engage the parking brake**.

1. Front Control Rod
2. Rear Control Rod
3. Hex Tap Screw
4. Pivot Sleeve
5. Neutral Arm
6. Control Arm
7. Hex Cap Screw
8. Centering Spacer
9. Neutral Bracket
10. Hairpin Cotter
(Not Shown)

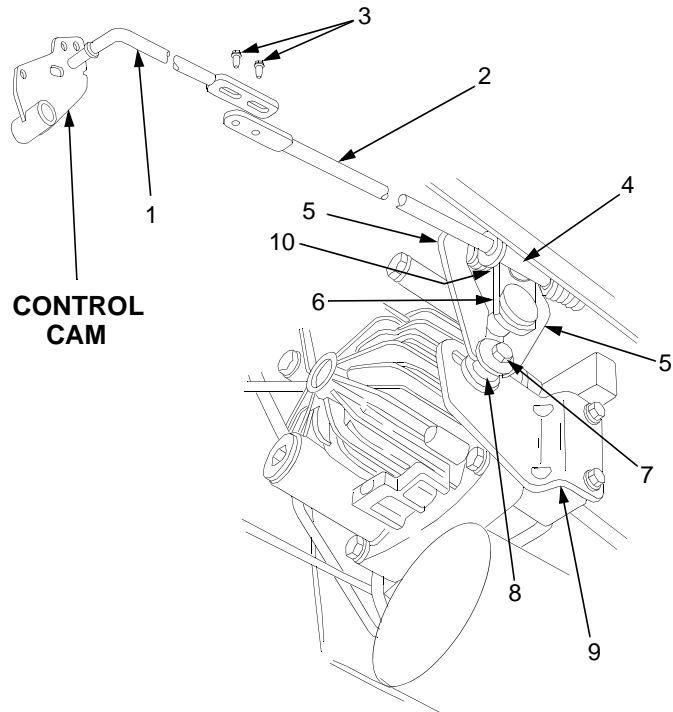

Figure 15.

Adjusting the Control Rod

After completing the previous steps (1 thru 4) for checking neutral setting, adjust the control rod (See Figure 15) as follows:

NOTE

The brake pedal lock **MUST** be engaged to properly adjust the control rod.

1. Loosen, but do not remove, the hex tap screws that fasten the front and rear control rods together.
2. While making certain to not move the front control rod, control cam or control arm (See Figure 15), slide the rear control rod in the direction necessary to directly align the pin of the pivot sleeve with the lower hole of the control arm.
3. Insert the pivot sleeve pin into the control arm and secure with the hairpin cotter, then tighten the hex tap screws. Make sure to maintain the adjusted position of the control rods when tightening the screws.
4. Raise the rear of the tractor, remove the jack stands and lower the tractor.

ADJUSTING LIFT ASSIST SPRING TENSION

The effort required to operate the implement lift handle can be varied by loosening or tightening the lift assist spring adjusting bolt (See Figure 16). The bolt can be accessed from the rear of the tractor, inside the left rear wheel. Turning the adjusting bolt clockwise will decrease the manual effort required for lifting attachments; turning counterclockwise will increase the effort needed to lift the attachment.

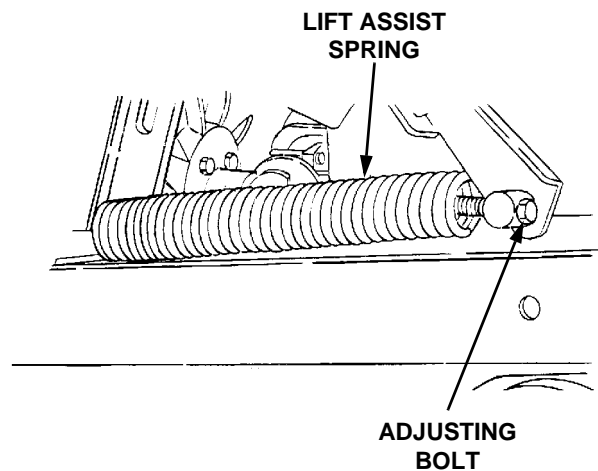

Figure 16

CARBURETOR ADJUSTMENTS



WARNING

When making adjustments to the carburetor while the engine is running, disengage the PTO clutch and engage the brake pedal lock. Keep clear of all moving parts and be careful of all hot surfaces.



WARNING

Carbon monoxide fumes can be fatal! Do not make any adjustments to the carburetor in a confined area such as a storage building. Move the tractor outside into the air.

The carburetor is adjusted at the factory and under normal operating conditions it will not require readjusting. The high idle is set at the factory and cannot be adjusted. If the engine does not operate properly and the problem appears to be fuel system related, check the following areas before adjusting the carburetor: Refer to **MAINTENANCE** section.

- Check for fuel in fuel tank
- Check fuel cap vent for blockage
- Check fuel line for pinched or obstructed areas
- Check for fuel filter blockage
- Check for a clogged air filter

If, however, the engine is hard-starting or runs roughly or stalls at low idle speed, it may be necessary to adjust or service the carburetor.

The air filter element and element cover must be assembled to the carburetor when running the engine.

There are no accessible mixture adjustment screws on the carburetor. The only setting which can be changed is the low idle speed.

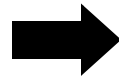

NOTE

Carburetor adjustments should be made only after the engine has warmed up.

1. Start the engine and run at half throttle for 5 to 10 minutes to warm up. The engine must be warm before making the final settings. Check that the throttle and choke plates can fully open.
2. **Idle Speed Setting:** Place the throttle control into the "idle" or "slow" position. Set the low idle speed to **1200 rpm** (± 75 rpm) by turning the low idle speed adjusting screw in or out. Check the speed using a tachometer (See Figure 17).

NOTE: AIR CLEANER COVER MUST BE REMOVED TO ADJUST CARBURETOR IDLE SPEED

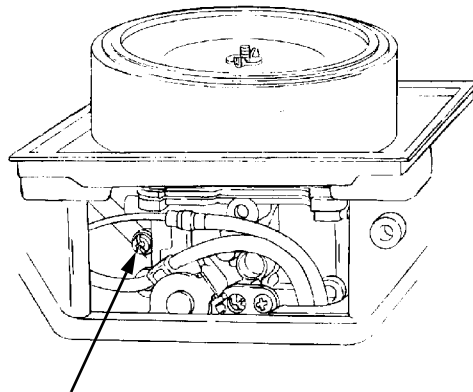

IDLE SPEED ADJUSTING SCREW AND SPRING

Figure 17

3. If proper operation is not restored after adjusting the low idle speed, carburetor servicing by your Cub Cadet dealer may be required.

SECTION IV. MAINTENANCE

ENGINE MAINTENANCE

Maintenance, repair, or replacement of the emission control devices and systems, which are being done at the customer's expense, may be performed by any engine repair establishment or individual. **Warranty repairs must be performed by an authorized Kohler service outlet.**

ENGINE OIL

The engine-crankcase is filled with ship-away oil. This oil may be used for the first 5 hours of engine operation at temperatures between 0° and 90°F. If temperatures are not within this range, drain the oil from the oil filter and crankcase and replace with new oil as specified in the **LUBRICATION TABLE**.

To aid starting, the selection of crankcase lubricating oils should be based on the lowest anticipated temperatures until the next scheduled oil change.

For oil change intervals of 100 hours, the following oils are recommended.

Ambient Temperature	Viscosity (Grade SG/SH)
+32°F and Above —	<i>Cub Cadet</i> Engine Oil S.A.E. 10W30
Below +32°F —	<i>Cub Cadet</i> Engine Oil S.A.E. 5W20 or S.A.E. 5W30*

*Synthetic Engine Oil S.A.E. 5W20 or S.A.E. 5W30 is acceptable, up to 40°F. Synthetic oils will provide better starting in extreme cold (below -10°F).

CHECKING THE OIL LEVEL

Regularly checking and maintaining the engine oil level in the crankcase cannot be overemphasized. Close monitoring of the oil level during the first 10 hours of operation is especially important. Referring to Figure 18, check the oil level **BEFORE EACH USE** as follows:

- The engine must be cool so the oil has had time to drain into the sump of the crankcase.
- Clean the area around the oil level dipstick to prevent debris from entering the crankcase.
- Remove the dipstick and wipe it clean. Insert the dipstick into the tube and press all the way down.
- Remove the dipstick and check the oil level.
- Always keep the oil level at or near the "F" mark on the dipstick. If the oil is low, add oil of the proper type up to the "F" mark. Always check the oil level with the dipstick before adding more oil.

- Never operate the engine with the oil level below the "L" mark or above the "F" mark on the dipstick.



Check the oil level only while the engine is stopped and the tractor is level.



The oil level should be checked every hour during the first 5 hours of operation and prior to every use thereafter.

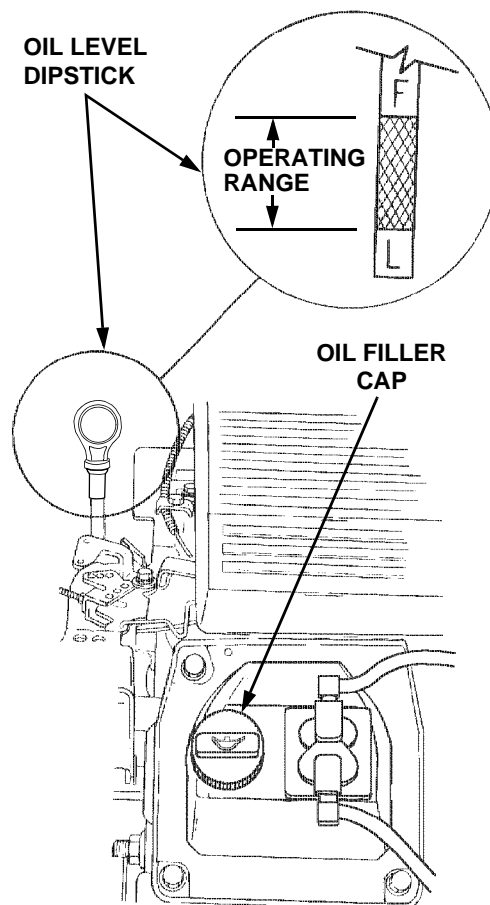

Figure 18

ADDING OIL



CAUTION

Never overfill the engine crankcase. The engine may overheat and/or damage may result if the crankcase is below the "LOW" mark or over the "FULL" mark on the dipstick.

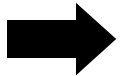

NOTE

For best results, fill to the "FULL" mark on the dipstick as opposed to adding a given quantity of oil. Always check the level on the dipstick before adding more oil.

Refer to the **LUBRICATION TABLE** for information regarding the proper type of oil to add to the crankcase.

1. Place the tractor on a level surface and engage the brake pedal lock. Stop the tractor engine and remove the ignition key.
2. Clean the area around the oil level dipstick, dipstick tube, and the oil filler cap to prevent debris from entering the crankcase.
3. Remove the oil filler cap from the left valve cover and **SLOWLY** pour in oil. Fill the crankcase until the oil level reaches the "FULL" mark on the dipstick (Refer to Figure 18).
4. Reinstall the oil filler cap by screwing it securely into the valve cover.



CAUTION

The oil filler cap **MUST BE TIGHTENED SECURELY INTO THE VALVE COVER AT ALL TIMES WHEN THE ENGINE IS OPERATING**. Severe engine damage could result from failure to do so.

DRAINING OIL AND REPLACING OIL FILTER



NOTE

The engine oil should be changed after the first 5 hours of operation. Then oil should be changed after every 100 hours of operation.



WARNING

If the tractor has recently been operated, the engine and surrounding areas may be hot. Use caution not to burn yourself when removing the side panels, draining the oil from the crankcase, and changing the oil filter.



NOTE

The oil filter should be changed at every oil change interval. The filters can be obtained through your *Cub Cadet* dealer under part number KH-12-050-08.

Refer to the **MAINTENANCE CHART** and the **LUBRICATION TABLE** for information regarding the frequency of required oil changes and the quantity and type of oil needed.

The oil filter is located behind the left side panel and is mounted on the engine (See Figure 19).

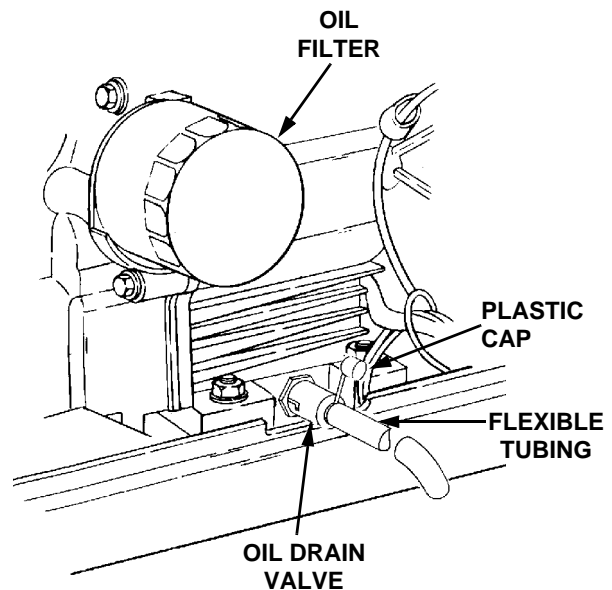

Figure 19

Run the engine for a few minutes to allow the oil in the crankcase to warm up. Warm oil will flow more freely and carry away more of the engine sediment which may have settled at the bottom of the crankcase. Use care to avoid burns from hot oil.

While the engine oil is warm, proceed as follows:

NOTE

A 12 inch length of flexible tubing is supplied in the owner's manual package and should be used to drain the engine oil.

1. Place the tractor on a level surface and engage the brake pedal lock. Stop the tractor engine and remove the ignition key.
2. Clean around the base of the oil filter, oil level dipstick, dipstick tube, and the oil filler cap to prevent debris from entering the crankcase.
3. Unseat the plastic dust cap from the engine oil drain valve. To prevent loss of the cap, do not remove the cap's retaining ring from the drain valve (Refer to Figure 19). Remove the dipstick and oil fill cap.
4. Attach the flexible tubing (supplied in owner's manual package) to the drain valve. Place an appropriate container below the open end of the tubing to collect the old oil.
5. To open the drain valve, push it slightly inward and turn it counterclockwise until it stops, then pull it outward.
6. Remove the filter by turning it counterclockwise using an automotive type filter wrench to loosen.
7. Allow the old oil to completely drain from the engine crankcase into the container below. To close the drain valve, push it inward, turn clockwise until it stops and then release it.
8. Remove the flexible tubing from the drain valve. Clean the tubing and store in a safe place for future use.
9. Clean the drain valve and push the plastic dust cap onto the valve.
10. To assure a continuous flow of oil to all critical lubrication points within the engine, pour some new oil into the treaded center hole of the filter and allow time for the oil to be absorbed into the filter material.
11. Apply a light coating of clean oil on the gasket of the new oil filter. Thread the filter on by hand until the gasket contacts the oil filter adapter, then tighten the filter an additional 1/2 turn.

Refer to **FILLING THE CRANKCASE** and to the **LUBRICATION TABLE** and refill the crankcase with the quantity and type of oil specified.

FILLING THE CRANKCASE

CAUTION

Never overfill the engine crankcase. The engine may overheat and/or damage may result if the crankcase is below the "LOW" mark or over the "FULL" mark on the dipstick.

NOTE

For best results, fill to the "FULL" mark on the dipstick as opposed to adding a given quantity of oil. Always check the level on the dipstick before adding more oil.

Refer to the **LUBRICATION TABLE** for information regarding the oil capacity and the proper type of oil to pour into the crankcase.

1. Place the tractor on a level surface and engage the brake pedal lock. Stop the tractor engine and remove the ignition key.
2. Clean around the oil level dipstick, dipstick tube, and the oil filler cap to prevent debris from entering the crankcase.
3. Remove the oil filler cap from the left valve cover and SLOWLY pour in oil. The oil capacity is approximately 4 pints. Fill the crankcase until the oil level reaches the "FULL" mark on the dipstick (Refer to Figure 18).
4. Reinstall the oil filler cap by screwing it securely into the valve cover.

NOTE

The oil filler cap **MUST BE TIGHTENED SECURELY INTO THE VALVE COVER AT ALL TIMES WHEN THE ENGINE IS OPERATING**. Severe engine damage could result from failure to do so.

5. Start the tractor engine and allow it to run for 30 seconds, then stop the engine and remove the ignition key.
6. Check the oil level and add oil if necessary. **DO NOT OVERFILL THE ENGINE CRANKCASE.**
7. Check the oil filter and drain valve for leaks.

CHECKING TRANSMISSION OIL LEVEL

NOTE

Check the oil level only while the engine is stopped and the tractor is level.

Check the oil level of the transmission case before each use to see that it is filled to the correct level. Before checking the transmission oil level, clean the area around the oil fill plug/dipstick to prevent debris from entering the transmission case. Always keep the oil level between the “FULL” and the “ADD” marks on the dipstick (See Figure 20). When checking the oil level, the dipstick must be withdrawn and wiped clean, then inserted all the way before being withdrawn for a true reading.

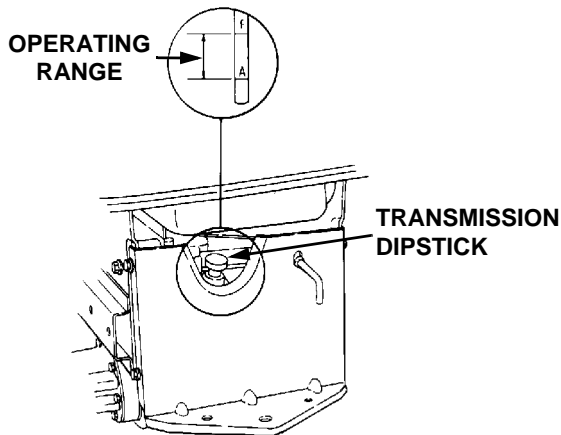

Figure 20

ADDING TRANSMISSION OIL

CAUTION

Never overfill the transmission case. Damage may result if the oil level in the transmission case is below the “ADD” mark or over the “FULL” mark of the dipstick.

NOTE

For best results, fill to the “FULL” mark on the dipstick as opposed to adding a given quantity of oil. Always check the level on the dipstick before adding more oil.

Refer to the **LUBRICATION TABLE** for information regarding the proper type of oil to add to the transmission case.

1. Place the tractor on a level surface and engage the brake pedal lock. Stop the tractor engine and remove the ignition key.
2. Clean the area around the oil fill plug/dipstick to prevent debris from entering the transmission case.
3. Remove the oil fill plug/dipstick from the oil fill port and SLOWLY pour oil into the oil fill port. Fill the transmission case until the oil level reaches the “FULL” mark on the dipstick (Refer to Figure 20).
4. Reinstall the oil fill plug/dipstick securely into the oil fill port.

CAUTION

The oil fill plug/dipstick **MUST BE INSTALLED SECURELY INTO THE FILL PORT AT ALL TIMES WHEN THE ENGINE IS OPERATING.**

HYDROSTATIC DRIVE OIL FILTER

CAUTION

Never overfill the transmission case. Damage may result if the oil level in the transmission case is below the “ADD” mark or over the “FULL” mark of the dipstick.

NOTE

For best results, fill to the “FULL” mark on the dipstick as opposed to adding a given quantity of oil. Always check the level on the dipstick before adding more oil.

Refer to the **MAINTENANCE CHART** for information regarding the frequency of the hydrostatic transmission oil filter replacement. The filter can be obtained through your *Cub Cadet* dealer under the part number 923-3014.

Refer to the **LUBRICATION TABLE** for information regarding the oil capacity and the proper type of oil to pour into the transmission case.

1. Place the tractor on a level surface and engage the brake pedal lock. Stop the tractor engine and remove the ignition key.

- Clean the area around the transmission drain plug to prevent debris from entering the transmission case. Remove the drain plug and allow the transmission oil to drain into a clean container having a capacity of more than 6 quarts. Reinstall the drain plug (Refer to Figure 21).



CAUTION

If the transmission oil is to be re-used, cover the container holding the drained oil to prevent contamination. Contaminated transmission oil can damage the hydro transmission.

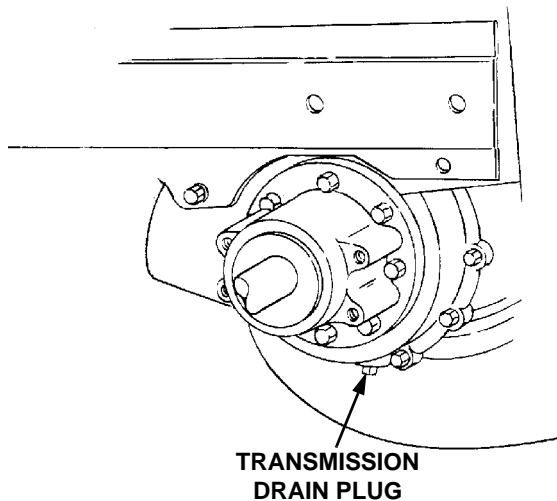

Figure 21

- Clean around the base of the transmission oil filter and remove the filter by turning it counterclockwise (Refer to Figure 22).
- Apply a light coating of clean transmission oil to the gasket of the new filter. Install the filter by turning it clockwise, by hand, until the gasket contacts the filter base on the transmission housing; then tighten the filter an additional 1/2 turn.
- Clean the area around the transmission oil fill plug/dipstick to prevent debris from entering the transmission case.
- Remove the oil fill plug/dipstick from the oil fill port and SLOWLY pour oil into the oil fill port. Fill the transmission case until the oil level reaches the "FULL" mark on the dipstick (Refer to Figure 20).

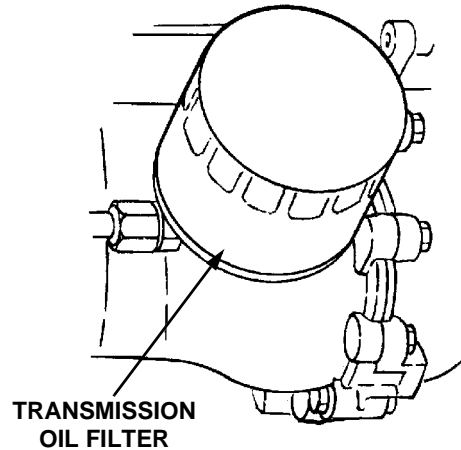

Figure 22

- Reinstall the oil fill plug/dipstick securely into the oil fill port.
- Start the engine and allow it to run for a few minutes. Shut the engine off, then check for leaks and re-check the oil level in the transmission case.



CAUTION

The oil fill plug/dipstick **MUST BE INSTALLED SECURELY INTO THE FILL PORT AT ALL TIMES WHEN THE ENGINE IS OPERATING.**

AIR CLEANER

Check the air cleaner daily or before starting the engine. Check for loose or damaged components and check the condition of the filter element. Remove any buildup of dirt and debris in the air cleaner housing.

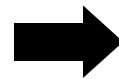

NOTE

Operating the engine with loose or damaged air cleaner components will allow unfiltered air into the carburetor; causing extensive wear and eventual failure of the engine.

Servicing the Precleaner

Wash and re-oil the foam pre-cleaner at 1 month intervals or after every 10 hours of operation (more often under extremely dusty or dirty conditions), whichever occurs first.

- Unfasten the air cleaner cover retaining knob and remove the air cleaner cover (See Figure 23).

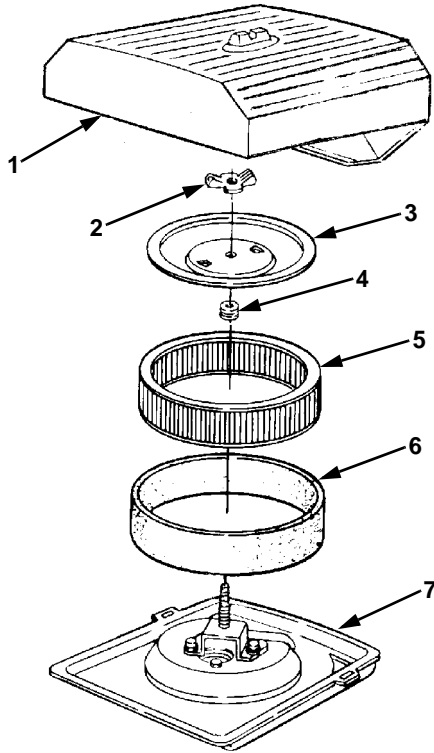

- | | |
|----------------------|---------------------|
| 1. Air Cleaner Cover | 5. Paper Element |
| 2. Wing Nut | 6. Foam Precleaner |
| 3. Element Cover | 7. Air Cleaner Base |
| 4. Rubber Grommet | |

Figure 23. Air Cleaner Assembly

2. Remove the foam precleaner by sliding it up off the paper element (See Figure 23).
3. Wash the precleaner in warm water with detergent. Rinse the precleaner thoroughly until all traces of the detergent are eliminated. Squeeze out (do not wring) excess water in a dry cloth. Allow the precleaner to air dry.
4. Saturate the foam precleaner with new engine oil. Squeeze out all excess oil.
5. Reinstall the foam precleaner over the paper element.
6. Reinstall the air cleaner cover and secure with the retaining knob.

Servicing the Paper Element

Inspect the paper element before each use. Every 100 hours of operation (more often under extremely dusty or dirty conditions) replace the element.

1. Unfasten the air cleaner cover retaining knob and remove the air cleaner cover (See Figure 23).
2. Remove the foam precleaner by sliding it up off the paper element (See Figure 23).
3. Remove the wing nut and element cover plate, then lift out the paper air filter element.
4. Do not wash the paper element or use pressurized air, as this will damage the element. Replace a dirty, bent or damaged element. Handle new elements carefully; do not use if the sealing surfaces are bent or damaged.
5. When servicing the air cleaner, check the air cleaner base. Make sure it is secured and not bent or damaged. Also check the element cover for damage or improper fit. Replace all damaged air cleaner components.
6. Inspect the rubber grommet (See Figure 23) for deterioration, cracks, and for a snug fit on the air cleaner stud. Replace if damaged or worn.
7. Reinstall the paper element, foam precleaner, element cover, wing nut and air cleaner cover. Make certain the cover retaining knob is tightened securely.

Properly cleaned and installed air cleaner elements significantly contribute to prolonging engine life.

CLEANING ENGINE

This tractor has an air-cooled engine. Air must be able to circulate freely through the flywheel screen, blower housing, and cooling shrouds, and over the cooling fins of the cylinder head and cylinder block. Regularly check these areas for accumulated dirt and debris to prevent engine overheating and possibly causing extensive engine damage. Every 100 hours of operation, remove the blower housing and cooling shrouds to clean the cooling surfaces of the engine. Make sure the cooling shrouds are reinstalled.

Regularly clean the outside and inside of the side panel screens, the dash intake screen and the grille to ensure adequate air flow for cooling the engine.

NOTE

This machine is designed to cool properly with the side panels in place. Operating without the panels could cause premature accumulation of dirt and debris on the engine, resulting in inadequate cooling.

SPARK PLUG



WARNING

To avoid possible injury, be sure the engine is off and has cooled before making any adjustments or repairs.



NOTE

Remove all dirt from around the spark plug before removing.

To remove the spark plugs, always use a spark plug wrench. Check the gap after every 100 hours of operation.

Replace a defective plug with a new plug. Set the spark plug gap at .030 inch (See Figure 24). Tighten the plug to 18-22 ft-lbs. See your authorized dealer for the correct replacement plug.

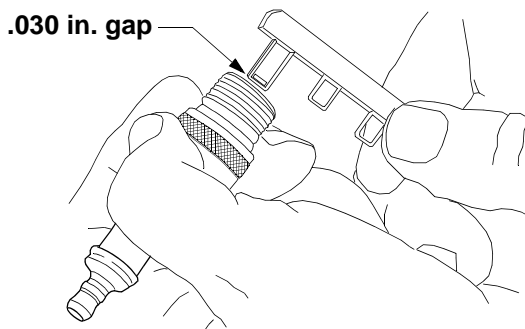

Figure 24

FUEL FILTER



WARNING

Do not replace the fuel filter when engine is hot.

The engine is equipped with an inline fuel filter. Visually inspect the filter periodically for a build-up of residue inside the filter body, and for a dirty element which can be indicated by discoloration. Replace the fuel filter when dirty.

HEADLIGHTS

Refer to **SPECIFICATIONS** when replacement of head lamp bulbs is necessary.



WARNING

Allow the engine and surrounding surfaces to cool before changing the head lamp bulbs.

Replace headlight bulbs as follows: (See Figure 25)

1. Unplug the wire harness leads from the headlight socket terminals. *Note which wire connects to each terminal before disconnecting.*
2. Rotate the socket assembly as follows to remove from the reflector housing:
 - Left headlight — approximately 1/4 turn counterclockwise.
 - Right headlight — approximately 1/4 turn clockwise.
3. Push the bulb inward and turn counterclockwise to remove from the socket.

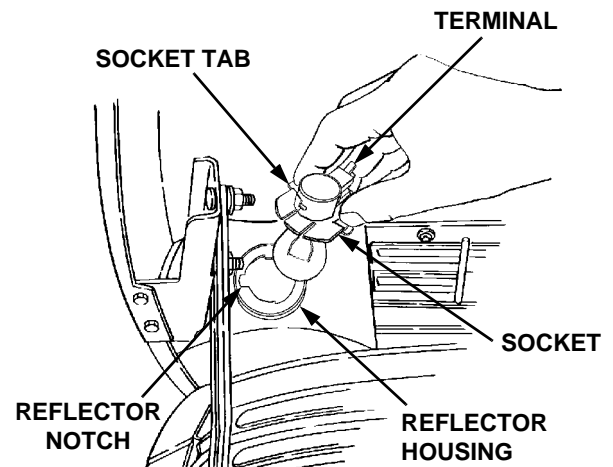

Figure 25

4. Align a locking post of the bulb base with the notch in the socket, then push the bulb inward and turn clockwise to lock
5. With the terminals pointing upward, align the tab of the socket with the notch of the reflector. Push the socket inward and turn as follows to lock:
 - Left headlight — approximately 1/4 turn clockwise.
 - Right headlight — approximately 1/4 turn counterclockwise.
6. Connect the wire harness leads to the appropriate socket terminals.

FUSES

Always use the same capacity fuse for replacement. Refer to **SPECIFICATIONS**. If the electrical system does not function, check the fuses.

To replace a fuse, pull the old fuse from the fuse holder and install the new fuse.

GENERAL BATTERY INFORMATION



WARNING

- a. Battery posts, terminals and related accessories contain lead and lead compounds. **Wash Hands after handling.**
- b. Should battery acid accidentally splatter into the eyes or onto the skin, rinse the affected area immediately with clean cold water. If there is any further discomfort, seek prompt medical attention.
- c. If acid spills on clothing, first dilute it with clean water, then neutralize with a solution of ammonia/water or baking soda/water.
- d. NEVER connect (or disconnect) battery charger clips to the battery while the charger is turned on, as it can cause sparks.
- e. Keep all sources of ignition (cigarettes, matches, lighters) away from the battery. The hydrogen gas generated during charging can be combustible.
- f. As a further precaution, only charge the battery in a well ventilated area.

ALWAYS SHIELD EYES AND PROTECT SKIN AND CLOTHING WHEN WORKING NEAR BATTERIES.



DANGER

BATTERIES CONTAIN SULFURIC ACID AND MAY EMIT EXPLOSIVE GASES. USE EXTREME CAUTION WHEN HANDLING BATTERIES.

KEEP BATTERIES OUT OF THE REACH OF CHILDREN.

MAINTENANCE OF BATTERY

The tractor is shipped with a wet battery — the battery acid has already been added and the battery sealed. Although the battery is maintenance free, the following care should be taken when handling the battery and to assure its proper life cycle.

1. Spray the terminals and exposed wire with a battery terminal sealer, or coat the terminals with a thin coat of grease or petroleum jelly, to protect against corrosion.
2. Always keep the battery cables and terminals clean and free of corrosion.
3. Always keep the terminal covers in place over the battery terminals.
4. Avoid tipping. Even a sealed battery will leak electrolyte when tipped.

STORAGE OF THE BATTERY

1. When storing the tractor for extended periods, disconnect the negative battery cable. It is not necessary to remove the battery.
2. All batteries discharge during storage. Keep the exterior of the battery clean, especially the top. A dirty battery will discharge more rapidly.
3. The battery must be stored with a full charge. A discharged battery can freeze sooner than a charged battery. A fully charged battery will store longer in cold temperatures than hot.
4. Recharge the battery before returning to service. Although the tractor may start, the engine charging system may not fully recharge the battery.

COMMON CAUSES FOR BATTERY FAILURE

1. Overcharging
2. Undercharging
3. Loose and/or corroded connections
4. Excessive loads
5. Freezing of electrolyte

* **These causes do not constitute warranty in the event of a battery failure.**

BATTERY REMOVAL OR INSTALLATION



WARNING

Battery posts, terminals and related accessories contain lead and lead compounds. **Wash Hands after handling.**

When removing the battery, disconnect the battery cables in the following order to avoid arcing and the resulting sparks:

Battery Removal:

1. Disconnect the Negative cable.
2. Disconnect the Positive cable.

Battery Installation:

1. Connect the Positive cable.
2. Connect the Negative cable.

To replace the battery, proceed as follows:

1. Remove the negative cable from the negative terminal of the battery, then remove the positive cable from the positive terminal.
2. Remove the wing nut securing the LH mounting rod to the mounting tab on the left side of the bulkhead (See Figure 26). Pull the rod downward from the bulkhead tab.

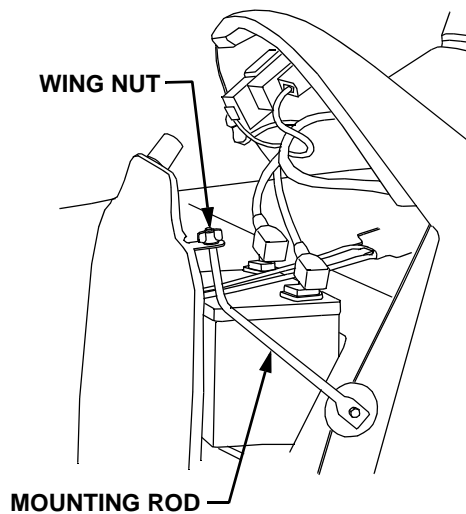

Figure 26

3. Rotate the mounting rod fully upward toward the dash panel to provide clearance for battery removal (Refer to Figure 27).

4. Pull downward on the bottom of the battery holddown strap to release it from the tab beneath the battery tray.
5. Loosen the hose clamp and pull the drain tube from the battery.
6. Lift the battery upward and remove from the left side of the tractor.

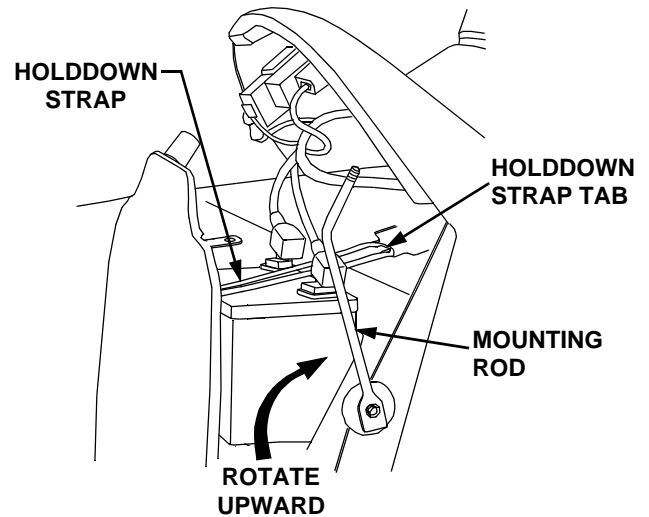

Figure 27

7. Install the new battery from the left side of the tractor and lower into the battery tray.
8. Install the drain tube onto the battery and secure with the hose clamp.
9. After making sure the holddown is securely looped around the tab on top of the pedestal, stretch the battery holddown strap downward across the front of the battery and loop around the tab below the battery tray.
10. Rotate the mounting rod downward and insert through the bottom of the hole in the bulkhead mounting tab (Refer to Figure 26).
11. Install the wing nut onto the mounting rod, but do not tighten until after the side panels are installed.
12. Connect the positive cable to the positive terminal of the battery, then connect the negative cable to the negative terminal.

CHARGING THE BATTERY

Test and, if necessary, recharge the battery after the tractor has been stored for a period of time.

- A voltmeter or load tester should read 12.6 volts (DC) or higher across the battery terminals.
- Charge the battery with a 12-volt battery charger at a **MAXIMUM** rate of 10 amps.

Voltmeter Reading	State of Charge	Charging Time
12.7	100%	Full Charge
12.4	75%	90 Min.
12.2	50%	180 Min.
12.0	25%	280 Min.

JUMP STARTING



WARNING

Failure to use this jump starting procedure could cause sparking, which could result in an explosion of either battery.

1. Attach the first jumper cable from the positive terminal of the good battery to the positive terminal of the dead battery.
2. Attach the second jumper cable from the negative terminal of the good battery to the **FRAME OF THE UNIT WITH THE DEAD BATTERY.**

TIRES

Keep the pneumatic tires properly inflated. Over-inflation will cause operator discomfort. Under-inflation will cause short tire life.

Improperly inflated tires will also affect the leveling of the mower deck and quality of cut.

Inflate the front and rear tires as shown in the following table:

Tire Size Pounds per Square Inch

Front Tires	
16 x 6.5–8	14
Rear Tires	
23 x 9.5–12	10

Always ensure that the tire valve caps are in place and tightened securely to prevent loss of air and to protect the valve core and stem.

Do not overload the tractor tires by mounting equipment on the tractor which exceeds the load capacity of the size of the tires on the tractor.

MOUNTING TIRES ON THE RIM



WARNING

Do not mount a tire unless you have the proper equipment. Do not inflate the tire above the recommended pressure. Do not stand over the tire assembly when inflating. Accidental over inflation could cause an explosive separation of the tire and rim, which could result in serious injury or death.

After mounting a new or old tire on the rim, inflate it to 20 pounds (maximum) pressure to seat the tire bead on the rim flange. Then deflate the tire to the correct operating pressure.



NOTE

After the first 10 hours of operation, check and retorque the rear wheel lug nuts (both sides) to 35 ft-lbs to make sure they are seated in the rim and are properly tightened.

SECTION V. MOWER DECK

This section contains adjustment, removal, installation, and maintenance information for the 44-inch mower deck. Instructions for installation and removal of the optional mulching plug are located at the end of this section.

A. INSTALLING LIFT ASSIST SPRING

NOTE

The following step 1 applies **only** if the lift assist spring has been factory installed. If the spring was not installed, proceed to step 2.

1. **If RH Lift Assist Spring Is Factory Installed.** From beneath the right rear fender, push the lift assist rod down and outward to release from the frame. Disengage the hook of the lift assist spring from the pigtail hook (See Figure 28).

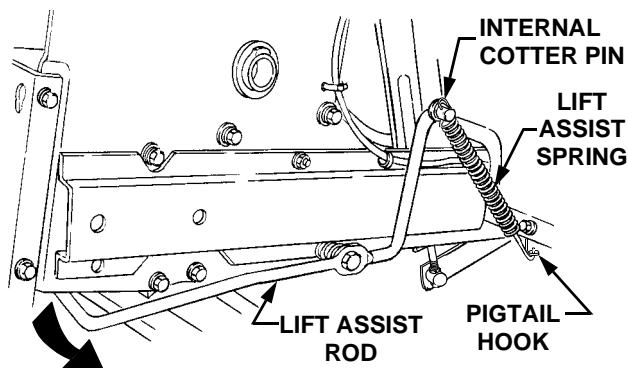

Figure 28

2. **If RH Lift Assist Spring Is Not Installed.**
 - From underneath the fender on the right/rear side of the tractor frame, remove the internal cotter pin from the forward end of the rod. Refer to Figure 28.
 - Slide the larger hook of the lift assist spring onto the forward end of the rod, and reinstall the internal cotter pin to capture the spring hook between the flange of the rod and the pin. Refer to Figure 28.
3. Install the lower hook of the lift assist spring into the hole in the right rear deck bracket (See Figure 29).

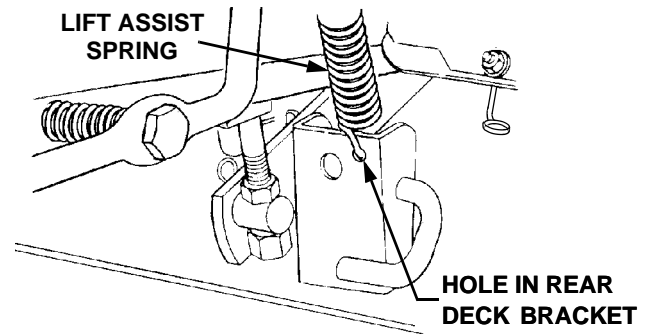

Figure 29

4. Tension the spring by pushing downward and then inward on the rear of the lift assist rod, so that the flange at the rearward end of the rod is inside the tractor frame (See Figure 30).

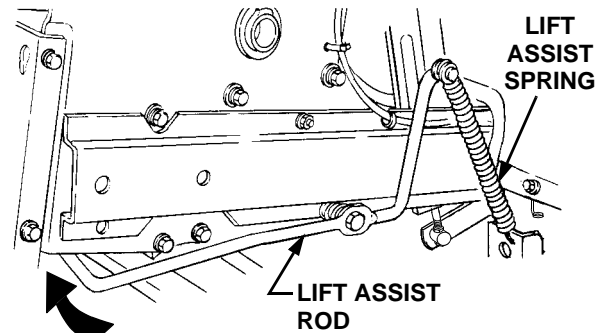

Figure 30

B. DECK LEVELING ADJUSTMENTS

In order to achieve even cutting, the mower deck must be properly leveled. This leveling procedure will result in the left and right blades having corresponding front cutting-edge-to-ground measurements within 1/16 inch of each other. Also, the blades will each have a 1/8 to 1/4 inch downward tilt toward the front of the tractor. To level the mower deck, proceed as follows:



WARNING

Before making any adjustments, place the PTO switch in the "OFF" position, engage the brake pedal lock, turn the ignition key to the "OFF" position, and remove the key from the switch. Disconnect the spark plug wires for additional safety. When handling the mower deck, be careful not to cut yourself on the sharp blades.

NOTE

Check the tires for proper inflation before making a leveling adjustment. To level the deck, the tractor and deck **MUST** be placed on a hard, level surface during adjustment.

SIDE-TO-SIDE LEVELING ADJUSTMENT

1. Position the tractor and mower deck on a hard, level surface.
2. The mower deck front and rear gauge wheels should be installed in their uppermost position in the deck brackets to prevent contact with the hard, level surface below. Refer to **GAUGE WHEEL ADJUSTMENT**.
3. Raise the tractor implement lift handle to its highest setting.
4. Carefully rotate the outer cutting blades so that they are positioned perpendicular to the tractor frame (Refer to Figure 31).

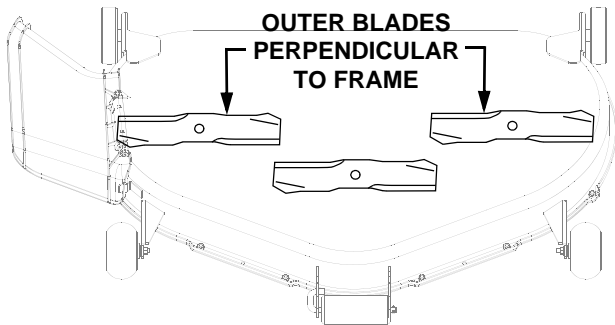

Figure 31

5. Referring to Figure 32, measure and record the distance from the hard, level surface to the outermost cutting edge of the right blade. Repeat this step for the left blade. If the two blade heights are not within 1/16 inch, proceed to steps 6, 7 and 8. If the two blade heights are within 1/16 inch, proceed to **FRONT TO BACK LEVELING ADJUSTMENT**.

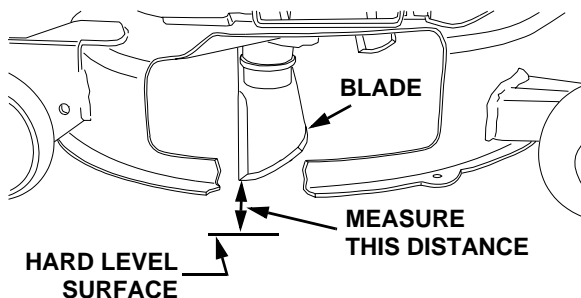

Figure 32

6. Lower the deck onto the hard, level surface.
7. Side-to-side leveling is obtained utilizing the adjustment ferrule and right hand hanger bracket (Refer to Figure 33).

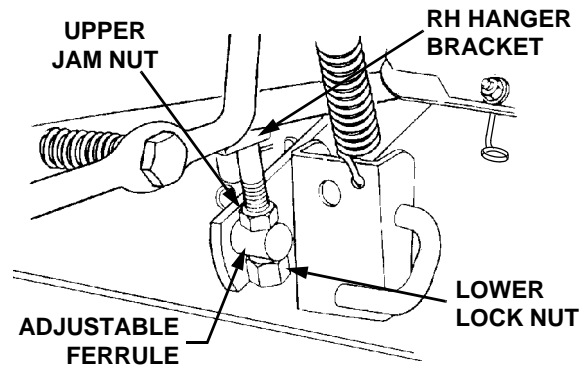

Figure 33

8. Loosen the upper jam nut on the hanger bracket and turn away from the adjustment ferrule. Turn the lower lock nut upward (tighten) on the threads of the hanger bracket to raise the right side of the mower deck. Turn the lock nut down (loosen) on the threads to lower the right side of the mower deck (Refer to Figure 33).
9. Raise the lift handle to the highest position and recheck the blade measurements described in step 5. If the blade measurements are not within 1/16 inch, repeat steps 6, 7 and 8.
10. Tighten the upper jam nut against the adjustment ferrule after side-to-side leveling is completed.

FRONT TO BACK LEVELING ADJUSTMENT

1. Raise the deck to its highest position.
2. Position the mower blades so the ends of each blade point to the front and the rear of the tractor (Refer to Figure 34).

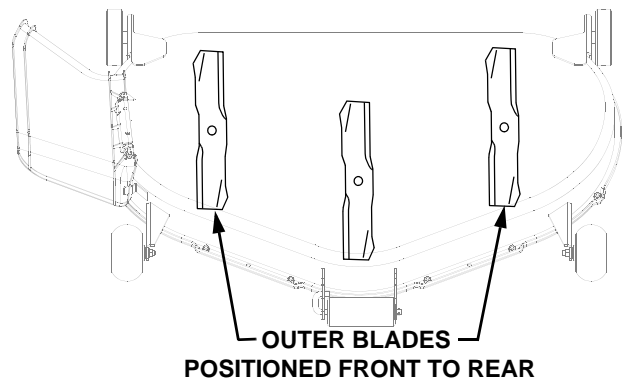

Figure 34

- Initially adjust the front lift rod to allow approximately 5/8 inch of thread to protrude beyond both lock nuts of the front lift rod/bracket assembly (Refer to Figure 35).

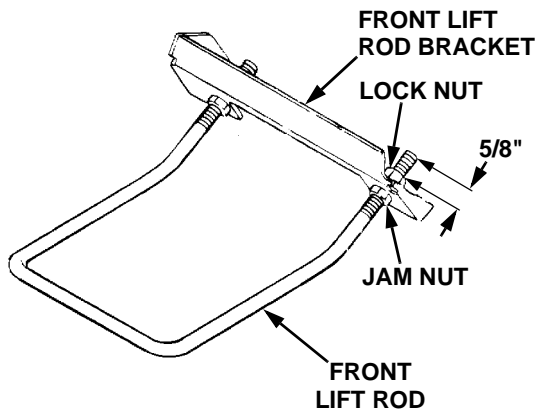

Figure 35

- Refer to Figure 36. Measure and record the distance from the front cutting edge to the ground (measurement A), and from the rear cutting edge to the ground (measurement B), for each of the blades. The front edge of each blade (measurement A) should be lower than its back edge (measurement B) by 1/8 to 1/4 inch.

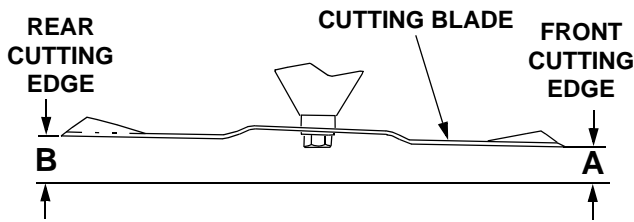

Figure 36

- Lower the deck onto the hard, level surface.
- To adjust the downward tilt of the blades, adjustment of the front lift rod is required. Refer to Figure 35 and proceed as follows:
- Loosen the rear jam nuts on the front lift rod. From the front of the tractor, **evenly** turn the front lock nuts clockwise to raise the front of the mower deck, or counterclockwise to lower the front of the mower deck.
- Raise the deck to the highest position. Recheck the blade measurements described in step 4. If the resultant measurements are not correct, repeat steps 5, 6 and 7 until the proper measurements are obtained.

NOTE

The front lift rod must be against the front of both slots in the deck front roller bracket. If one side of the rod is not against the front of the slot after attaining the correct front pitch to the deck, tighten the front lock nut on that side until the rod just contacts the front of the slot.

- Tighten the rear jam nuts after adjustment is completed.
- Connect the spark plug wires if previously disconnected.

GAUGE WHEEL ADJUSTMENT



WARNING

Before making any adjustments, place the PTO switch in the "OFF" position, engage the brake pedal lock, turn the ignition key to the "OFF" position, and remove the key from the switch. Disconnect the spark plug wires for additional safety. When handling the mower deck, be careful not to cut yourself on the sharp blades.

NOTE

Gauge wheel adjustment should be performed only **AFTER** the mower deck has been properly leveled.

NOTE

Gauge wheels are intended to prevent scalping of the lawn, and are not meant to be used to set the cutting height. Do not run the deck on the gauge wheels.

To adjust the height of the gauge wheels, place the tractor on a firm and level surface. Refer to Figure 37, and proceed as follows:

- Place the tractor implement lift handle in the normally desired mowing height setting, then check the gauge wheels for contact or excessive clearance with the surface below.
- If the wheels contact the surface adjust as follows:
 - Raise the implement lift handle to its highest setting.
 - Remove the rear gauge wheels by removing the lock nuts, shoulder screws, and flat

washers. Remove the lock nuts, shoulder screws, and bell washers fastening the front ball wheels to the deck gauge wheel brackets.

- c. Again place the tractor implement lift handle in the normally desired mowing height setting.

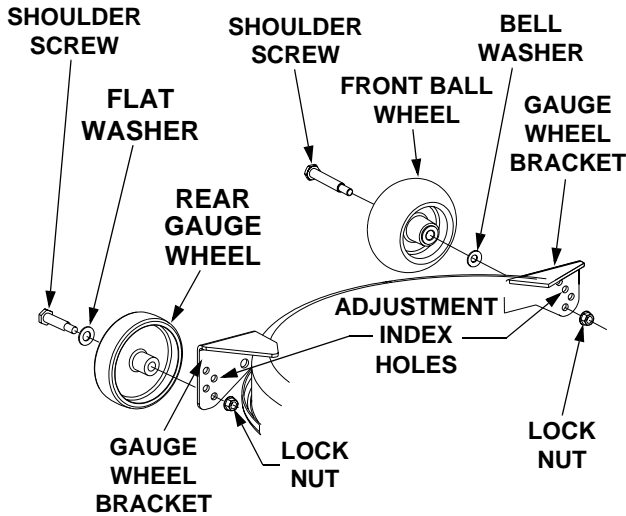

Figure 37

- d. Insert the shoulder screw and flat washer with the rear gauge wheel into the adjustment index hole that provides approximately 1/2" clearance between the wheel and level surface. Secure with the lock nut.
- e. Note the position of the index hole used; then install the other rear gauge wheel and the front ball wheels into the corresponding index hole of the other gauge wheel brackets.

NOTE

The crowned (rounded) surface of the front bell washers should be against the shoulder of the shoulder screw, between the front ball wheel and deck gauge wheel bracket.

- 3. If the gauge wheels have excessive clearance with the surface below, lower the wheels to the index hole that provides the approximate 1/2" clearance as described above.

NOTE

All gauge wheels should be installed in the same relative adjustment index hole location in each of the gauge wheel brackets.

CUTTING HEIGHT ADJUSTMENT

The mower can be set in multiple positions. *NOTE: If multiple settings are used while mowing, it may be necessary to adjust the gauge wheels for each setting to prevent scalping.*

1. Push, or pull, the tractor implement lift handle to depress the button on top of the lift handle.
2. Raise or lower the lift handle to obtain the desired mower deck cutting height.
3. Release the button when the desired mower position is obtained. *Note the numbered position of the lift lever indicator so that the deck can be returned to this position.*

C. REMOVAL AND INSTALLATION OF DECK ASSEMBLY

REMOVAL OF DECK

WARNING

Before removing the mower deck, place the PTO switch in the "OFF" position, engage the brake pedal lock, turn the ignition key to the "OFF" position and remove the key from the switch. Disconnect the spark plug wires for additional safety.

1. Position the tractor and mower deck on a firm, level surface. Raise the gauge wheels to their highest setting in the gauge wheel brackets (Refer to Figure 37).
2. Raise the deck by moving the implement lift handle to its highest setting. From beneath the right rear fender, release the RH lift assist rod from the tractor frame by pushing down then outward on the rear end of the rod. Allow the lift assist rod to raise upward and disengage the lower hook of the lift assist spring from the hole in the right rear deck bracket (See Figure 38).

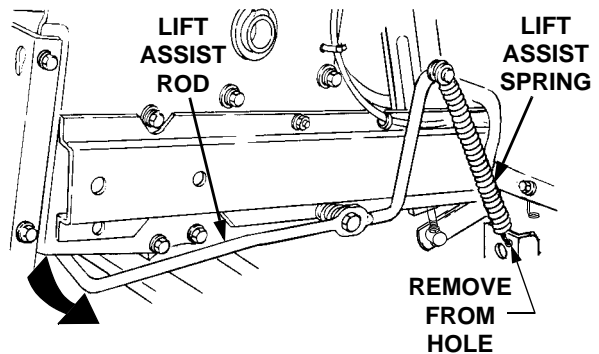

Figure 38

3. While lowering the rear end of the lift assist rod, guide the lower spring hook into the pigtail hook at the lower front of the fender (See Figure 39).
4. Tension the spring by pushing downward and then inward on the rear of the lift assist rod, so that the flange at the rearward end of the rod is inside the tractor frame (See Figure 39).

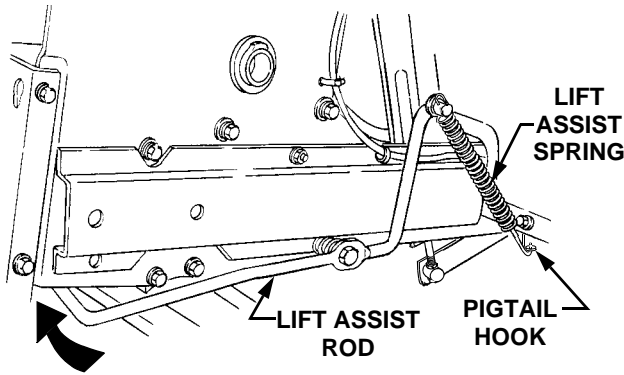

Figure 39



WARNING

When handling the mower deck, be careful not to cut yourself on the sharp blades. The deck idler arm lever is spring loaded. Release it slowly.

5. Lower the tractor implement lift handle to its lowest setting. Disengage the deck idler arm lever from its stop bracket and release the spring tension by rotating the lever out and rearward (Refer to Figure 40).

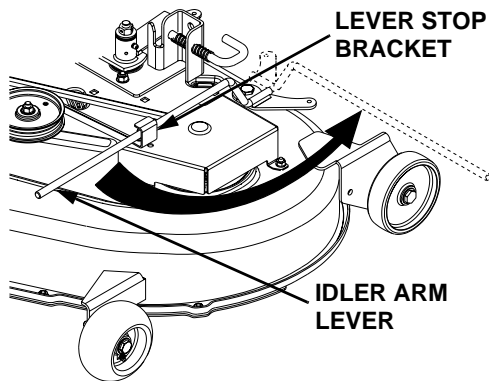

Figure 40

6. Remove the rearward end of the PTO belt from the upper pulley of the deck center double-pulley (See to Figure 41). Engage the deck idler arm lever back into its stop bracket (Refer to Figure 40).

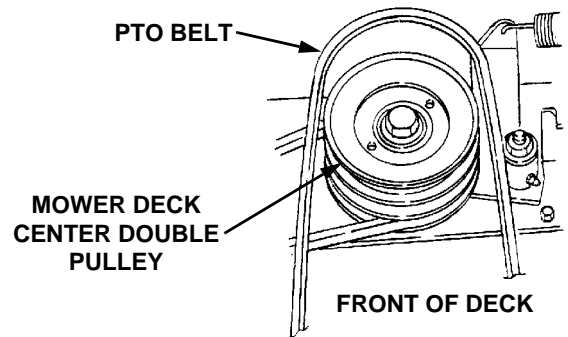

Figure 41



WARNING

The exhaust system is HOT. To avoid personal injury, allow the engine and exhaust system to cool before proceeding with the following PTO belt removal instructions.

7. Open the tractor hood and remove the forward end of the PTO belt from the PTO clutch pulley on the front of the engine (See Figure 42).

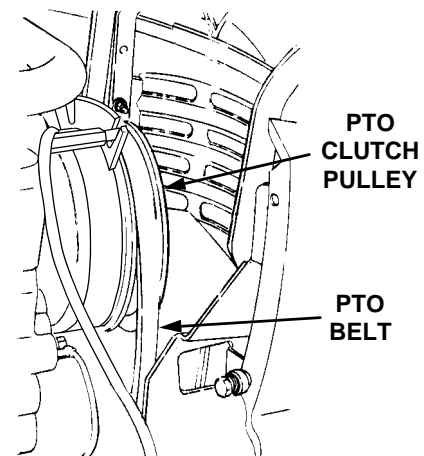

Figure 42

8. Pass the PTO belt downward, inside the tractor frame, until the belt is below the two tractor front lower pulleys and pull the belt clear of the tractor (Refer to Figure 43).

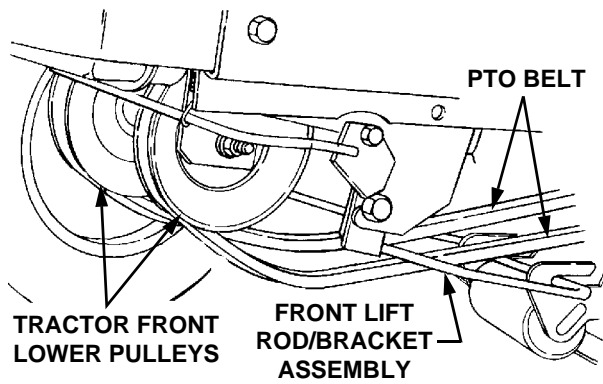

Figure 43

9. Pull the deck support pins outward, turn downward and release so both spring-loaded pins are held in the disengaged position against the outer surface of the deck brackets (Refer to Figure 44).

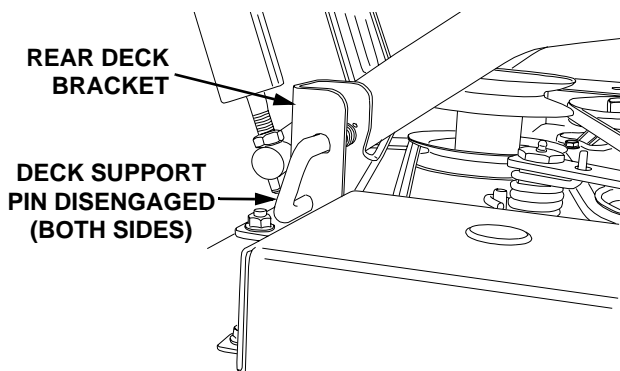

Figure 44

10. Raise the implement lift handle to its highest setting. Slide the mower deck forward, so the front lift rod rests to the rear of, and free of, the front roller bracket slots of the deck (Refer to Figure 45-A).

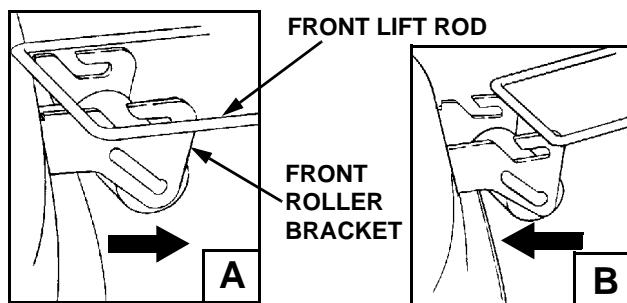

Figure 45

11. Raise the front lift rod upward and slide the mower deck rearward. Lower the front lift rod so it rests on the front roller bracket of the deck, forward of the slots (Refer to Figure 45-B).

12. From the front of the tractor, push downward and hold the tractor quick-attach rod. Pull the front lift rod/bracket assembly forward to release the shoulder bolts on each side of the bracket from the left and right tractor latch receivers. Release the tractor quick-attach rod. Refer to Figure 46

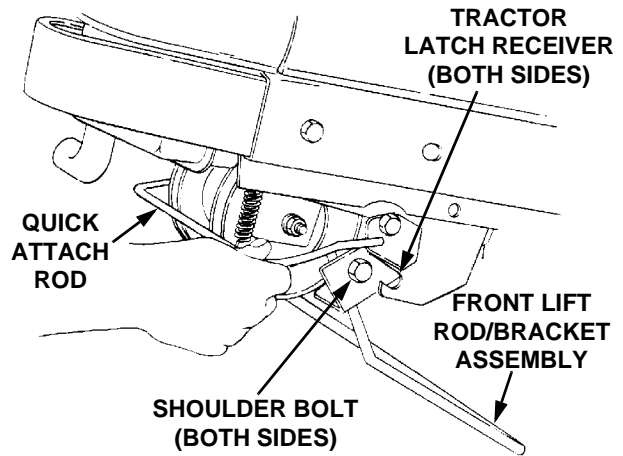

Figure 46



CAUTION

To avoid possible equipment damage, make sure that the tractor implement lift handle is raised to its highest setting before sliding the deck out from under the tractor.

13. With the tractor implement lift handle raised to its highest setting, slide the deck to the right and out from under the tractor (Refer to Figure 47).

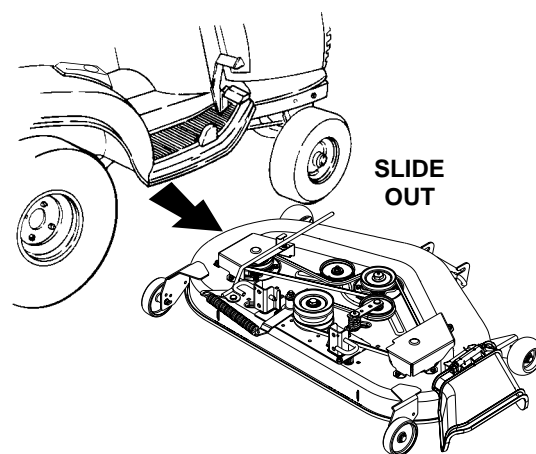

Figure 47

14. Connect the spark plug wires if disconnected.

INSTALLATION OF DECK



WARNING

Before performing the mower deck installation, place the PTO switch in the "OFF" position, engage the brake pedal lock, turn the ignition key to the "OFF" position and remove the key from the switch. Disconnect the spark plug wires for additional safety.



WARNING

When handling the mower deck, be careful not to cut yourself on the sharp blades.

1. Position the tractor and mower deck on a firm, level surface. Raise the gauge wheels to their highest setting in the gauge wheel brackets (Refer to Figure 37).



CAUTION

To avoid possible equipment damage, make sure that the tractor implement lift handle is raised to its highest setting before sliding the deck under the tractor.

2. Refer to Figure 48 and position the deck on the right side of the tractor with the front of the deck facing toward the front of the tractor. Raise the tractor implement lift handle to its highest setting and slide the deck under the tractor.

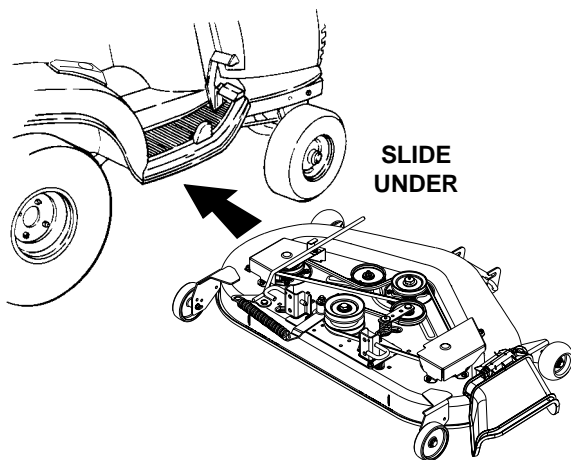

Figure 48

3. Make sure the slot in both rear deck brackets aligns with the implement lift link on each side of the tractor (Refer to Figure 49).

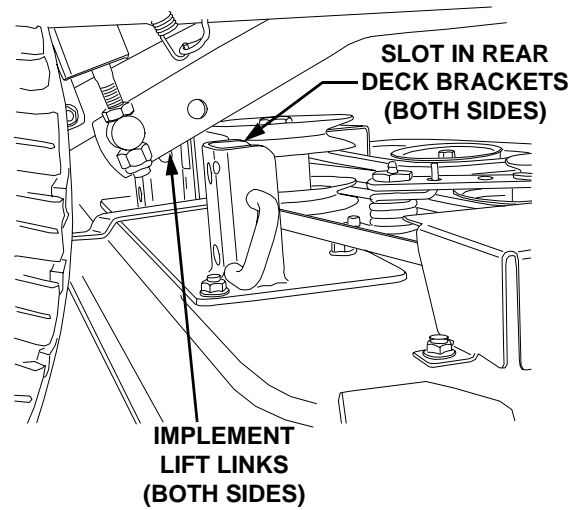

Figure 49

4. Refer to Figure 50 to ensure the correct orientation of the front lift rod/bracket assembly [form (bend) in sides of rod point downward]. From the front of the tractor, push downward and hold the tractor quick-attach rod. Slide the shoulder bolts on each side of the front lift rod/bracket assembly fully into the left and right tractor latch receivers. Release the tractor quick-attach rod to capture the front lift rod/bracket assembly in the tractor latch receivers (Refer to Figure 51).

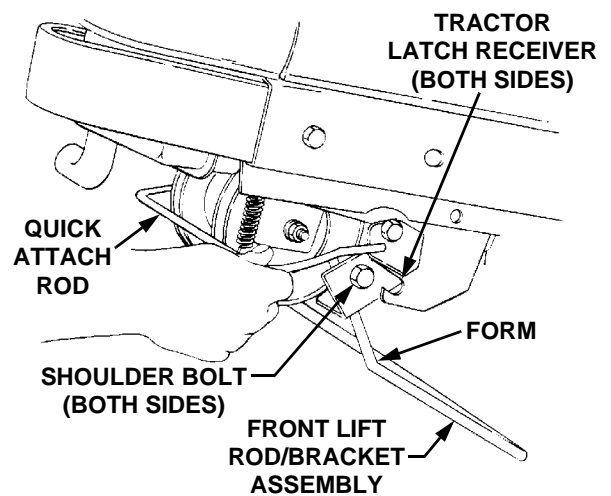

Figure 50

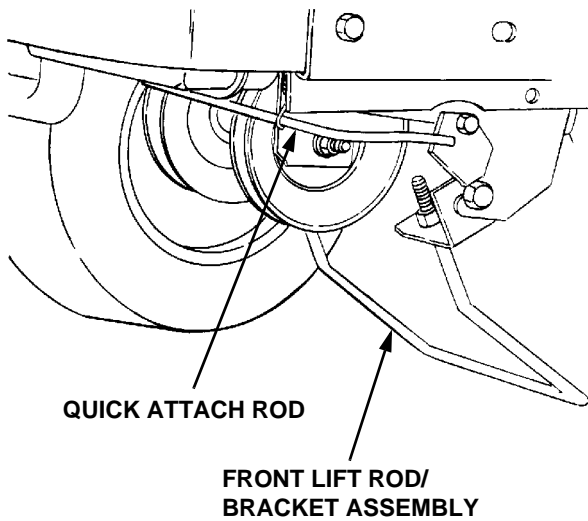

Figure 51

5. While holding the front lift rod up, slide the mower deck forward until the rod aligns with both front roller bracket slots. Lower the lift rod into the front roller bracket slots and slide the deck rearward to engage the lift rod fully forward in the slots of the deck front roller bracket (Refer to Figure 52).

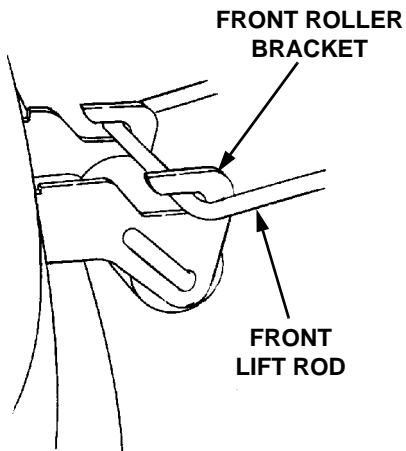

Figure 52

6. If not already done, pull the deck support pins outward, turn downward and release so both spring-loaded pins are held in the disengaged position against the outer surface of the deck brackets (Refer to Figure 53).

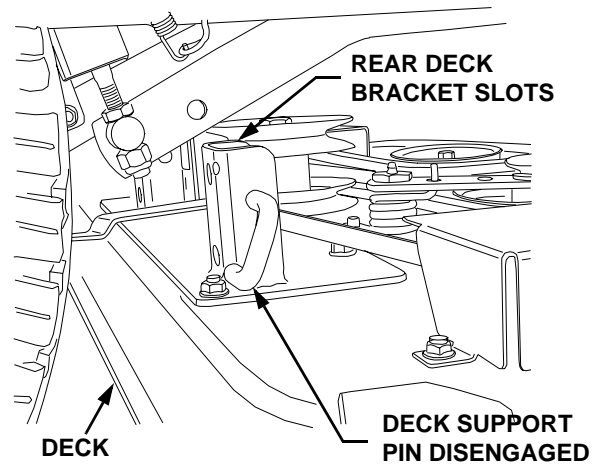

Figure 53

7. Carefully guide the tractor implement lift links (left and right) into the rear deck bracket slots (left and right) as the tractor implement lift handle is lowered to its lowest setting (Refer to Figure 54).
8. Pull both deck support pins outward and rotate rearward to disengage the outer surface of the rear deck brackets. Release the pins, making certain each deck support pin passes through the inner hole of the rear deck bracket. The spring tension will push the pins inward and, if aligned, through the hole in each implement lift link (See Figure 54).

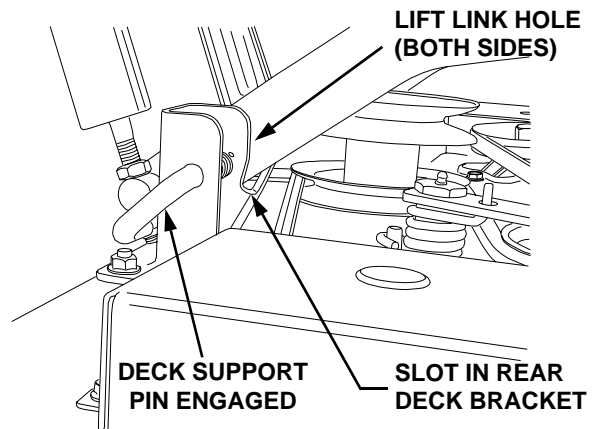

Figure 54

NOTE

It may be necessary to lift each side of the deck and maneuver it slightly to align the support pins with the holes of the lift links. Make certain the support pins are fully extended through the lift links to prevent the mower deck from disengaging the lift links while mowing.

- From beneath the right rear fender, push the lift assist rod down and outward to release from the frame. Disengage the hook of the lift assist spring from the pigtail hook (See Figure 55).

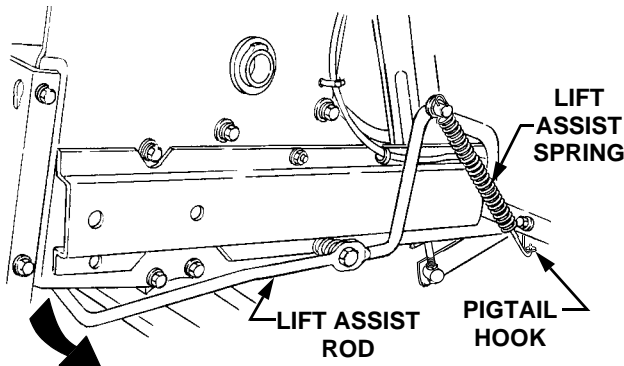

Figure 55

- Install the lower hook of the lift assist spring into the hole in the right rear deck bracket (See Figure 56).

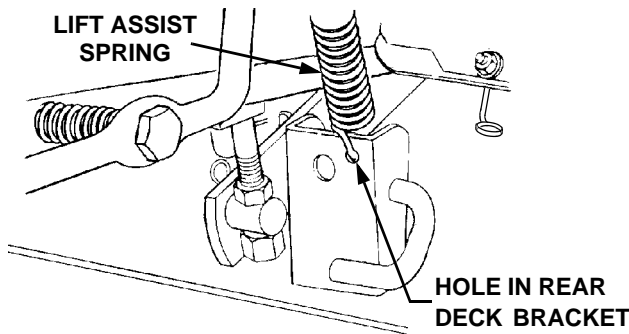

Figure 56

- Tension the spring by pushing downward and then inward on the rear of the lift assist rod, so that the flange at the rearward end of the rod is inside the tractor frame (See Figure 57).

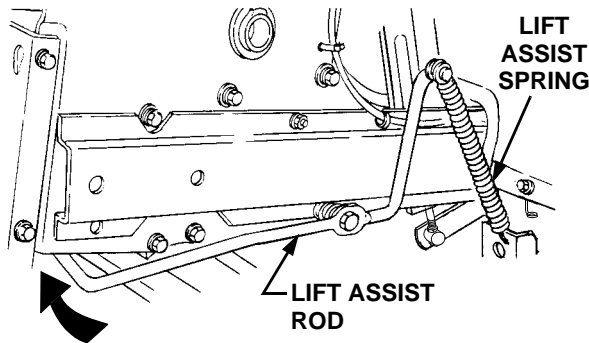

Figure 57

WARNING

The deck idler arm lever is spring loaded. Release it slowly.

- Disengage the deck idler arm lever from its stop bracket and release the spring tension by rotating the lever out and rearward (Refer to Figure 58).

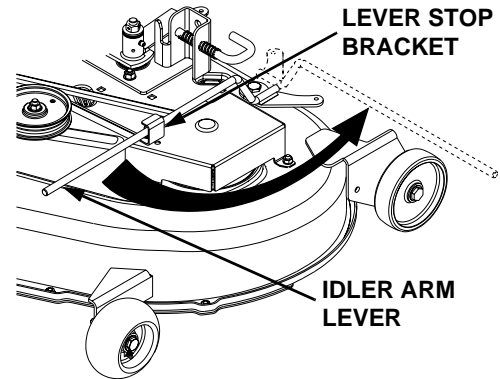

Figure 58

WARNING

The exhaust system is **HOT**. To avoid personal injury, allow the engine and exhaust system to cool before proceeding with the following PTO belt installation instructions.

- Pass the PTO belt upward inside the front of the tractor frame and install the forward end of the belt onto the PTO clutch pulley on the front of the engine. Ensure that the narrow side of the PTO belt engages the groove of the clutch pulley (Refer to Figure 59).

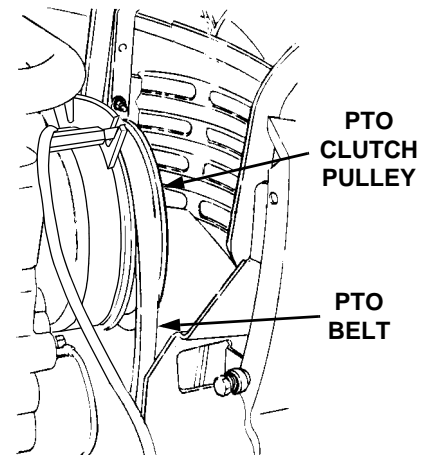

Figure 59

- Twist the two sides of the PTO belt 1/4 turn inward to engage the narrow sides of the belt into the grooves of the two tractor front-lower pulleys (Refer to Figure 60).

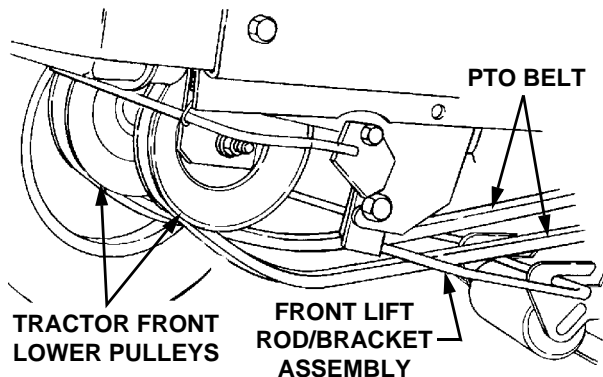

Figure 60

- From the front of the tractor, push the PTO belt through the front lift rod, then to the center of the deck. Ensure that the forward end of the belt remains positioned inside the front lower pulleys.
- Install the rearward end of the PTO belt on the upper pulley of the deck center double-pulley (Refer to Figure 61). Ensure that the narrow side of the belt engages the groove of the upper pulley.

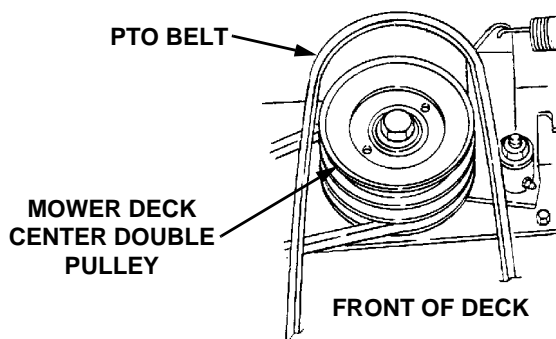

Figure 61

- While holding the belt in position, rotate and engage the deck idler arm lever into its stop bracket to provide tension on the PTO belt (Refer to Figure 62).

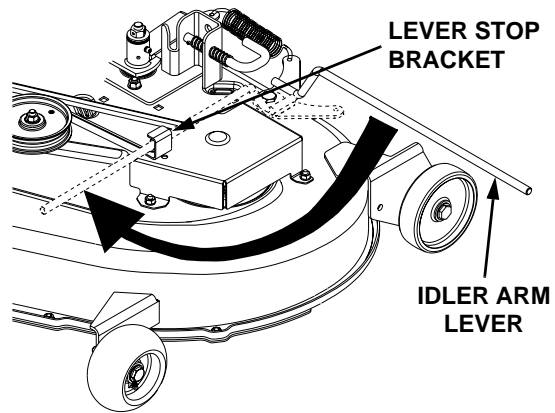

Figure 62

- Connect the spark plug wires if disconnected.

D. MAINTENANCE

CLEANING AND BLADE CARE



WARNING

Before performing any maintenance, place the PTO switch in the "OFF" position, engage the brake pedal lock, turn the ignition key to the "OFF" position and remove the key from the switch to avoid accidental starting and injury.



WARNING

When servicing the mower deck, be careful not to cut yourself on the sharpened blades.

Clean the underside of the mower deck at the end of the mowing season or when buildup of cut material on the underside is noticed. Also remove the belt covers and remove any accumulated grass clippings.

If using the mulching option, clean the underside of the deck frequently. A buildup of grass clippings will prevent proper mulching.

The cutting blades must be kept sharp at all times.



NOTE

Evenly sharpen the full length of the cutting edges of the blades so that the blades remain balanced and the same angle of sharpness is

maintained. If the cutting edge of a blade has been sharpened to within 5/8 inch of the wind wing radius (see Figure 63), it is recommended that new blades be installed. New blades are available at your authorized dealer.

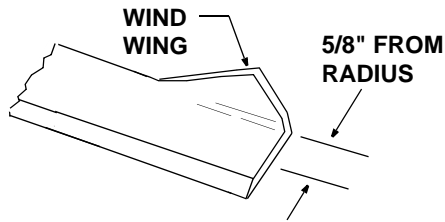

Figure 63

When removing the blades, use a 1-1/8 inch wrench to hold the hex head of the spindle bolt when loosening the hex nut securing the blade. A block of wood may be placed between the deck housing and the cutting edge of the blade to assist in removal of the hex nut securing the blade (Refer to Figure 64).

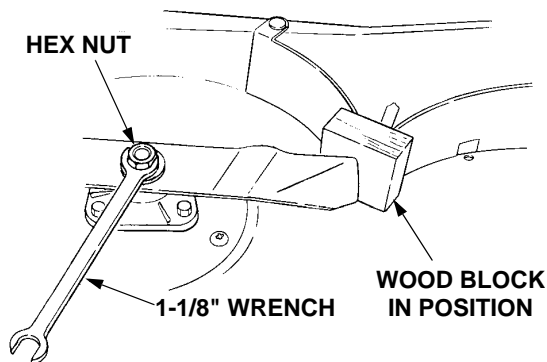

Figure 64

After replacing the blades, apply grease the exposed threads at the bottom of the spindle bolts to prevent rust buildup.

When replacing the blades, be sure they are installed so that the wind wings are pointing upward toward the top of the deck housing. Tighten the nuts to 90 to 110 ft-lbs. (122 to 149 N-m).

LUBRICATION

NOTE: We do not recommend the use of a pressure washer or garden hose to clean your unit. They may cause damage to electrical components, spindles, pulleys, bearings, or the engine. The use of water will result in shortened life and reduce serviceability.

After every 10 hours of operation and/or before putting the deck into winter storage, lubricate the spindle assemblies and the spindle belt idler arm with 251H EP grease or an equivalent No. 2 multipurpose lithium grease. Excess grease will be expelled from the inverted upper seals of the spindle assemblies. Listen for the muffled crackling noise of grease being expelled through the seal to indicate the spindle assembly is fully greased. Refer to Figure 65.

Every 50 hours, or twice yearly, lubricate the double pulley with 251H EP grease or an equivalent No. 2 multipurpose lithium grease. Do not over lubricate. Refer to Figure 65.

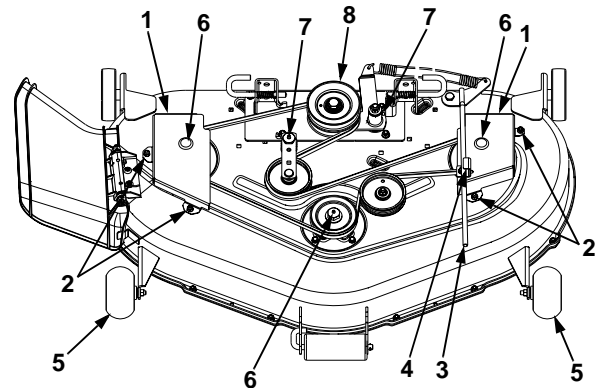

- | | |
|----------------------------|-------------------------------------|
| 1. Spindle Belt Cover | 6. Spindle Assembly Grease Fittings |
| 2. Hex Nuts & Lock Washers | 7. Idler Arm Grease Fitting |
| 3. Idler Arm Lever | 8. Double Pulley |
| 4. Stop Bracket | |
| 5. Front Ball Wheels | |

Figure 65

SPINDLE DRIVE BELT REPLACEMENT

In order to replace the spindle drive belt, refer to Figures 65 and 66 and proceed as follows:

1. Disengage the idler arm lever from its stop bracket and rotate the lever to the outside of the deck to release the spring tension.
2. Remove the hex nuts and lock washers that secure the spindle belt covers to the deck.
3. Remove the spindle belt covers to expose the belt.
4. Pull the movable flat idler pulley away from the backside of the belt and slip the belt under the idler pulley.
5. Remove the old drive belt from the spindle pulleys and flat idler pulley.

6. Carefully slip the new belt under the movable flat idler pulley
7. Route the new belt around the spindle pulleys, the fixed idler pulley, and the bottom pulley of the center double pulley. Refer to Figure 66 for the proper routing of the belt.
8. Pull the moveable flat idler pulley toward the left side of the deck and position the backside of the belt in the pulley. Release the pulley to tension the belt.
9. Reinstall the spindle belt covers.
10. Engage the idler arm lever into its stop bracket.

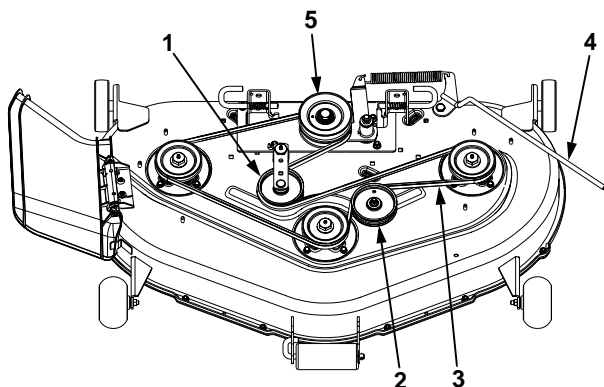

1. Moveable Flat Idler Pulley 4. Idler Arm Lever
 2. Fixed Flat Idler Pulley 5. Center Double Pulley
 3. Spindle Drive Belt

Figure 66

D. INSTALLATION OF MULCHING PLUG



WARNING

Before installing the mulching plug, place the PTO switch in the "OFF" position, engage the brake pedal lock, turn the ignition key to the "OFF" position.

1. If the mower deck has been used, clean any buildup of grass clippings from the chute opening of the deck housing.
2. Lift and hold the chute deflector in the upward position (Refer to Figure 67).
3. Position the mulching plug so that the retaining lip on the backside of the plug partially interlocks with the lower edge of the deck chute opening; then rotate the top of the plug upward so that the hooks engage the deflector hinge rod (See Figure 67).
4. Push the mulching plug fully downward and lower the chute deflector.
5. To remove the mulching plug, raise the chute deflector and lift the mulching plug upward, then outward to disengage from the deck. Lower the chute deflector.

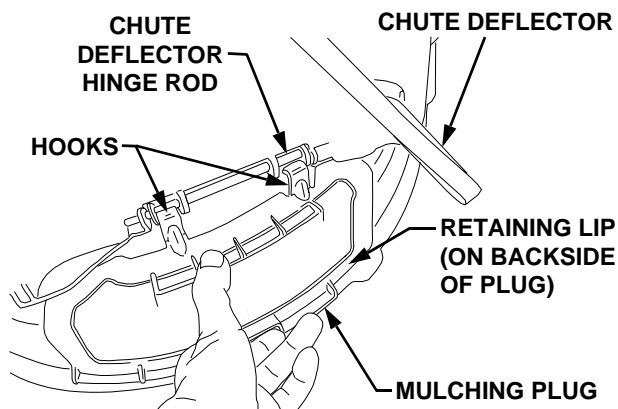
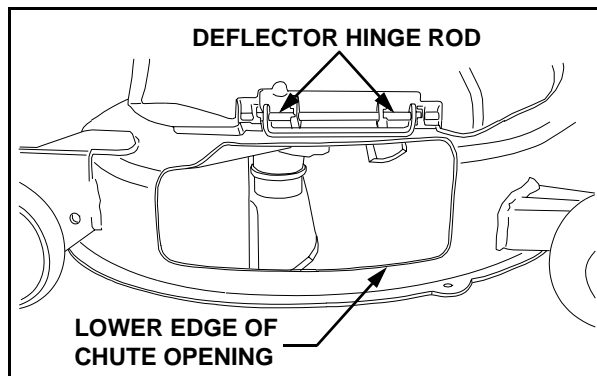

Figure 67

SECTION VI. OFF-SEASON STORAGE

If the machine is to be inoperative for a period longer than 30 days, the following procedures are recommended:



WARNING

Never store the tractor with fuel in the tank indoors or in poorly ventilated enclosures, where fuel fumes may reach an open flame, spark or pilot light as on a furnace, water heater, clothes dryer, etc.



CAUTION

Fuel left in the fuel tank during warm weather deteriorates and will cause serious starting problems.

To prevent gum deposits from forming inside the engine's carburetor and causing possible malfunction of the engine, the fuel system must be either completely emptied, or the gasoline must be treated with a stabilizer to prevent deterioration.

1. If using a fuel stabilizer:
 - a. Read the product manufacturer's instructions and recommendations.
 - b. Add to clean, fresh gasoline the correct amount of stabilizer for the capacity of the fuel system.
 - c. Fill the fuel tank with treated fuel and run the engine for 2-3 minutes to get stabilized fuel into the carburetor.

2. If emptying the fuel system:



WARNING

Do not drain fuel when the engine is hot. Allow the engine adequate time to cool. Drain fuel into an approved container outdoors, away from open flame.

- a. Drain any large volume of fuel from the tank by disconnecting the fuel line from the in-line fuel filter near the engine.
 - b. Reconnect the fuel line and run the engine until it starts to falter, then use the choke to keep the engine running until all fuel in the carburetor has been exhausted.
 - c. Again disconnect the fuel line and drain any remaining gasoline from the system.
3. Remove the spark plug and pour one (1) ounce of engine oil through the spark plug hole into the cylinder. Crank the engine several times to distribute the oil. Replace the spark plug.
 4. Clean the engine and the entire tractor thoroughly.

NOTE: We do not recommend the use of a pressure washer or garden hose to clean your unit. They may cause damage to electrical components; spindles; pulleys; bearings; or the engine. The use of water will result in shortened life and reduce serviceability.
 5. Lubricate all lubrication points.
 6. Follow the battery storage instructions on page 30.
 7. Protect the tires and seat from sunlight. Regularly check the tires to maintain proper inflation.

SECTION VII. MOWING

MOWING



WARNING

To avoid possible injury, do not allow anyone in the area opposite the discharge chute while mowing. Although the area has been supposedly cleared of foreign objects, small objects may be picked up and discharged by the mower.



WARNING

Never direct the discharge of material toward bystanders or allow anyone near the machine while in operation.

For best results it is recommended that the first two laps should be cut with the discharge thrown towards the center. After the first two laps, reverse the direction to throw the discharge to the outside for the balance of cutting. This will give a better appearance to the lawn.

Do not cut the grass too short, as the mower will tend to scalp the grass. Short grass invites weed growth and yellows quickly in dry weather.

Mowing should be done with the engine at full throttle. Do not mow at high ground speed.

During certain times of the year and under some conditions, the mower may leave streaks of uncut grass.

Streaking may occur when attempting to mow heavy weeds and tall grass. Under these conditions it may be necessary to go back over the cut area a second time to get a clean cut.

The following practices will help eliminate streaking:

1. Mow the area more often so the grass doesn't get too tall and heavy.
2. Operate the tractor at full throttle and slower forward speeds.
3. Keep the blades sharp and replace the blades when worn.
4. Follow the mowing pattern shown in Figure 68.

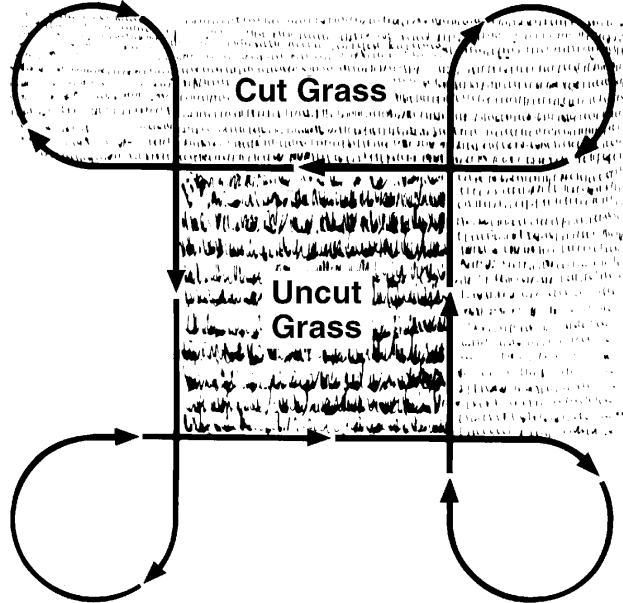

Figure 68

MOWING WITH MULCHING OPTION

1. **Do not cut wet grass.** For effective mulching do not cut wet grass. Wet grass sticks to the underside of the deck prevention proper mulching and dispersal of grass clippings.
2. **Cut no more than 1/3 the length of the grass.** When mulching long grass, it may be necessary to mow twice, lowering the deck another 1/3 of the length for the second cut, and perhaps cutting in a different pattern. Overlap the cut on each pass to help clean up any heavy clippings left on the lawn.
3. **Use a slow ground speed.** Adjust ground speed so clippings can be evenly dispersed into the lawn. When cutting heavy grass, it may be necessary to use a slower ground speed in order to get a well mulched cut.
4. **Always operate the tractor at full throttle.** To obtain the best cut and do the most effective job of mulching, the engine should be run at full throttle.
5. **Clean underside of deck.** Be certain to clean the underside of the deck often to avoid a buildup of grass clippings, which will prevent proper mulching.

OPTIONAL EQUIPMENT AND ACCESSORIES

When you purchased your tractor, you probably had it completely equipped for your particular needs at the time. However, later you may wish to obtain optional equipment or accessories. These items and other allied equipment can be purchased from, and installed by, your authorized *Cub Cadet* dealer.

The tractor is used for so many different types of work, and because it is called on to operate under so many different conditions, a variety of equipment is available to adapt it to the requirements of the user. **Refer to the attachment guide for a complete description of equipment and required components that can be utilized with your tractor.**

MAINTENANCE CHART

Operation to be performed	Before each use	10 hours or once a month	30 hours or three times a season	50 hours or twice a season	100 hours or yearly	Before storage
Clean grille, engine air inlet screen, dash intake screen and side panel screens		More often under dirty conditions X				
Check engine oil level	X					
Fill fuel tank	X					
Change engine oil & oil filter					More often under dirty conditions X	
Check transmission oil level	X					
Replace transmission oil filter		After first 10 hours X		After first 50 hours X	Every 100 hours thereafter X	
Clean & re-oil foam air precleaner		X				
Check battery terminals and case		X				
Grease front axle pivot bolt		X				
Grease steering knuckles		X				
Retorque rear wheel lug nuts		After first 10 hours X				
Clean cooling fins & external surfaces			X			
Replace air cleaner paper cartridge					More often under dirty conditions	
Check spark plugs					X	X
Grease steering arm housing			X			X
Grease front wheel bearings			X			X
Drain fuel						X
Pivot bar adjustment bolts				X		
Grease deck spindles and spindle belt idler arm		X				X
Lube deck double pulley				X		X
Deck front gauge wheels				X		X
Lubricate all foot and lift control pivot points		X				X

NOTE

Maintenance information for optional equipment may be found in the manual which is included with that specific piece of equipment.

TROUBLE SHOOTING

Possible Cause

Possible Remedy

HARD TO START

No gasoline in fuel tank or carburetor	Fill the tank with gasoline. Check the fuel line, carburetor and fuel filter.
Fuel line or carburetor clogged.....	Clean the fuel line and carburetor with a commercial carburetor cleaner.
Fuel filter plugged.....	Replace.
Water in gasoline.....	Drain the fuel tank and carburetor. Use new fuel and dry the spark plugs.
Choked improperly. Flooded engine	Follow the starting instructions.
Defective ignition or loose wiring.....	Check the wiring, spark plugs or fuse.
Defective battery	Check and service. Refer to “BATTERY.”
Spark plug dirty or improper gap	Clean, adjust the gap to .030-inch or replace the plug.

ENGINE OPERATES IRREGULARLY OR KNOCKS

Engine incorrectly timed	*
Spark plug dirty; wrong gap or wrong type.....	Clean, reset the gap or replace.
Poor or weak spark	Check the spark plugs and wiring.
Carburetor setting incorrect.....	*
Poor grade fuel or water in fuel	Drain and use a good grade of clean fuel.
Engine overheating	Refer to “MAINTENANCE.”
Engine valves at fault	*
Engine smokes.....	*
Oil level rises due to gasoline in crankcase	*
Air filter becomes oil and fuel soaked.....	*
Engine leaks oil	*
Misfiring.....	*
Other engine problems.....	*
Excessive oil in air cleaner	Be sure that oil dipstick is fully seated and all excess oil is squeezed out of the pre-cleaner foam element.

PTO CLUTCH WILL NOT ENGAGE

Low or zero voltage	Check battery. Charge or replace. Check charging system. Check for worn or broken wiring or connections. Check clutch coil resistance. Check switch.
Rotor/armature air gap too large	Rotor/armature worn. Replace PTO clutch.

* See your authorized dealer.

TROUBLE SHOOTING

Possible Cause

Possible Remedy

LACK OF POWER

Air cleaner clogged	Service the air cleaner element. Refer to “ MAINTENANCE. ”
Engine overload	Reduce the load.
Engine overheated.....	Make sure the air intake screen, shrouding, engine fins, side panels, dash intake screen and grille are free of accumulated dirt and debris. Refer to “ MAINTENANCE. ”
Fuel tank air vent clogged.....	Remove obstruction from the vent in the fuel tank cap.
Air leakage between carburetor and engine	Remove air cleaner. Tighten the carburetor and manifold mounting nuts. Replace any damaged parts as indicated in “ MAINTENANCE. ”
Incorrect timing or faulty ignition	*
Brake dragging.....	Adjust the brake. Refer to “ ADJUSTMENTS. ”
Insufficient cooling air — dirt or debris clogging the: air intake screen • shrouds • cooling fins • side panels • dash intake screen • or grille	Keep the air intake area, side panels, grille, dash intake screen and cooling fins clean; refer to “ MAINTENANCE. ”
Oil level incorrect	Engine oil level must not be over the “FULL” mark or below the “LOW” mark on dipstick. Refer to “ MAINTENANCE. ”

* See your authorized dealer.

LUBRICATION TABLE

Point of Lubrication	Check at Hours	Change at Hours	Capacity	Anticipated Air Temperature		
				Above +32°F	0°F and Above	32°F or Below
Engine crankcase	Check before each use	100	Approx. 4 pints	Cub Cadet Engine Oil SAE 10W30	Cub Cadet Engine Oil SAE 10W30	Cub Cadet Engine Oil SAE 5W20 SAE 5W30
Hydro drive unit and transmission case with filter	Check before each use	Add as needed	Approx. 6 qts	Cub Cadet Drive System Fluid Plus NOTE: <i>Cub Cadet</i> Drive System Fluid Plus is specially formulated for this application. If any other oil is used <i>Cub Cadet</i> will not be responsible for substandard performance. Failures due to use of improper fluid are not covered by warranty. For maximum protection, use <i>Cub Cadet</i> Drive System Fluid.Plus		
Steering knuckles and front axle pivot bolt	10			Use 251H EP grease or equivalent No. 2 multi-purpose lithium grease and apply two strokes (minimum) or sufficient grease to flush out old grease and dirt.		
Front wheel bearings	30			Two strokes (minimum) of the lubricator using 251H EP grease or equivalent No. 2 multi-purpose lithium grease.		
Steering arm housing	30			Two strokes (minimum) of the lubricator using 251H EP grease or equivalent No. 2 multi-purpose lithium grease.		
Deck spindles	10			Two strokes (minimum) of the lubricator using 251H EP grease or equivalent No. 2 multi-purpose lithium grease.		
Spindle belt idler arm	10			Two strokes (minimum) of the lubricator using 251H EP grease or equivalent No. 2 multi-purpose lithium grease.		
Deck Double Pulley	50			Use 251H EP grease or equivalent No. 2 multi-purpose lithium grease. Do not over lubricate.		
Deck front gauge wheels	50			Use 251H EP grease or equivalent No. 2 multi-purpose lithium grease.		
Foot and lift control pivot points	10			Use a liberal amount of high grade lubricating oil.		

LUBRICATION GUIDE



WARNING

The service life and reliability of any machine depends upon the care it is given. Proper lubrication is a very important part of that care. This lubrication schedule reflects the minimal requirements to maintain the equipment. More frequent inspections and maintenance is preferable.

NOTE: *We do not recommend the use of a pressure washer or garden hose to clean your unit. They may cause damage to electrical components; spindles; pulleys; bearings; or the engine. The use of water will result in shortened life and reduce serviceability.*

Using the lubrication illustration as a guide, make certain that all lubrication fittings are installed and functioning.

Be sure all fittings are free from dirt and paint so the lubricant is certain to enter the bearing.

Using a pressure lubricating gun, always force the lubricant through the full length of each bearing until it emerges at the end, carrying with it the worn lubricant and any dirt that may have entered the bearing.

Miscellaneous working parts not provided with lubrication fittings should be oiled regularly with a good grade of lubricating oil.

Always lubricate the tractor thoroughly before taking it to a remote location for a prolonged period of time.

Lubricant is cheap. Use plenty of it. Worn parts can be expensive to replace.

Keep your supply of lubricating oil and grease stored in clean containers, and covered to protect from dust and dirt.

Keep the lubricating gun nozzle clean and wipe dirt from the grease fittings before lubricating.

The symbols in the illustrations indicate the method of application and the hourly intervals to apply the lubricant.



Use a pressure lubricating gun and apply 251H EP grease (or equivalent No. 2 multi-purpose lithium grease) sufficient to flush out the old grease and dirt. Lubricate at the hourly intervals indicated on the symbols.



Dipstick, use to check engine and transmission oil before each use.

LUBRICATION GUIDE

—Before Each Use

1. Engine filler cap and dipstick Check the oil (with the engine stopped) and add sufficient new oil to bring it to the “**FULL**” mark on the dipstick. Do not overfill. Do not operate the engine if the oil level is below the “**LOW**” mark on the dipstick.
2. Transmission oil level and fill port Check the oil with the engine stopped. Keep the lubricant up to the “**FULL**” mark on the dipstick.
NOTE: The transmission oil level and fill port services the following:
 1. Rear axle
 2. Hydrostatic transmission

—After Every 10 Hours of Operation

3. Steering knuckles (2) (both sides) Use 251H EP grease or an equivalent No. 2 multi-purpose lithium grease and apply sufficient grease to flush out old grease and dirt.
4. Transmission oil filter **NOTE:** After the first 10 hours only, remove the transmission oil filter and replace with a new filter. Refer to “**MAINTENANCE.**” Change the transmission oil filter after 50 hours and every 100 hours of operation thereafter.
5. Front axle pivot bolt Use 251H EP grease or an equivalent No. 2 multi-purpose lithium grease and apply sufficient grease to flush out old grease and dirt.
6. Foot and lift control pivot points Use a liberal amount of high grade lubricating oil.
7. Deck spindles Use 251H EP grease or an equivalent No. 2 multi-purpose lithium grease and apply 2 strokes (minimum) or sufficient grease to flush out old grease and dirt.
8. Spindle belt idler arm Use 251H EP grease or an equivalent No. 2 multi-purpose lithium grease and apply 2 strokes (minimum) or sufficient grease to flush out old grease and dirt.

—After Every 30 Hours of Operation

9. Front wheel bearings Two or three strokes minimum of the lubricator using 251H EP grease or an equivalent No. 2 multi-purpose lithium grease.
10. Steering arm housing Every 30 hours or three times a season, use 251H EP grease or an equivalent No. 2 multi-purpose lithium grease.

—After Every 50 Hours of Operation

11. Transmission oil filter **NOTE:** After the first 50 hours only, remove the transmission oil filter and replace with a new filter. Refer to “**MAINTENANCE.**” Change the transmission oil filter every 100 hours of operation thereafter.
12. Deck front gauge wheels Use 251H EP grease or an equivalent No. 2 multi-purpose lithium grease and apply sufficient grease to flush out old grease and dirt
13. Deck double pulley Use 251H EP grease or an equivalent No. 2 multi-purpose lithium grease and apply sufficient grease to maintain lubrication.

—After Every 100 Hours of Operation

14. Transmission oil filter Change the transmission oil filter and replace with a new filter. Refer to “**MAINTENANCE.**”
15. Engine oil drain valve and oil filter While the engine oil is warm, remove the drain cap and oil filter, and drain all of the oil from the crankcase. Replace the drain cap. Refer to **MAINTENANCE—“FILLING THE CRANKCASE”** and “**OIL FILTER**” for proper oil filling procedure. Refer to “**LUBRICATION TABLE**” for the proper quantity and viscosity to use.



Lubrication information for optional equipment may be found in the manual which is included with the specific piece of optional equipment.

SLOPE GAUGE

(Keep this sheet in a safe place for future reference.)

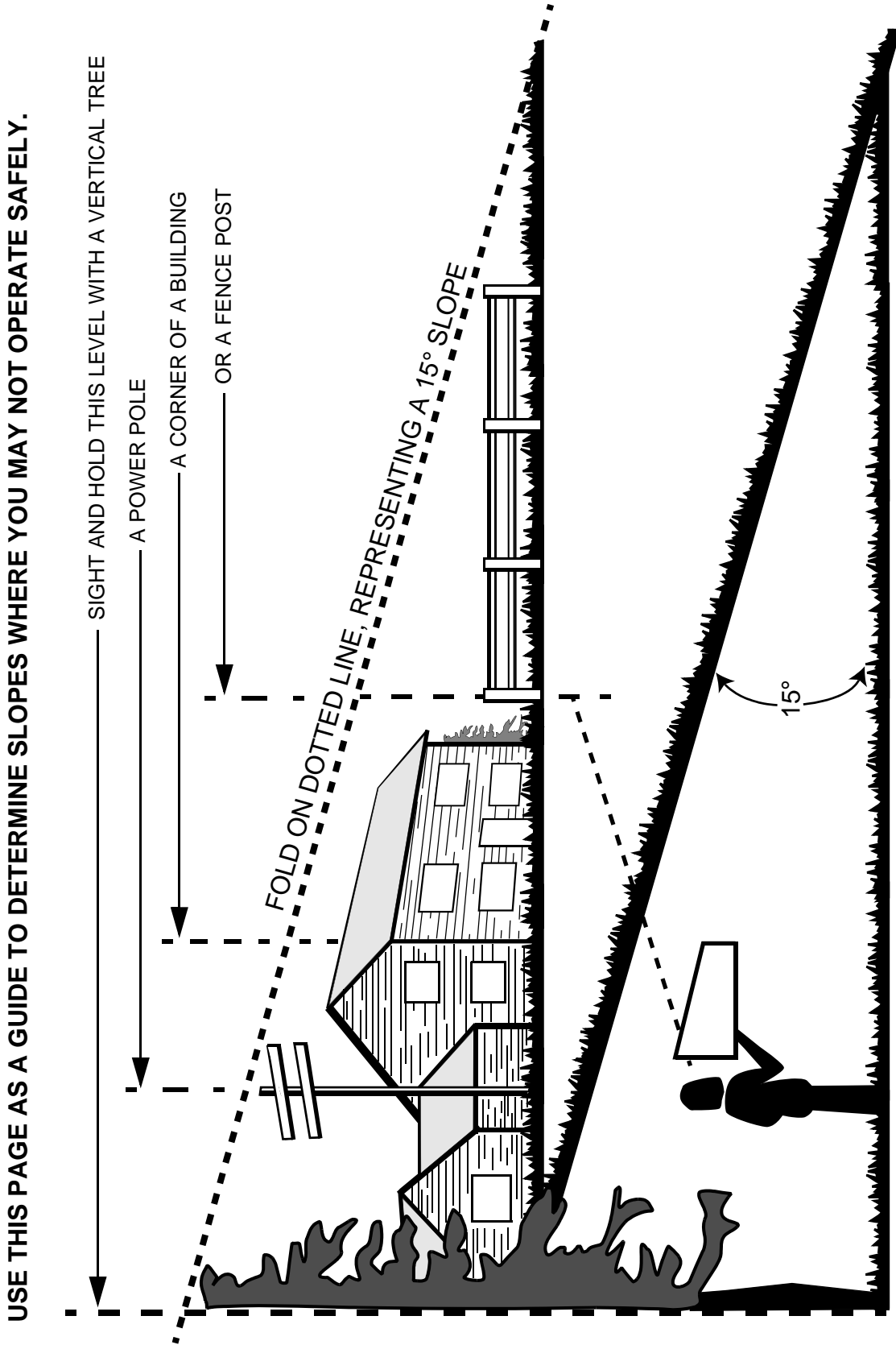

Do not mow on inclines with a slope in excess of 15 degrees (a rise of approximately 2-1/2 feet every 10 feet). A riding mower could overturn and cause serious injury. If operating a walk-behind mower on such a slope, it is extremely difficult to maintain your footing and you could slip, resulting in serious injury. Operate RIDING mowers up and down slopes, never across the face of slopes. Operate WALK-BEHIND mowers across the face of slopes, never up and down slopes.

SPECIFICATIONS

	GT 2186
CAPACITIES	
Fuel Tank	2-1/8 gallons
Crankcase (approximately)	4 pints
Transmission Case (approximately)	6 qts.
HYDROSTATIC DRIVE	
Speed: Forward.....	0 to 6 mph
Reverse	0 to 3 mph
ENGINE	
Make and Model	Kohler Command
Horsepower	20 HP
Cylinders	2
Bore	3.03 in.
Stroke	2.64 in.
Displacement (cubic inches)	38.1
Engine Speed (governed)	
Low Speed	1200 RPM
High Speed (no load)	3600 RPM ± 75
Ignition	Battery
Spark Plug Gap (Cub Cadet No. 759-3336)030 in.
ELECTRICAL SYSTEM	
System Voltage	12 volt neg. ground
Battery	725-1706
Alternator	15 amp regulated
Fuse (auto type)	25 amp
Head Lamp Bulb	725-0963
BRAKES	Internal expanding
TIRE SIZES	
Front	16 x 6.5-8
Rear	23 x 9.5-12
DIMENSIONS	
Tread:	
Front with 16 x 6.5-8 tires	31.5 in.
Rear with 23 x 9.5-12 tires	30.25 in.
Wheelbase	47.00 in.
Length, over all	72.00 in.
Width, over all (w/ mower deck - chute up)	49.00 in.
Height, over all (to top of steering wheel)	42.00 in.
Ground Clearance	6.00 in.
Turning Radius	28.0 in.

Specifications are subject to change without notice.

CUB CADET CORPORATION MANUFACTURER'S ONE YEAR LIMITED WARRANTY (COMMERCIAL USE)

The limited warranty set forth below is given by CUB CADET LLC ("CUB CADET") with respect to new merchandise purchased and used in the United States, its possessions and territories.

CUB CADET warrants this product against defects in material and workmanship for a period of one (1) year for commercial users, commencing on the date of original purchase and will, at its option, repair or replace, free of charge, any part found to be defective in material or workmanship. This limited warranty shall only apply if this product has been operated and maintained in accordance with the Operator's Manual furnished with the product, and has not been subject to misuse, abuse, neglect, accident, improper maintenance, alteration, vandalism, theft, fire, water or damage because of other peril or natural disaster. Damage resulting from the installation or use of any part, accessory or attachment not approved by Cub Cadet for use with the product(s) covered by this manual will void your warranty as to any resulting damage.

Batteries and belts are subject to separate terms as follows:

- a. Batteries have a one-year prorated limited warranty with 100% replacement during the first three months. After three months, the battery replacement credit is based on the months remaining in the twelve (12) month period dating back to the original date of sale. Any replacement battery will be warranted only for the remainder of the original warranty period.
- b. All belts are covered by a one (1) year limited warranty against defects in material and workmanship.

HOW TO OBTAIN SERVICE: Warranty service is available, WITH PROOF OF PURCHASE, THROUGH YOUR LOCAL AUTHORIZED CUB CADET DEALER. To locate the dealer in your area, please check for a listing in the Yellow Pages or contact Cub Cadet LLC at P.O. Box 361131, Cleveland, Ohio 44136-0019, or call 1-877-282-8684, or log on to our Web site at www.cubcadet.com.

This limited warranty does not provide coverage in the following cases:

- a. Routine maintenance items such as lubricants, filters, tune-ups, or adjustments such as brake adjustments, or clutch adjustments; and normal deterioration of the exterior finish due to use or exposure.
- b. Normal wear parts or components, including batteries, belts, seats and tires.

- c. CUB CADET does not extend any warranty for products sold or exported outside of the United States of America, its possessions and territories, except those sold through CUB CADET'S authorized channels of export distribution.
- d. Replacement parts that are not genuine Cub Cadet parts.
- e. Service completed by someone other than an authorized service dealer.

No implied warranty, including any implied warranty of merchantability or fitness for a particular purpose, applies after the applicable period of express written warranty above. No other express warranty or guaranty, whether written or oral, except as mentioned above, given by any person or entity, including the dealer, with respect to any product shall bind CUB CADET. During the period of the Warranty, the exclusive remedy is repair or replacement of the product as set forth above. (Some states do not allow limitations on how long an implied warranty lasts, so the above limitation may not apply to you.)

The provisions as set forth in this Warranty provide the sole and exclusive remedy arising from the sale. CUB CADET shall not be liable for incidental or consequential loss or damages including, without limitation, to any claim for loss of profits, loss of savings or revenue, loss of the use of the equipment or any associated equipment, facilities or service, downtime, the claims or costs of third parties including customers, and injury to property, and further including expenses incurred for substitute or replacement lawn care services, for transportation or for related expenses, or for rental expenses to temporarily replace a warranted product. (Some states do not allow the exclusion or limitation of incidental or consequential damages, so the above exclusion may not apply to you.)

In no event shall recovery of any kind be greater than the amount of the purchase price of the product sold. Alteration of the safety features of the product shall void this Warranty. You assume the risk and liability for loss, damage, or injury to you and your property and/or to others and their property arising out of the use or misuse or inability to use the product.

This limited warranty shall not extend to anyone other than the original purchaser or original lessee.

How State Law Relates to this Warranty: This limited warranty gives you specific legal rights, and you may also have other rights which vary from state to state.

**IMPORTANT: Owner must present Original Proof of Purchase to obtain warranty coverage.
Cub Cadet LLC, P.O. BOX 361131 CLEVELAND, OHIO 44136-0019; Phone: 1-877-282-8684**

CUB CADET CORPORATION MANUFACTURER'S LIMITED WARRANTY (RESIDENTIAL USE)

The limited warranty set forth below is given by CUB CADET CORPORATION ("CUB CADET") with respect to new merchandise purchased and used in the United States, its possessions and territories.

CUB CADET warrants this product against defects in material and workmanship for a period of two (2) years for residential users, (one (1) year for commercial users), commencing on the date of original purchase and will, at its option, repair or replace, free of charge, any part found to be defective in material or workmanship. This limited warranty shall only apply if this product has been operated and maintained in accordance with the Operator's Manual furnished with the product, and has not been subject to misuse, abuse, neglect, accident, improper maintenance, alteration, vandalism, theft, fire, water or damage because of other peril or natural disaster. Damage resulting from installation or use of any part, accessory, or attachment not approved by Cub Cadet for use with the product(s) covered by this manual will void your warranty as to any resulting damage.

Batteries and belts are subject to separate terms as follows:

- a. Batteries have a one-year prorated limited warranty with 100% replacement during the first three months. After three months, the battery replacement credit is based on the months remaining in the twelve (12) month period dating back to the original date of sale. Any replacement battery will be warranted only for the remainder of the original warranty period.
- b. All belts are covered by a one (1) year limited warranty against defects in material and workmanship.

3 Year Limited Warranty - PTO Clutch

CUB CADET warrants the power take off (PTO) clutch and mounting hardware against defects in material and workmanship for a period of three (3) years for Series 2000 products for residential users, commencing on the date of original purchase or lease and CUB CADET will, at its option, repair or replace, free of charge, any PTO clutch or mounting hardware found to be defective in material or workmanship provided this product has been operated and maintained as set forth above.

5 Year/500 Hour Limited Warranty

CUB CADET warrants the frame, front cast iron pivot axle and drive shaft on Series 2000 and 3000 models against defects in material and workmanship for a period of five (5) years or 500 hours, whichever occurs first, for residential users, commencing on the date of original purchase or lease and CUB CADET will, at its option, repair or replace, free of charge, any part found to be defective in material or workmanship provided this product has been operated and maintained as set forth above. In addition to any other reason set forth herein, CUB CADET may deny warranty coverage if the hour meter, or any part thereof, is altered, modified, disconnected or otherwise tampered with.

HOW TO OBTAIN SERVICE: Warranty service is available, **WITH PROOF OF PURCHASE**, THROUGH YOUR LOCAL AUTHORIZED CUB CADET DEALER. To locate the dealer in your area, please check for a listing in the Yellow Pages or contact Cub Cadet LLC at P.O. Box 361131, Cleveland, Ohio 44136-0019, or call 1-877-282-8684, or log on to our Web site at www.cubcadet.com.

This limited warranty does not provide coverage in the following cases:

- a. Routine maintenance items such as lubricants, filters, blade sharpening, tune-ups, brake adjustments, clutch adjustments, deck adjustments, and normal deterioration of the exterior finish due to use or exposure.
- b. CUB CADET does not extend any warranty for products sold or exported outside of the United States of America, its possessions and territories, except those sold through CUB CADET's authorized channels of export distribution.
- c. Replacement parts that are not genuine Cub Cadet parts.
- d. Service completed by someone other than an authorized service dealer.
- e. Transportation charges and service calls.

No implied warranty, including any implied warranty of merchantability or fitness for a particular purpose, applies after the applicable period of express written warranty above as to the parts as identified. No other express warranty, whether written or oral, except as mentioned above, given by any person or entity, including the dealer, with respect to any product, shall bind CUB CADET. During the period of the warranty, the exclusive remedy is repair or replacement of the product as set forth above.

The provisions as set forth in this Warranty provide the sole and exclusive remedy arising from the sales. CUB CADET shall not be liable for incidental or consequential loss or damages including, without limitation, expenses incurred for substitute or replacement lawn care services or for rental expenses to temporarily replace a warranted product.

Some states do not allow the exclusion or limitation of incidental or consequential damages, or limitations on how long an implied warranty lasts, so the above exclusions or limitations may not apply to you.

In no event shall recovery of any kind be greater than the amount of the purchase price of the product sold. **Alteration of the safety features of the product shall void this Warranty.** You assume the risk and liability for loss, damage, or injury to you and your property and/or to others and their property arising out of the use or misuse or inability to use the product.





This limited warranty shall not extend to anyone other than the original purchaser or to the person for whom it was purchased as a gift.

How State Law Relates to this Warranty: This limited warranty gives you specific legal rights, and you may also have other rights which vary from state to state.

IMPORTANT: Owner must present Original Proof of Purchase to obtain warranty coverage.

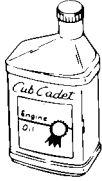
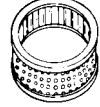
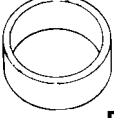
Cub Cadet LLC, P.O. BOX 361131 CLEVELAND, OHIO 44136-0019; Phone: 1-877-282-8684

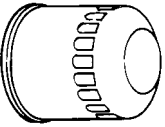
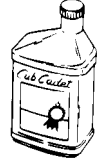
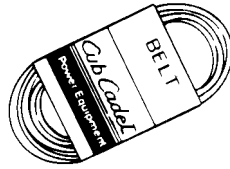
MAINTENANCE PARTS CHART

MODEL GT2186		SERIES 2000 20 HP KOHLER		
ENGINE OIL 	Engine Oil Requirements approx. . . 4 pints		Part No.	
	Cub Cadet engine oil Ambient temperature viscosity (Grade SG,SH,SJ or higher) Above +32°F SAE 10W30 Below +32°F SAE 5W20 or 5W30		737-3030A (10W30) 737-3049 (5W30)	
AIR FILTER   CARTRIDGE FOAM PRE-CLEANER	Air Filter Requirements		Part No.	
	Clean air filter per instructions in your Operator's Manual . . . under Maintenance - Air cleaner.		Cartridge KH-47-083-03 Foam Pre-cleaner KH-24-083-02	
ENGINE OIL FILTER 	Engine Oil Filter Requirements		Part No.	
	Change every 100 hours		KH-12-050-08	
SPARK PLUG 	Gap Requirements		Part No.	
	.030 inch gap		759-3336	
TRANSMISSION OIL FILTER 	Oil Filter Requirements		Part No.	
	Change every 100 hours		923-3014	
TRANSMISSION OIL 	Transmission Oil Requirements approx. . . 6 qts		Part No.	
	Check before each use <div style="display: flex; justify-content: space-around;"> 1 quart 1 gallon </div>		737-3120 737-3121	
BELTS 	Deck Blade Belt		Tractor to Deck Belt	
	Model	Part No.	Model	Part No.
	44" Deck	954-3039	44" Deck	754-04041
BLADES 	Original Equipment Blade			Part No.
	44" Mower Blade			759-3939 (3)
	Optional Blade			Part No.
	44" Hi-Lift Mower Blade			759-3949