



**READ AND UNDERSTAND ALL INSTRUCTION, WARNING, AND DANGER LABELS.**  
**PARA INSTRUCCIONES EN ESPAÑOL, REFIÉRESE AL MANUAL DEL OPERADOR.**



1

Fill fuel with gasoline purchased within the last 10 days and stored in a non-rusty/dirty can. Do not fill above the base of fuel tank neck. Check Oil level as instructed in your Engine Operator's Manual.

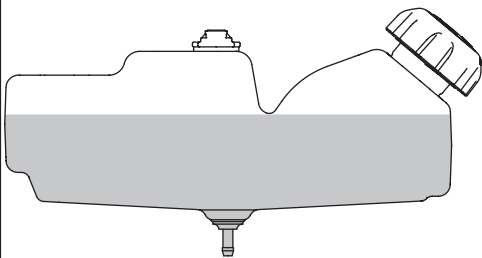

2

Check to make sure that both battery cables are connected.

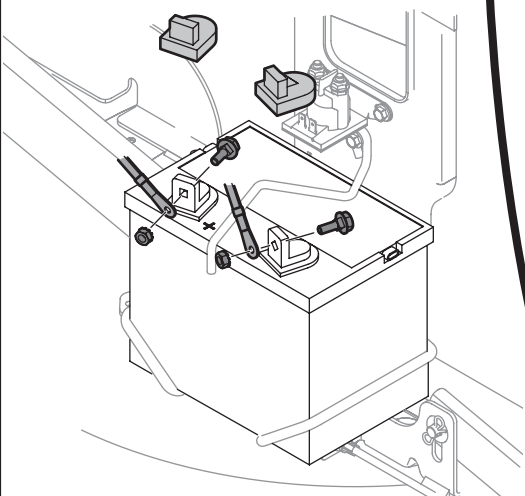

# FAST START GUIDE

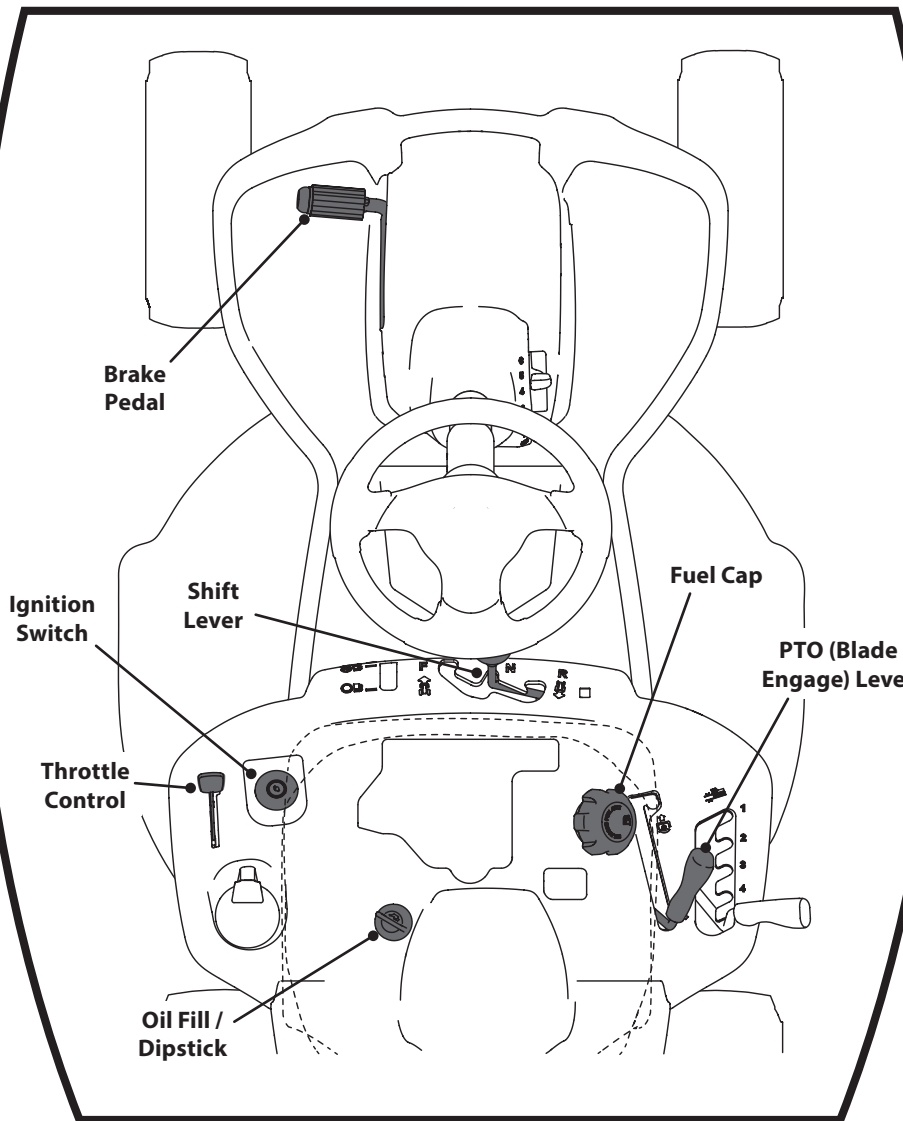

3

Make sure that the deck chute/mulch plug are properly installed and the safety switch on the deck surface is depressed.

**NOTE:** The engine will not start if the safety switch is not depressed.



4

Place PTO (Blade Engage) Lever in the OFF  position.

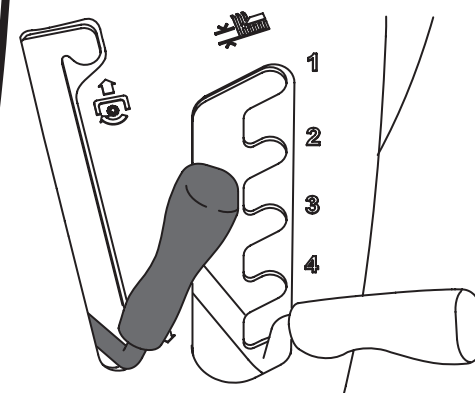

**IMPORTANT: READ OPERATOR'S MANUAL AND ENGINE MANUAL THOROUGHLY AND FOLLOW THE IMPORTANT SAFE OPERATION PRACTICES BEFORE OPERATING .**



**Need Help? Call 1-888-TO-HELP-U**



**READ AND UNDERSTAND ALL INSTRUCTION, WARNING, AND DANGER LABELS.**  
**PARA INSTRUCCIONES EN ESPAÑOL, REFIÉRESE AL MANUAL DEL OPERADOR.**



1

Place Shift Lever in N (NEUTRAL) position.

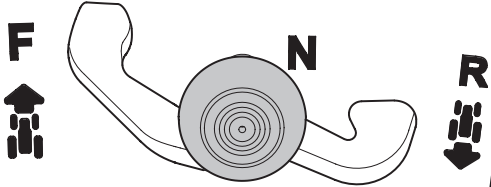

2

Fully depress the Brake Pedal and engage the Parking Brake.

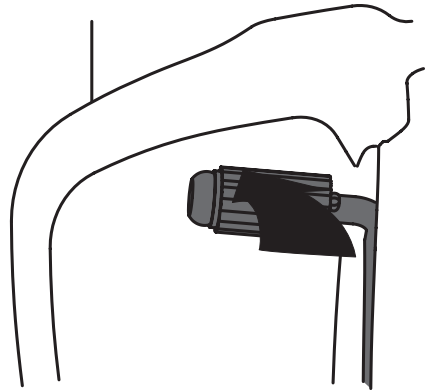

# FAST START GUIDE

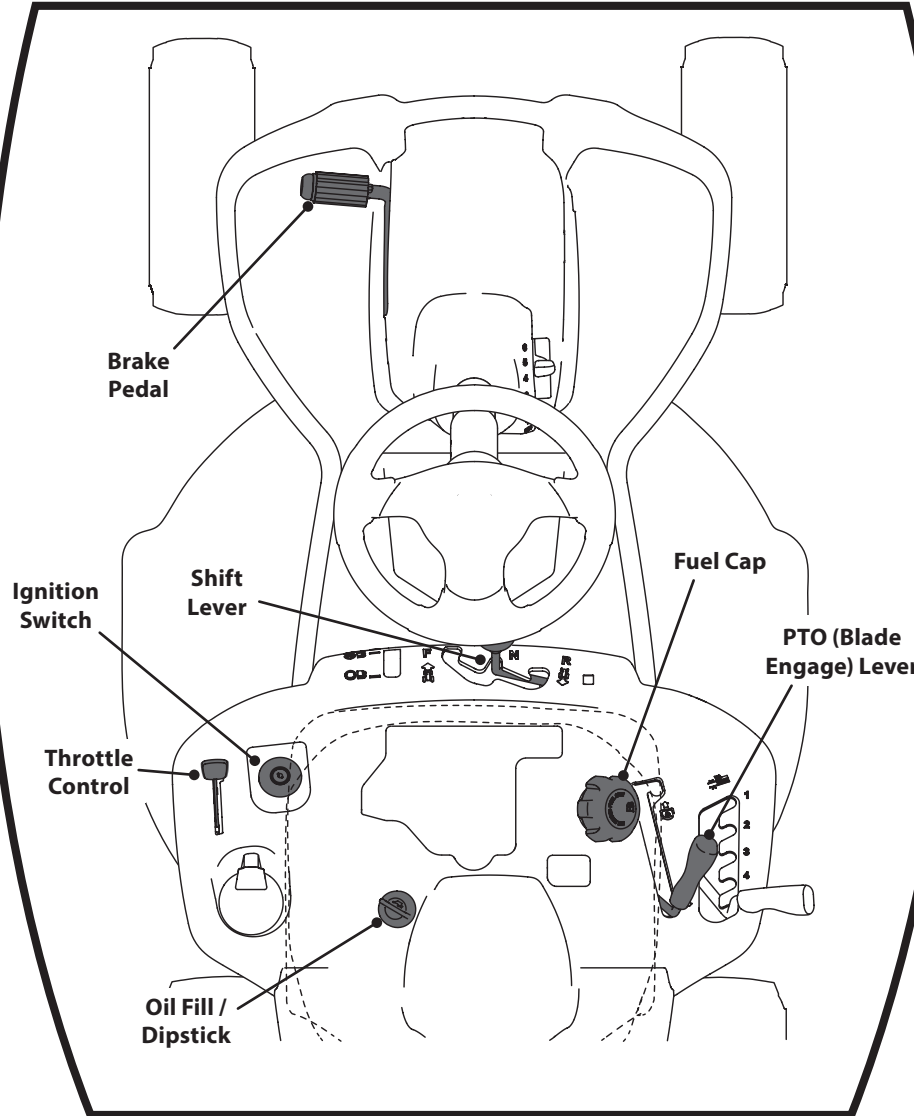

3

Move the throttle control into the CHOKE position.

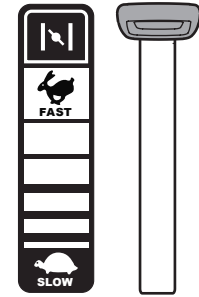

4

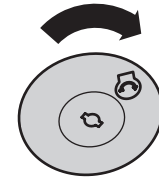

Insert the ignition key and turn it to the START position.  
 Release the ignition key after the engine starts.

5

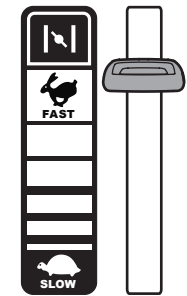

Move Throttle to Fast position.



**IMPORTANT: READ OPERATOR'S MANUAL AND ENGINE MANUAL THOROUGHLY AND FOLLOW THE IMPORTANT SAFE OPERATION PRACTICES BEFORE OPERATING .**



**Need Help? Call 1-888-TO-HELP-U**